

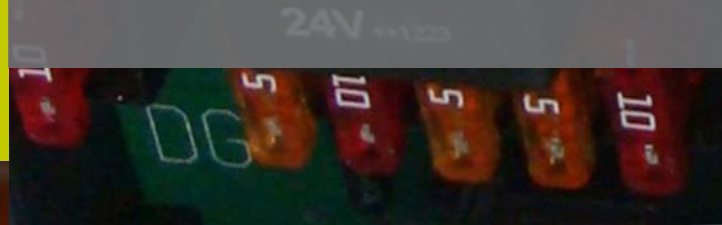

www.veigroup.com
info@veigroup.com



Installation Guide



Manual version
11113-00 ENGLISH



Content

1	Front-end Loader	3
	Load Sensors 1 & 2	3
	Weighing Zone Sensor	6
	Harnesses Wiring	10
	Power Supply	12
	Device Mounting	13
	Printer Mounting	17
	System Configuration Wizard	20
	Accuracy Control	22
2	Fork Lift truck	25
	Load Sensor 1	25
	Weighing Zone Sensor	26
	Harnesses Wiring	28
	Power Supply	29
	Device Mounting	29
	Printer Mounting	30
	System Configuration Wizard	31
	Accuracy Control	33
3	Telescopic Loader	36
	Load Sensors 1 & 2	36
	Weighing Zone Sensor	38
	Harnesses Wiring	40
	Power Supply	40
	Device Mounting	40
	Printer Mounting	41
	System Configuration Wizard	44
	Accuracy Control	46
4	Articulated Dump Truck	48
	Load Sensors 1 & 2	48
	Harnesses Wiring	49
	Power Supply	51
	Device Mounting	51
	Printer Mounting	52
	Weighing Button	54



Content

System Configuration Wizard	55
Accuracy Control	57

5 Material Handler 58

Load Sensor 1	58
Weighing Button	60
Power Supply	61
Device Mounting	61
Printer Mounting	62
System Configuration Wizard	65
Zero at Empty	67
Accuracy Control	69



Front-end Loader

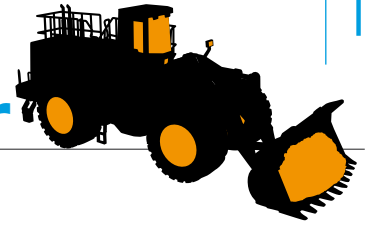

Load Sensors 1 & 2

Loader Installation Guide

Load Sensors 1 and 2 are installed along the hydraulic pipeline of the machine. Use the same cylinder for both sensors, it will be easier when running your cables towards the cabin, this is the only reason why; virtually one cylinder pressure or the other is the same and it makes no difference in which one you place your sensors. The installation must be done the closest possible to the cylinder avoiding to have valves in between the cylinder and the sensor.

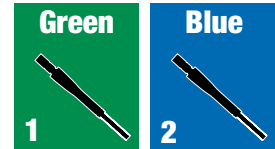

Avoid those positions where:

- a.** The sensor can be hit by rocks and other objects during working movements.
- b.** The cylinder is moving up and down, so is the sensor. If you have no other choice, then do it, carefully making sure the sensors are safe at any movement of the cylinder or use VEI micropipe (7) to bring the sensors in a protected area.

VEI has a selection of hydraulic fittings to cover all the installations. In case a machine model is not covered, please provide us with all the technical info for the adapter and we will try to include it into our database and manufacturing schedule.

Follow these simple steps to install the sensors. The example shows a flange fitting but it can be any other type of adapter.

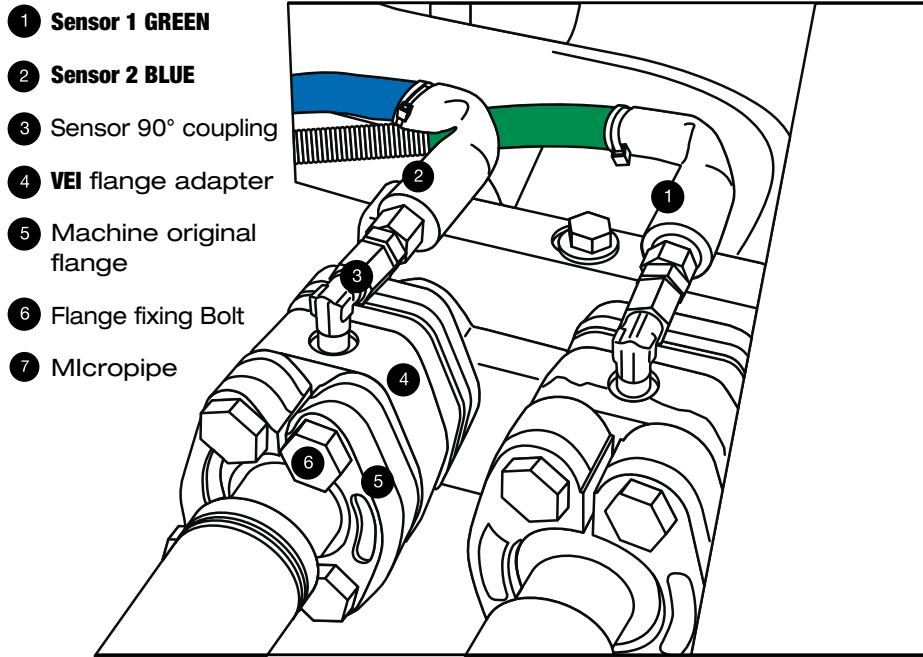
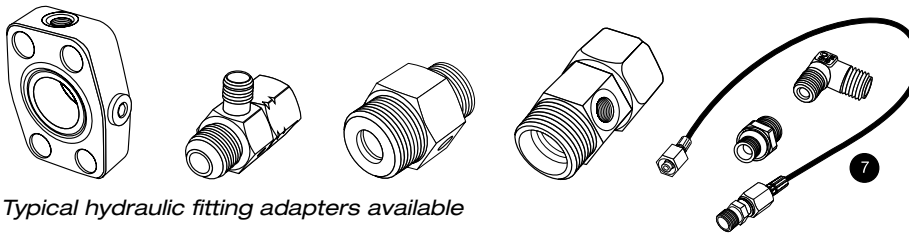

Illustration example of sensor fitting with flange



1.. Remove original fitting

Open the machine original fitting unscrewing the 4 bolts



Fig.2 Original fitting removed



Fig.1 Original fitting removal

2.. Install sensor's adapter

Place the Sensor's hydraulic adapter in place making sure it has the O-Ring mounted on it. Re-install then the original fitting and pipe with longer bolts where necessary; the bolts are not provided in the kit.



Fig.3 Vei flange fitting install



Fig.4 Original fitting and pipe back in place



Fig.5 Fitting install completed

3.. Install sensors

Fit the Sensors into the hydraulic port of the hydraulic fitting using the sensor's hydraulic coupling. In this example it is a 90°, in other cases it can be a straight coupling.

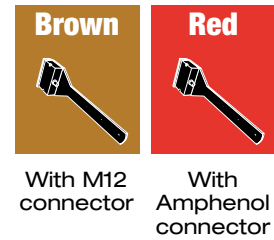

Fig.6 Sensors fitted into Vei fitting

Weighing Zone Sensor

Loader Installation Guide

The Weighing Zone Sensor is installed near the cabin front side on the machine's body, close to the lifting arm's pin area. Together with the metal Reference this sensor triggers the Device weighing. In fact while lifting the machine's arm, the metal Reference passes in front of the Weighing Zone Sensor and in this moment the weight is displayed on the Device. This is why this sensor is so called Weighing Zone, in fact weighing is not performed in any other position than this one.



1.. Arm positioning

Position the arm as on fig.1; the bucket pin should be just above the lifting arm pin. In this position the Device should start weighing, displaying LIFT while the metal Reference goes from the bottom to the top of the Weighing Zone Sensor.

IMPORTANT: start of weighing should be with the lifting pistons inclined as the green line in fig.1. Avoid to weigh when the lifting pistons are horizontal.

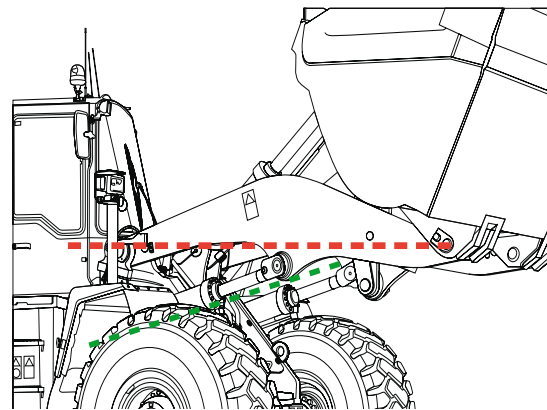

Fig.1 Weighing starting point

2.. Install Weighing Zone Sensor

Position the weighing zone sensor bracket on the machine's body close to the arm's pin then mark its location where it will be installed.



Fig.2 Weighing Zone bracket position

Drill and tap M8A the desired location. Drilling and tapping is not always required neither permitted; in some machines you can drill a bracket already on the machine and used for something else or weld a piece of steel where you have pre-drilled two holes for the sensor bracket fixing points.



Fig.3 Drilling Weighing Zone bracket fixing points



Fig.4 Tapping Weighing Zone bracket fixing points

Install the sensor bracket with 2 M8A x 16mm screws provided in the kit



Fig.5 Tapping Weighing Zone bracket fixing points

The Weighing Zone Sensor has a working direction which depends from the Weighing Preference, Weighing Direction setting. As default the Working Direction is set as “from Proximity 1 to Proximity 2”, illustrated in fig.6.

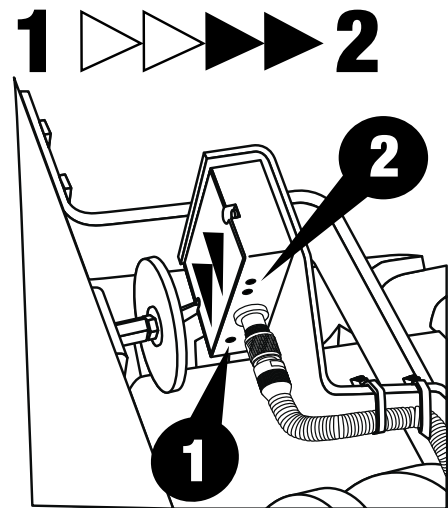

Fig.6 Weighing Zone 1 to 2 working direction

In case of mechanical restrictions you need to install the sensor up side down, as in fig.7, remember to set the Weighing Direction Preference as “from Proximity 2 to Proximity 1”.

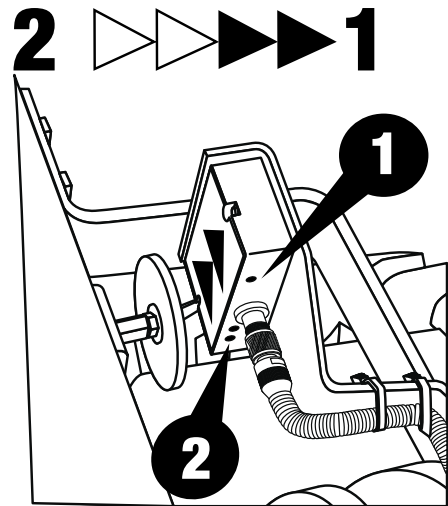

Fig.7 Weighing Zone 2 to 1 working direction

As a rule of thumb when the Weighing Zone sensor is facing Left the Weighing direction is “from Proximity 1 to Proximity 2”, instead when the sensor is facing Right it is the opposite.

3.. Install Weighing Reference

Once the weighing zone sensor is fixed on, place the magnetized Weighing Reference (VEI part # R00606), fig.8, on the arm and try out the position. If you don't have this part you can proceed to the next step.

REMEMBER:

- lift the arm up and down and make sure the weighing reference doesn't hit somewhere
- the starting weighing point should be when the bucket's pin is just above the arm's pin and the lifting piston no horizontal but inclined up
- make sure no other metal object belonging to the machine is entering the weighing zone sensor sensitive distance, 13mm/1/2"

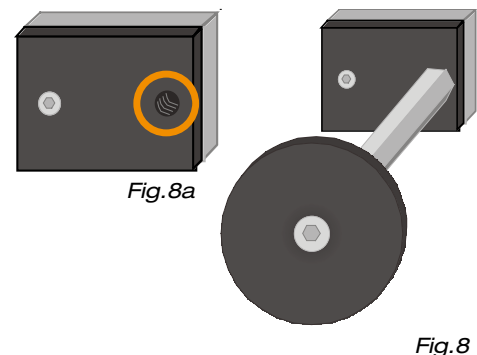

Fig.8a

Fig.8

Once you are sure about the Reference position, mark the arm by taking the hexagonal round reference holder off from the magnet to mark through the hole of it (fig.8a). Then drill and tap an M8A thread.



Fig.9 Drilling Weighing Zone reference fixing point



Fig.10 Tapping Weighing Zone reference fixing point

Install the M8A x 30mm headless screw Reference holder provided in the kit. Leave at least 12mm - 1/2" thread out.



Fig.11 Installing Weighing Zone reference headless screw

The Weighing Reference round disk can be then installed together with the exagonal spacer. The spacer can be adjusted properly (or cut in case it is too long) in order for the Weighing Reference to be within the sensitive distance from the sensor (13mm - 1/2" maximum)



Fig.12 Installing Weighing Zone reference hexagon



Fig.13 Weighing Zone reference disk

Harnesses wiring

Loader Installation Guide

Run your cables towards the cabin where the Device is gonna be installed. Care must be taken to avoid breakages when the machine is working. Follow the machine's pipeline and you will be safe. Fix the harness with cable tie being careful not to tight them too much



Fig.1 Harness on machine rotation

Find a hole or a cable path under the cabin and pull the cables up. If there is no possibilities to pull the cables up, you must drill a hole paying attention to where no machine's wiring is on the way.

The dimension of the hole you have to make is about 50mm or 2" in case the connectors are already soldered on the cables. If the cables have no connectors on it then the hole could be 25mm or 1".

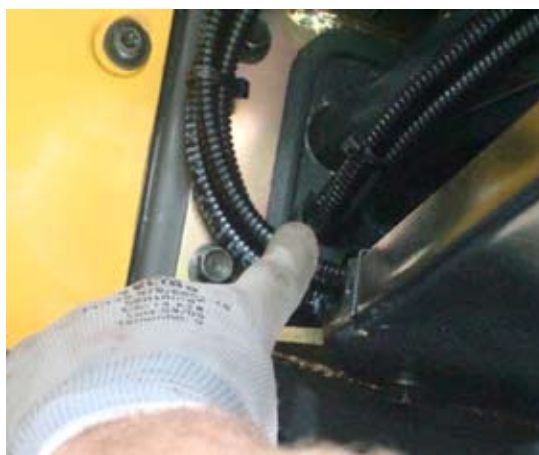

Fig.2 Harness entering the cabin from below



Fig.3 Harness entering the cabin from top

Bring the cables under the dashboards to finally take them to the right cabin's pillar where the Device will be installed



Fig.4 Harness fixed onto the pillar

Power Supply

Loader Installation Guide

Connect the Power Supply wires to 12 or 24VDC power source. It is always better if your ground is the machine's ground. The Power Supply can be taken from the ignition key, the cigaret lighter or the fuse box being careful to have a direct power source without solenoids or other devices in between. As an example never take the Power Supply from the same source of the Radio over voice transmitter.

Once you have found you Power Supply shut down the Machine power before making any connection



Fig.1 Machine power shut down key

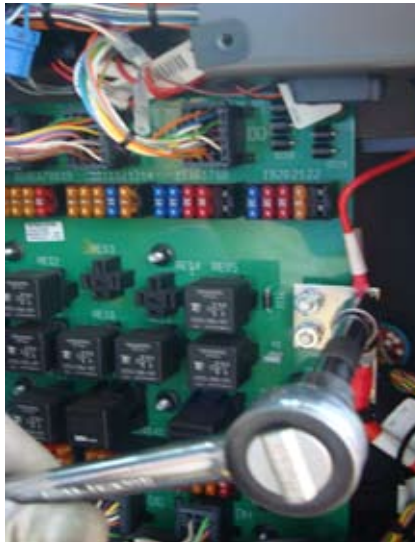

Fig.2 Power supply



Fig.3 Power ground

Device Mounting

Loader Installation Guide

Install the Device on the right side of the cabin, fixing its swivel bracket onto the cabin pole. Position the Device to clearly see it from the driving seat.

1.. Install Device bracket

Install the Device bracket into the cabin pole. The bracket can be fixed by drilling and tapping two M8A threads. Use the M8Ax14mm screws provided in the kit.



Fig.10

... Alternatives

Alternatively you can use existing threaded holes on the machine pillar. The example on fig.11 shows the Komatsu 7 series pillar which has a free hole threaded metric M10. Therefore the standard Bracket can be fitted in it by using the headless M10 screw provided with it. The same concept can be applied on CATs G and H series.



Fig.11 Komatsu -7 series cabin pillar has M10 female thread

This example is showing a CAT 924K pilar where the plastic cover must be taken off to install in this case 2 hexagons MA8 threaded on the inside where the Device bracket is fixed on.

Fig.12 and 13 show the pilar without and with plastic cover once the bracket fixing points have been installed on the pilar.



Fig.12 Cat 924K naked pilar



Fig.13 Cat 924K pilar with plastic cover

... with CAT K series

On Caterpillar K series loaders from the 950 model, the cabin pillar is hidden behind the plastic. You can use VEI kit providing an install kit which fixes on the machine pillar's plastic cover holding screws as in fig.14. Fig.15 shows the steel bar dimensions you need to manufacture in case you decide to do it locally.



Fig.14 Cat K series from 950 model

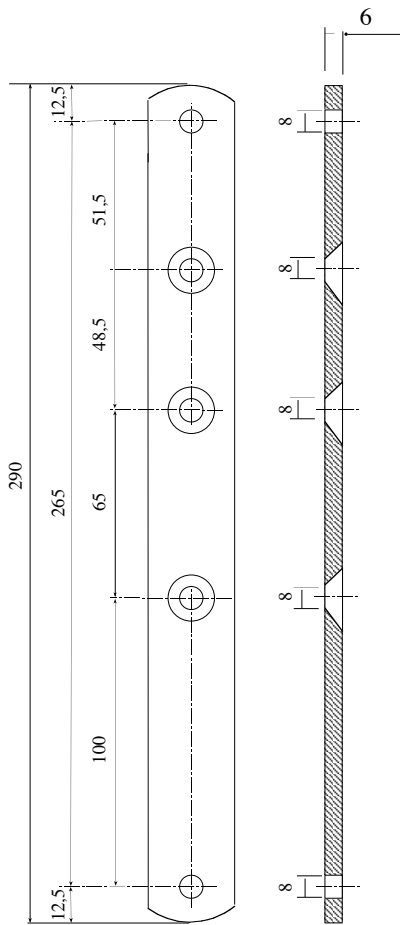

Fig.15 Cat K series pillar holding bracket. Part # R02263

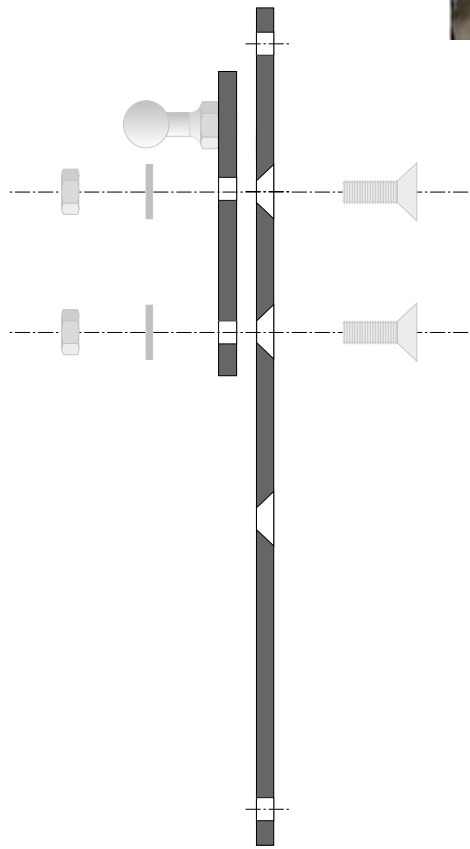

Fig.16 Cat K series pillar holding Bracket assembly with Bracket

... with Volvo G series

On Volvo G series loaders, the cabin pillar provides a plate where the Device bracket can be fixed on as on fig.17 and 18.



Fig.17 Volvo G series bracket close view

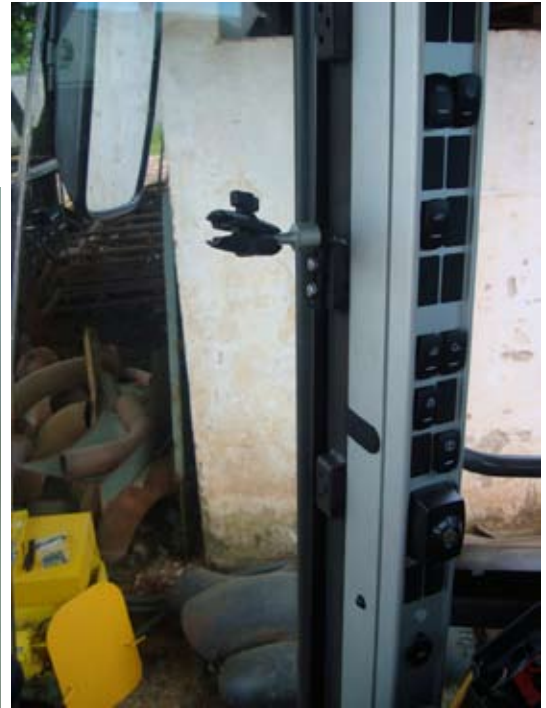

Fig.18 Volvo G series



Fig.19 Volvo G series with mirror command. The Device bracket can be fixed on 2 exagon in order to place the Device out of the rear view mirror command. As an alternative the mirror command can be slid up or down.

2.. Position the Device

Position the Device directly in front of the user to have best visibility. Fig.19 shows the Millennium5 device with vprint printer attached underneath.



Fig.19 Device positioning on Volvo G series

Printer Mounting

Loader Installation Guide

The vprint Printer can be installed underneath the Device which is the best choice for the user to have everything in the same spot. If it is not possible then the Printer can be installed separately. Be aware that in this case the cable harness to the device has a different length, and you might need a different fixing bracket other than the one supplied to attach the printer underneath the Device.

1.. Install Printer underneath the Device

Install the vprint Printer underneath the device with the bracket and screws provided in the kit.

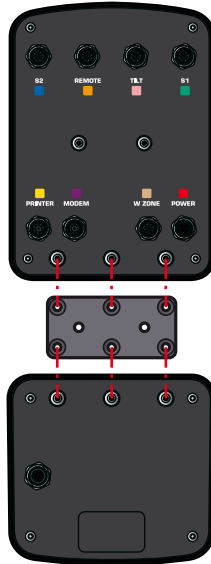

Fig.20

Fix the vprint underneath the Device with the provided plate. You need a 4mm allen key



Fig.21

Device and vprint in place

2.. Connect Printer harness

Connect the vprint Printer harness, one side to the vprint port and the other side to the Device "printer" port.

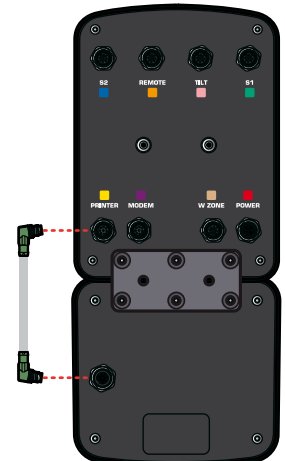
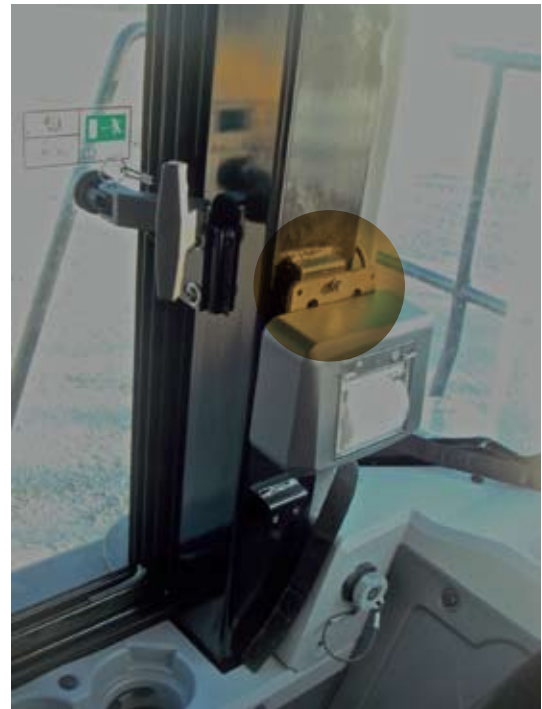

Fig.22

Device and vprint cable connection

3.. Install Printer separately

To install the vprint Printer separately you need a longer connection harness to the Device and the RAM type swivel bracket to position it as you like. Alternatively you can use the bracket plate to attach the printer underneath the Device provided in the kit.



*Fig.23
vprint fixed separately on the rear right pillar of a CAT cabin. Pilar provides an holding bracket with holes*

4.. Enable Printer

The Printer must be enabled in Print Preferences, Printer.

MAIN PAGE	PREFERENCES	PRINT	PRINTER
Weights on Hold	Print	Printer	Enable <input checked="" type="checkbox"/>
Weighing Mode			vprint <input checked="" type="checkbox"/>
Files			TM295
Weights Log File			
Preferences			

System Configuration Wizard

Loader Installation Guide

The Default Preferences of the Device are already right for a general working condition except for the calibration. Anyhow after installation run the System Configuration Wizard which will drive you through the main Preferences and Calibration. We advise to look into the Navigation and Editing chapters before operating with the Device. Please refer to the Preferences of Weighing, System, Print or Wireless to set the Device according to your specific need as some of these Preferences are not included into the Wizard.

1.. Run System Configuration Wizard

MAIN PAGE	PREFERENCES	UTILITY
Weights on Hold	Utility	System Configuration Wizard
Weighing Mode		
Files		
Weights Log File		
Preferences		

Start Key (F3) →



Press this key (F4) to terminate the wizard at any time



Press this key (F2) to continue with the wizard

WARNING

Are you sure you want to run the System Configuration Wizard?

CONFIRM

System Configuration Wizard starting.
Please wait...

2.. Wizard is running

The Wizard runs through the following Preferences of System, Weighing, Print and Tool Calibration in sequence; they can be left as they are or changed as you like.

... System Preferences

LANGUAGE	DATE FORMAT	DATE AND TIME	MACHINE CODE
English	DD-MM-YYYY	Day	Enable
Italiano	MM-DD-YYYY	Month	Code
Deutsch		Year	
...continues		Hours	
		Minutes	
WELCOME MESSAGE			
Enable			
Line 1			
Line 2			

... Print Preferences

PRINTER
Enable
vPRINT
TM295

... Weighing Preferences

The Weighing Software Preference must be DYN for loaders or other applications where two pressure sensors are required for a lifting cylinder with the main and return pressure ports. Settings depends upon your specific calibration.

UNIT OF MASS	SCALE INTERVAL	WEIGHING SOFTWARE	NO.OF WEIGHT SENSORS
kg	1	DYN	1 Sensor
t	2	STA	2 Sensors
lb	5	SPEED	
ton	10		
	20		
	50		
	100		
S2 COMPATIBILITY	WEIGHING DIRECTION		
Helper P5	From Prox1 to Prox2		
Helper 7	From Prox2 to Prox1		
Millennium			
Millennium5/HelperX			

... Tool Calibration

CONFIRM With the Tool closed and unloaded lift at low speed.	CONFIRM Load the Known Weight onto the Tool, press OK and set the value.
Weight (t) Edit the weight just loaded into the tool.	CONFIRM With the Tool closed and the Known Weight loaded, lift at low speed.
CONFIRM With the Tool closed and the Known Weight loaded, lift at high speed.	CONFIRM Slowly reposition the Tool in the Weighing zone.
CONFIRM You have reached the tip Off position. Press OK to continue.	CONFIRM Calibration in progress. Please wait...
CONFIRM Calibration successfully completed.	

3.. Wizard is completed

With the Calibration the System Configuration Wizard is completed.

CONFIRM
System Configuration Wizard completed.

Accuracy control

Loader Installation Guide

After the Wizard is completed and therefore the Device calibrated check the accuracy by loading a vehicle or container you can run on a weighing bridge to have its weight checked and compared to the total weight given by the Device. Before doing so you have to check the weight result of a single tool load by lifting at low and high rpm.

1.. Lifting speed check

In the Weighing window and with the tool fully loaded, lift the tool at low and high rpm. The two partial weights so obtained must differ from each other maximum two Scale Divisions which is the smallest weight increment (10,20,50 etc.). If the difference of these two weights is bigger, the Sensor 2 Gain must be adjusted. Sensor 2 Gain is related to the Sensor connected to the return pressure and plugged into the S2 port of the Device. The adjustment of the Sensor 2 Gain is by trial applying this procedure:

- a. Lift at low speed and record the weight
- b. lift at high speed and record the weight
- c. if the weight recorded at high speed is bigger than the one recorded at low speed, lower the Sensor 2 Gain by 0,1000 step and try again step a. and b. to see if the difference is smaller now. If not lower again the Sensor 2 Gain and continue

checking

If instead the weight recorded at high speed is smaller than the one recorded at low speed, increase the Sensor 2 Gain applying the same procedure as in c.

- d. When the weight result difference between low and high speed lift is equal or smaller than 2 Scale Divisions, the calibration is terminated.

To change the tool parameters go to Tools Preferences and refer to this section in the Technical manual for further details.

The screenshot shows the software interface with the following components:

- MAIN PAGE:** A menu with options: Weights on Hold, Weighing Mode, Files, Weights Log File, and Preferences.
- TOOLS:** A list of tools: Tool 1, Tool 2, Tool 3, Tool 4, and Tool 5.
- TOOL 1 DETAILS:** A table showing parameters for Tool 1.

TOOL 1 DETAILS	Range
Enable	
Name	15 characters
Sensor 1 Gain (S1G)	from -3,2000 to 99,9999
Sensor 2 Gain (S2G)	from -3,2000 to 99,9999
General Weight Gain (GWG)	from -3,2000 to 99,9999
Tip Off Gain (TOG)	from -3,2000 to 99,9999

Tools key (F1) is indicated by a line pointing to the TOOLS menu.

2.. Weight Correction

Check the Device accuracy by loading a vehicle or container you can run on a weighing bridge to have its weight checked and compared to the total weight given by the Device. To adjust discrepancies apply the Weight Correction on Tools Calibration for the Tool you require.

The screenshot shows the software interface with the following components:

- MAIN PAGE:** A menu with options: Weights on Hold, Weighing Mode, Files, Weights Log File, and Preferences.
- TOOLS:** A list of tools: Tool 1, Tool 2, Tool 3, Tool 4, and Tool 5.
- TOOLS CALIBRATION:** A screen with options: Weight Correction and Calibrations.

Tools key (F1) is indicated by a line pointing to the TOOLS menu.

Calibration key (F4) is indicated by a line pointing to the TOOLS CALIBRATION menu.

Start Key (F3) is indicated by a line pointing to the Weight Correction option.



Press this key (F2) to continue with the Calibration



Press this key (F4) to terminate escape Calibration

WARNING

Are you sure you want to run the Weight Correction?

CONFIRM

Set the displayed weight.

Displayed Weight (t)

Edit the weight given by the Device. We advise this weight to be the Total loaded into a vehicle or container or even better the sum of three to five totals.

CONFIRM

Set the correct weight.

Correct Weight (t)

Edit the weight given by weighing system where the vehicle or container is checked. We advise this weight to be the Total loaded into a vehicle or container or even better the sum of three to five totals as you did above for the Displayed Weight.

CONFIRM

Calibration in progress.
Please wait...

CONFIRM

Calibration successfully completed.

Fork-Lift Truck



Load Sensor 1

Fork lift Installation Guide

Load Sensors 1 is installed along the hydraulic pipeline of the fork lift. Usually the lifting cylinder is of simple effect meaning there is no return line, this is why load Sensor 1 is installed, only. On big fork lift there might be cases where the lifting cylinder is of double effect, meaning it has the return line as well; in this case install Sensor 2 as you do on a front-end loader. The installation must be done the closest possible to the cylinder avoiding to have valves in between the cylinder and the sensor. The only acceptable valve that can exist is the parachute valve which prevents a sudden drop of the forks in case the hydraulic pipe breaks.



Avoid those positions where the sensor can be hit by rocks and other objects during working movements.

VEI has a selection of hydraulic fittings to cover some of the installations, not all due to the vast range of fork lift models in the market. In case a fork lift model is not covered, please provide us with all the technical info for the adapter and we will try to include it into our database and manufacturing schedule.

Follow these simple steps to install the sensor. The example shows a JIC fitting but it can be any other type of adapter.

- ① Sensor 1 GREEN
- ② Sensor 90° coupling
- ③ VEI adapter
- ④ Cylinder hydraulic pipe

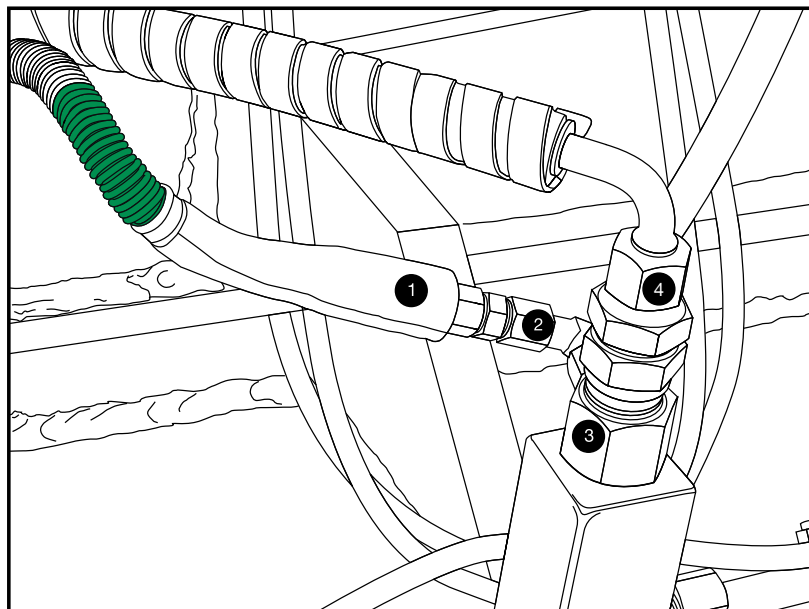
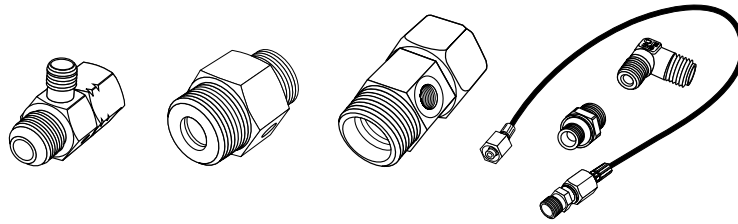

Illustration example of sensor fitting with JIC adapter



Typical hydraulic fitting adapters available

1.. Remove pipe

Open the cylinder's hydraulic pipe (4).

2.. Install sensor's adapter

Place the Sensor's hydraulic adapter (3) in place making sure it has the O-Ring mounted on it (if this is the case). Re-install then the cylinder's hydraulic pipe into VEI adapter (4).

3.. Install sensors

Fit the Sensor into the hydraulic port of the hydraulic fitting using the sensor's hydraulic coupling (2). In this example it is a 90°, in other cases it can be a straight coupling.

Weighing Zone Sensor

Fork lift Installation Guide

The Weighing Zone Sensor is installed up front the fork lift, close to the lifting mast if not in itself. Together with the metal Reference this sensor triggers the Device weighing. In fact while lifting the forks, the metal Reference passes in front of the Weighing Zone Sensor and in this moment the weight is displayed on the Device. This is why this sensor is so called Weighing Zone, in fact weighing is not performed in any other position than this one.

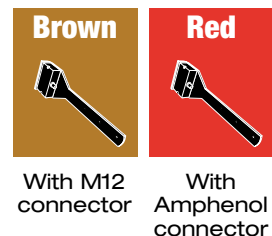

1.. Tool carrier positioning

Position the forks about 2 feet from ground as on fig.1. In this position the Device should start weighing, displaying LIFT while the metal Reference goes from the bottom to the top of the Weighing Zone Sensor.

Important: We advise to weigh with the mast retracted back in order to have a fixed position and avoid accuracy problems due to the change in center of gravity when the mast is positioned differently in every weighing.

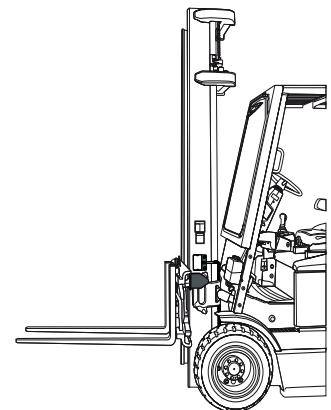

Fig. 1

2.. Install Weighing Zone Sensor

Position the weighing zone sensor bracket on the mast, then mark its location where it will be installed. Drill and tap M8A the desired location. Drilling and tapping is not always required neither permitted; you can drill a bracket already on the fork lift truck and used for something else or weld a piece of iron where you have pre-drilled two holes for the sensor bracket fixing points. Install the sensor bracket with 2 M8A x 16mm screws provided in the kit

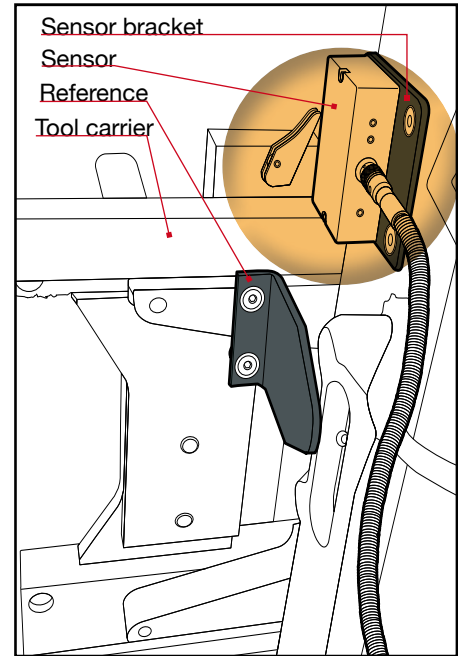

Fig. 2

The Weighing Zone Sensor has a working direction which depends from Weighing Preference, Weighing Direction setting. As default the Working Direction is set as “from Proximity 1 to Proximity 2”, illustrated in fig.3.

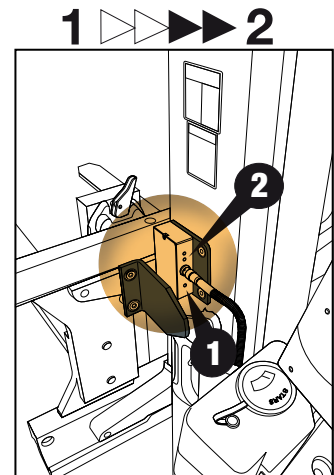

Fig. 3

In case of mechanical restrictions you need to install the sensor up side down, as in fig.4, remember to set the Weighing Direction Preference as “from Proximity 2 to Proximity 1”.

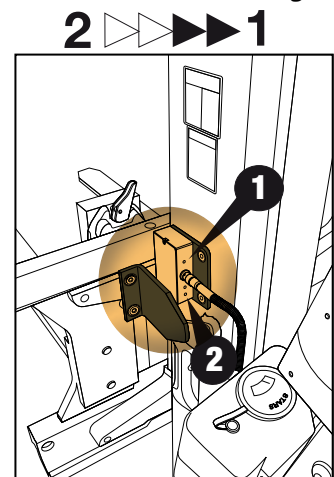

Fig. 4

As a rule of thumb when the Weighing Zone sensor is facing Left the Weighing direction is “from Proximity 1 to Proximity 2”, instead when the sensor is facing Right it is the opposite.

3.. Install Weighing Reference

Once the weighing zone sensor is fixed on, place the Weighing Reference on the tool carrier plate and try out the position.

REMEMBER:

- a. lift the mast up and down and make sure the weighing reference doesn't hit somewhere
- b. make sure no other metal object belonging to the machine is entering the weighing zone sensor sensitive distance, 13mm/1/2"

Once you are sure about the Reference position, mark the mast and then drill and tap an M8A thread.

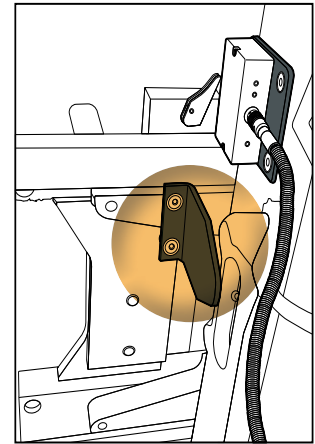

Fig. 5

Harnesses wiring

Fork lift Installation Guide

Run your cables towards the Device. Care must be taken to avoid breakages when the fork lift truck is working. Follow the hydraulic pipeline and you will be safe.

Find a hole or a cable path under the footrest and pull the cables up towards the Device. If there is no possibilities to pull the cables up, you must drill a hole paying attention to where no machine's wiring is on the way. The dimension of the hole you have to make is about 50mm or 2" in case the connectors are already soldered on the cables. If the cables have no connectors on it then the hole could be 25mm or 1".

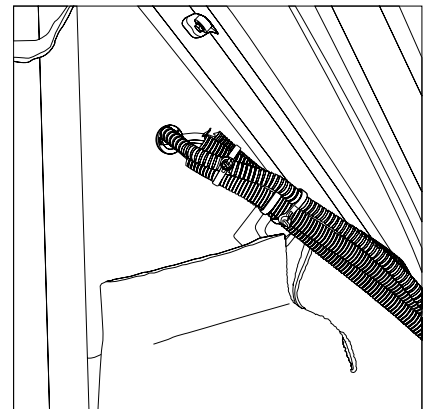

Fig. 6

Power Supply

Fork lift Installation Guide

Connect the Power Supply wires to 12 or 24VDC power source. It is better if your ground is the fork lift truck ground. The Power Supply can be taken from the ignition key, the cigaret lighter or the fuse box being careful to have a direct power source without solenoids or other devices in between.



Device Mounting

Fork lift Installation Guide

Install the Device on the right side of driving position, fixing its swivel bracket onto the front pole or on the dashboard. Position the Device to clearly see it from the driving seat.

1.. Install Device bracket

The bracket can be fixed by drilling and tapping two M8A threads. Use the M8Ax14mm screws provided in the kit.



Fig.7

Printer Mounting

Fork lift Installation Guide

The vprint Printer can be installed underneath the Device which is the best choice for the user to have everything in the same spot. If it is not possible then the Printer can be installed separately. Be aware that in this case a supplement kit must be ordered. The supplement kit includes the swivel bracket and a longer cable harness to the Device. At your choice you can use the bracket provided when the printer is installed underneath the Device being aware it is not swivel type.

1.. Install Printer underneath the Device

Install the vprint Printer underneath the device with the bracket and screws provided in the kit.

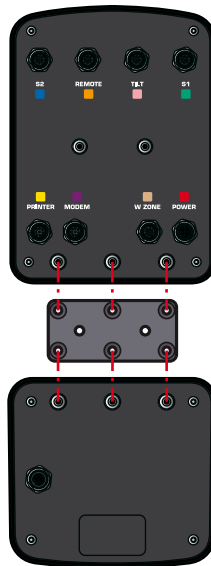

Fig.8

Fix the vprint underneath the Device with the provided plate. You need a 4mm allen key



Fig.9

Device and vprint in place

2.. Connect Printer harness

Connect the vprint Printer harness, one side to the vprint port and the other side to the Device "printer" port.

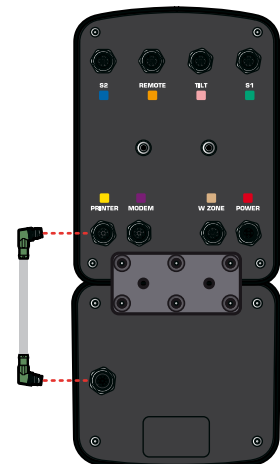

Fig.22

Device and vprint cable connection

4.. Enable Printer

The Printer must be enabled in Print Preferences, Printer.

MAIN PAGE	PREFERENCES	PRINT	PRINTER
Weights on Hold	Print	Printer	Enable <input type="radio"/>
Weighing Mode			vprint <input checked="" type="checkbox"/>
Files			TM295
Weights Log File			
Preferences			

System Configuration Wizard

Fork lift Installation Guide

After installation run the System Configuration Wizard which will drive you through the main Preferences and Calibration. We advise to look into the Navigation and Editing chapters before operating with the Device. Please refer to the Preferences of Weighing, System, Print or Wireless to set the Device according to your specific need as some of these Preferences are not included into the Wizard.

1.. Run System Configuration Wizard

MAIN PAGE	PREFERENCES	UTILITY
Weights on Hold	Utility	System Configuration Wizard
Weighing Mode		
Files		
Weights Log File		
Preferences		

Start Key (F3)



Press this key (F4) to terminate the wizard at any time



Press this key (F2) to continue with the wizard

WARNING

Are you sure you want to run the System Configuration Wizard?

CONFIRM

System Configuration Wizard starting.
Please wait...

2.. Wizard is running

The Wizard runs through the following Preferences of System, Weighing, Print and Tool Calibration in sequence; they can be left as they are or changed as you like.

... System Preferences

LANGUAGE	DATE FORMAT	DATE AND TIME	MACHINE CODE
English	DD-MM-YYYY	Day	Enable
Italiano	MM-DD-YYYY	Month	Code
Deutsch		Year	
...continues		Hours	
		Minutes	
WELCOME MESSAGE			
Enable			
Line 1			
Line 2			

... Print Preferences

PRINTER
Enable
vPRINT
TM295

... Weighing Preferences

The Weighing Software Preference must be SPEED for fork lifts with one pressure sensor because of a single port cylinder and weighing without stopping the mast. If instead the fork lift truck application requires to stop the mast for weighing, the Preference must be set as STA.

UNIT OF MASS	SCALE INTERVAL	WEIGHING SOFTWARE	NO.OF WEIGHT SENSORS
kg	1	DYN	1 Sensor
t	2	STA	2 Sensors
lb	5	SPEED	
ton	10		
	20		
	50		
	100		
S2 COMPATIBILITY		WEIGHING DIRECTION	
Helper P5		From Prox1 to Prox2	
Helper 7		From Prox2 to Prox1	
Millennium			
Millennium5/HelperX			

... Tool Calibration

CONFIRM With the Tool closed and unloaded lift at low speed.	CONFIRM With the Tool closed and unloaded lift at medium speed.
CONFIRM With the Tool closed and unloaded lift at high speed.	CONFIRM Load the Known Weight onto the Tool press OK and set the value.
Weight (t) Edit the weight just loaded into the tool.	CONFIRM With the Tool closed and the Known Weight loaded, lift at low speed.
CONFIRM With the Tool closed and the Known Weight loaded, lift at medium speed.	CONFIRM With the Tool closed and the Known Weight loaded, lift at high speed
CONFIRM Slowly reposition the Tool in the Weighing zone.	CONFIRM You have reached the Tip Off position. Press OK to continue.
CONFIRM Calibration in progress please wait...	CONFIRM Calibration successfully completed

3.. Wizard is completed

With the Calibration the System Configuration Wizard is completed.

CONFIRM
System Configuration Wizard completed.

Accuracy control

Fork lift Installation Guide

After the Wizard is completed and therefore the Device calibrated check the accuracy by loading a vehicle or container you can run on a weighing bridge to have its weight checked and compared to the total weight given by the Device. Before doing so you have to check the weight result of a single tool load by lifting at low and high rpm.

1.. Lifting speed check

In the Weighing window and with the tool loaded with at least 50% of the nominal capacity, lift the tool at low and high rpm. The two partial weights so obtained must differ from each other maximum one Scale Divisions which is the smallest weight increment (5,10,20,50 etc.). If the difference of these two weights is bigger, you must fine tune the calibration parameters.

- Lift at slow speed and record the weight
- lift at high speed and record the weight
- if the weight recorded at high speed has a difference more than one Scale Division, increase the Fast Time (FT) parameter, in this way lifting at the speed giving an error is not possible anymore.
- If the error still persists, the Tool Calibration must be done again.

To change the tools parameters go to Tools Preferences and refer to this section in the Technical manual for further details.

MAIN PAGE		TOOLS		TOOL 1 DETAILS		Range
Weights on Hold		Tool 1		Enable		
Weighing Mode		Tool 2		Name		15 characters
Files		Tool 3		Slow Lift Gain (SLG)		from 0,2000 to 99,9999
Weights Log File		Tool 4		Medium Lift Gain (MLG)		from -99,9999 to 99,9999
Preferences		Tool 5		Fast Lift Gain (FLG)		from -99,9999 to 99,9999
				Slow Time (ST)		from >medium time to 6,0
				Medium Time (MT)		from >fast to <slow time
				Fast Time (FT)		from 0,05 to <medium time
				Zero Slow Lift (ZSL)		from -32000 to 32000
				Zero Medium Lift (ZML)		from -32000 to 32000
				Zero Fast Lift (ZFL)		from -32000 to 32000
				Zero Medium Time (ZMT)		from >fast to <slow time
				Tip Off gain (TOG)		from 0,2000 to 99,9999

Tools key (F1)

WARNING

Do you want to also update the Fast Gain and Fast Zero Empty values?

EXPLANATION

This warning message appears when changing the Fast Time. Answer YES if you are changing the parameter to adjust the calibration.

2.. Weight Correction

Check the Device accuracy by loading a vehicle or container you can run on a weighing bridge to have its weight checked and compared to the total weight given by the Device. To adjust discrepancies apply the Weight Correction on Tools Calibration for the Tool you require.

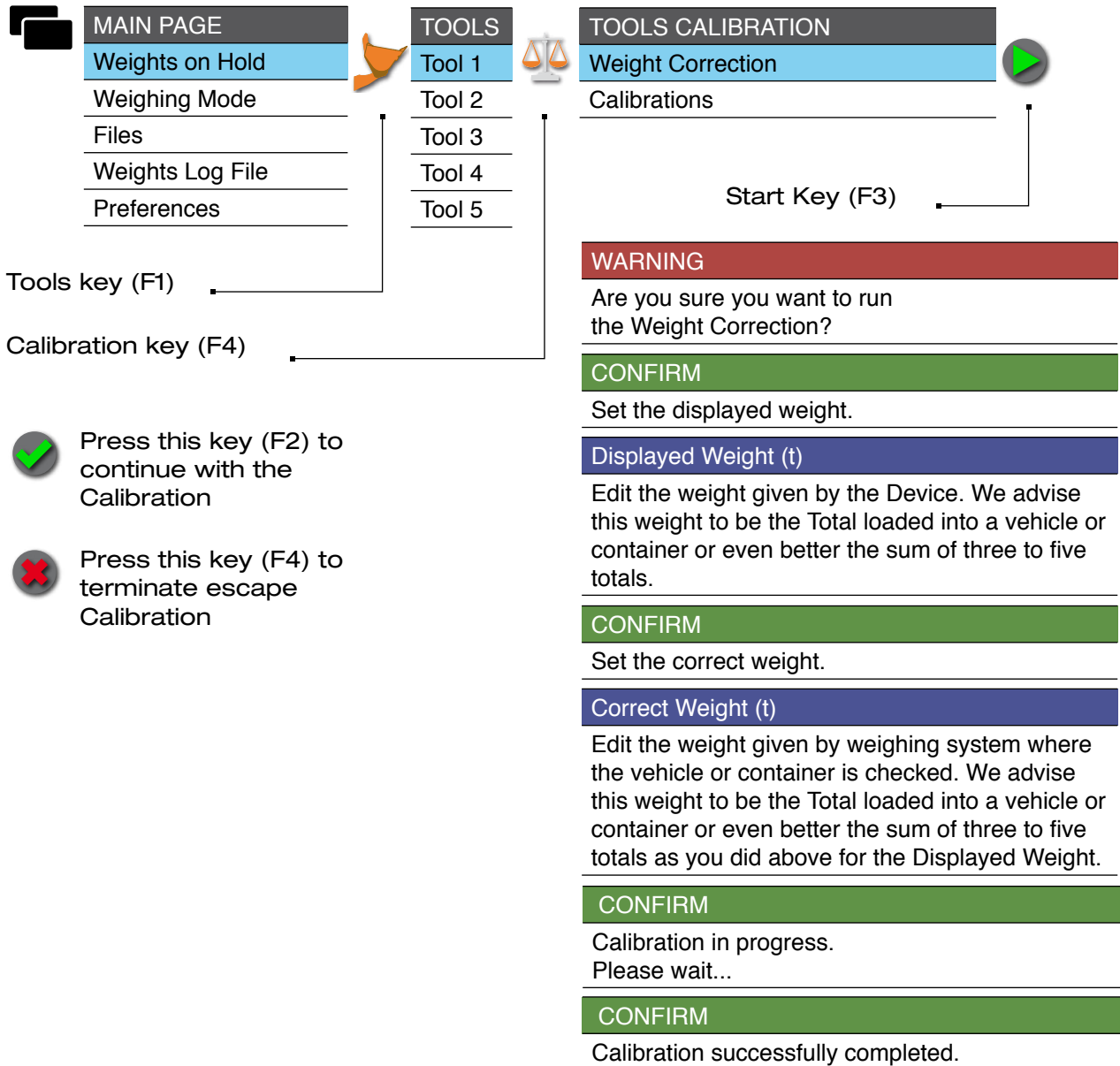

Telescopic Loader



Load Sensors 1 & 2

Telescopic Loader Installation Guide

Load Sensors 1 and 2 are installed along the lifting cylinder hydraulic pipeline of the machine. The installation must be done the closest possible to the cylinder avoiding to have valves in between the cylinder and the sensor. However in most telescopic loader you can't avoid to install the sensors after the parachute valve because it is located just at the exit of the cylinder main pressure port.

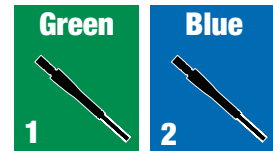

Avoid those positions where:

- a. The sensor can be hit by rocks and other objects during working movements.
- b. The cylinder is moving up and down, so is the sensor. If you have no other choice, then do it, carefully making sure the sensors are safe at any movement of the cylinder or use VEI micropipe (7) to bring the sensors in a protected area.

VEI has a selection of hydraulic fittings to cover all the installations. In case a machine model is not covered, please provide us with all the technical info for the adapter and we will try to include it into our database and manufacturing schedule.

Follow these simple steps to install the sensors. The example shows a JIC fitting but it can be any other type of adapter.

- 1 Sensor 1 **GREEN**
- 2 Sensor 2 **BLUE**
- 3 VEI adapter
- 4 Sensor 90° coupling
- 5 Cylinder hydraulic pipe

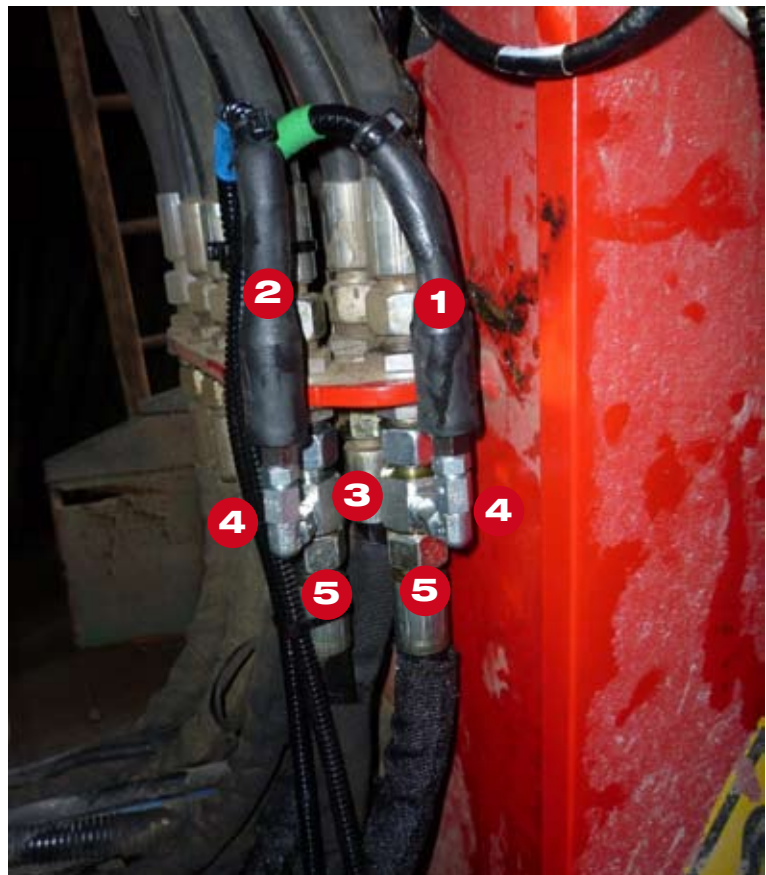

Fig.1 machine's hydraulic pipes

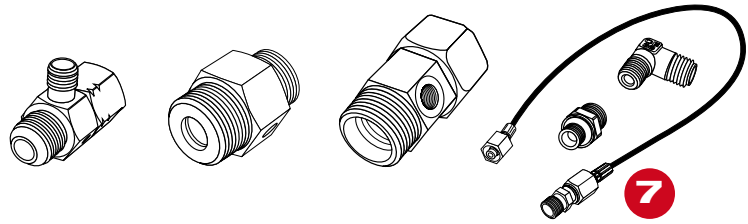

Fig.2 Typical hydraulic fitting adapters available

1.. Remove pipe

Open the cylinder's hydraulic pipe (5).

2.. Install sensor's adapter

Place the Sensor's hydraulic adapter (3) in place making sure it has the O-Ring mounted on it (if this is the case). Re-install then the cylinder's hydraulic pipe (5) into VEI adapter.

3.. Install sensors

Fit the Sensor into the hydraulic port of the hydraulic fitting using the sensor's hydraulic coupling (4). In this example it is a 90°, in other cases it can be a straight coupling.

Weighing Zone Sensor

Telescopic Loader Installation Guide

The Weighing Zone Sensor is installed in the machine's body near the boom rotating point. Together with the metal Reference this sensor triggers the Device weighing. In fact while lifting the machine's boom, the metal Reference passes in front of the Weighing Zone Sensor and in this moment the weight is displayed on the Device. This is why this sensor is so called Weighing Zone, in fact weighing is not performed in any other position than this one.

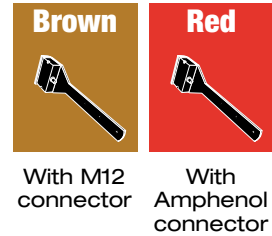

1.. Arm positioning

Position the boom as on fig.1 to determine the weighing starting point. In this position the Device should start weighing, displaying LIFT while the metal Reference goes from the bottom to the top of the Weighing Zone Sensor



Fig. 1 Boom position at the beginning of the weighing

2.. Install Weighing Zone Sensor

Position the weighing zone sensor bracket on the machine's body close to the arm's pin then mark its location where it will be installed. Drill and tap M8A the desired location. Drilling and tapping is not always required neither permitted; in some machines you can drill a bracket already on the machine and used for something else or weld a piece of steel where you have pre-drilled two holes for the sensor bracket fixing points. Install the sensor bracket with 2 M8A x 16mm screws provided in the kit.

Position the bracket's head as on fig.2 paying attention to align the head with the boom's pivoting pin as showing with the green line. This will give best weighing accuracy.



Fig. 2 Weighing Zone sensor position in line with boom's pin

3.. Install Weighing Zone Reference

Position the Weighing Zone Reference in a way that goes through the Weighing Sensor in a straight line from bolt to bolt of the Weighing zone sensor as shown by the red line.



Fig. 3 Weighing Zone Reference moving position through the Weighing Zone Sensor

Once you are sure about the Reference position, mark the boom. Then drill and tap an M8A thread.

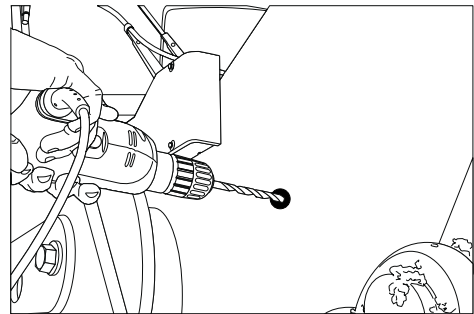

Fig. 4 Drilling

Install the M8A x 30mm headless screw Reference holder provided in the kit. Leave at least 12mm - 1/2" thread out.

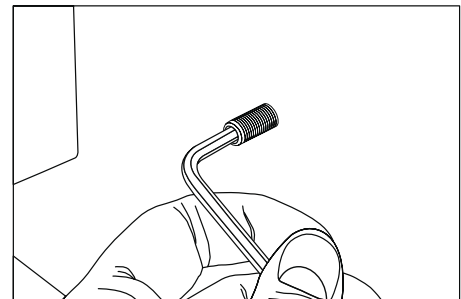

Fig. 5 Installing the headless screw

The Weighing Reference round disk can be then installed together with the exagonal spacer. The spacer can be adjusted properly (or cut in case it is too long) in order for the Weighing Reference to be within the sensitive distance from the sensor (13mm - 1/2" maximum)

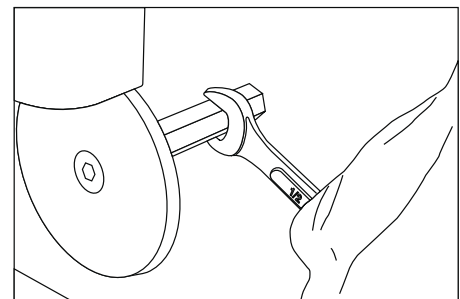

Fig. 6 Installing the Weighing Zone Reference

Harnesses wiring

Telescopic Loader Installation Guide

Run your cables towards the cabin where the Device is gonna be installed. Care must be taken to avoid breakages when the machine is working. Follow the machine's pipeline and you will be safe.

Find a hole or a cable path under the cabin and pull the cables up. If there is no possibilities to pull the cables up, you must drill a hole paying attention to where no machine's wiring is on the way.

The dimension of the hole you have to make is about 50mm or 2" in case the connectors are already soldered on the cables. If the cables have no connectors on it then the hole could be 25mm or 1".

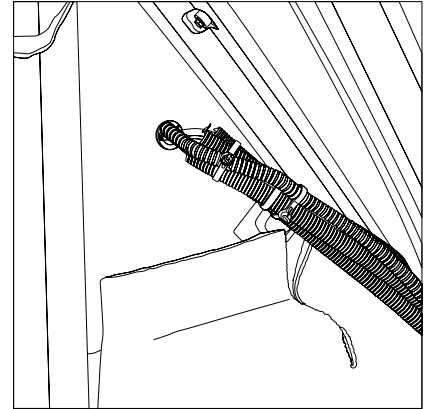

Fig.1

Power Supply

Telescopic Loader Installation Guide

Connect the Power Supply wires to 12 or 24VDC power source. It is always better if your ground is the machine's ground. The Power Supply can be taken from the ignition key, the cigaret lighter or the fuse box being careful to have a direct power source without solenoids or other devices in between. As an example never take the Power Supply from the same source of the Radio over voice transmitter.



Device Mounting

Telescopic Loader Installation Guide

Install the Device on the right side of the cabin, fixing its swivel bracket onto the cabin pole. Position the Device to clearly see it from the driving seat.

1.. Install Device bracket

Install the Device bracket into the cabin pillar. The bracket can be fixed by drilling and tapping two M8A threads. Use the M8Ax14mm screws provided in the kit.



Fig.1 Device Bracket fixed onto the cabin pillar

2.. Position the Device

Position the Device directly in front of the user to have best visibility. Fig.2 shows the Millennium5 device without vprint printer attached underneath.



Fig.2 Device positioning

Printer Mounting

Telescopic Loader Installation Guide

The vprint Printer can be installed underneath the Device which is the best choice for the user to have everything in the same spot. If it is not possible then the Printer can be installed separately. Be aware that in this case the cable harness to the device has a different length, and you might need a different fixing bracket other than the one supplied to attach the printer underneath the Device.

1.. Install Printer underneath the Device

Install the vprint Printer underneath the device with the bracket and screws provided in the kit.

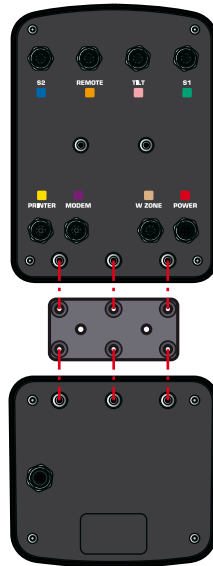

Fig.1

Fix the vprint underneath the Device with the provided plate. You need a 4mm allen key



Fig.2

Device and vprint in place

2.. Connect Printer harness

Connect the vprint Printer harness, one side to the vprint port and the other side to the Device "printer" port.

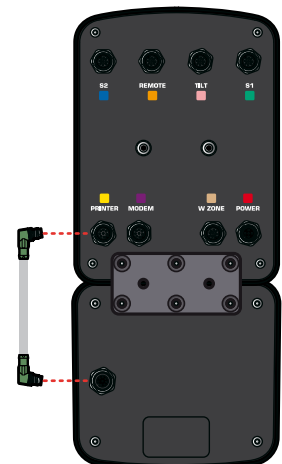

Fig.3

Device and vprint cable connection

3.. Install Printer separately

To install the vprint Printer separately you need a longer connection harness to the Device and the RAM type swivel bracket to position it as you like. Alternatively you can use the bracket plate to attach the printer underneath the Device provided in the kit.



*Fig.4
vprint fixed separately on the rear right pillar of a cabin using the standard plate to attach the printer underneath the Device*

4.. Enable Printer

The Printer must be enabled in Print Preferences, Printer.

MAIN PAGE	PREFERENCES	PRINT	PRINTER
Weights on Hold	Print	Printer	Enable <input checked="" type="radio"/>
Weighing Mode			vprint <input checked="" type="checkbox"/>
Files			TM295
Weights Log File			
Preferences			

System Configuration Wizard

Telescopic Loader Installation Guide

The Default Preferences of the Device are already right for a general working condition except for the calibration. Anyhow after installation run the System Configuration Wizard which will drive you through the main Preferences and Calibration. We advise to look into the Navigation and Editing chapters before operating with the Device. Please refer to the Preferences of Weighing, System, Print or Wireless to set the Device according to your specific need as some of these Preferences are not included into the Wizard.

1.. Run System Configuration Wizard

MAIN PAGE	PREFERENCES	UTILITY
Weights on Hold	Utility	System Configuration Wizard
Weighing Mode		
Files		
Weights Log File		
Preferences		

Start Key (F3)



Press this key (F4) to terminate the wizard at any time



Press this key (F2) to continue with the wizard

WARNING

Are you sure you want to run the System Configuration Wizard?

CONFIRM

System Configuration Wizard starting.
Please wait...

2.. Wizard is running

The Wizard runs through the following Preferences of System, Weighing, Print and Tool Calibration in sequence; they can be left as they are or changed as you like.

... System Preferences

LANGUAGE	DATE FORMAT	DATE AND TIME	MACHINE CODE
English	DD-MM-YYYY	Day	Enable
Italiano	MM-DD-YYYY	Month	Code
Deutsch		Year	
...continues		Hours	
		Minutes	
WELCOME MESSAGE			
Enable			
Line 1			
Line 2			

... Print Preferences

PRINTER
Enable
vPRINT
TM295

... Weighing Preferences

The Weighing Software Preference must be DYN

UNIT OF MASS	SCALE INTERVAL	WEIGHING SOFTWARE	NO.OF WEIGHT SENSORS
kg	1	DYN	1 Sensor
t	2	STA	2 Sensors
lb	5	SPEED	
ton	10		
	20		
	50		
	100		

S2 COMPATIBILITY	WEIGHING DIRECTION
Helper P5	From Prox1 to Prox2
Helper 7	From Prox2 to Prox1
Millennium	
Millennium5/HelperX	

... Tool Calibration

IMPORTANT: When lifting the Boom bring the lifting lever all the way back and towards you in order to keep the tool all retracted back.

CONFIRM	CONFIRM
With the Tool closed and unloaded lift at low speed.	Load the Known Weight onto the Tool, press OK and set the value.
Weight (t)	CONFIRM
Edit the weight just loaded into the tool.	With the Tool closed and the Known Weight loaded, lift at low speed.
CONFIRM	CONFIRM
With the Tool closed and the Known Weight loaded, lift at high speed.	Slowly reposition the Tool in the Weighing zone.
CONFIRM	CONFIRM
You have reached the tip Off position. Press OK to continue.	Calibration in progress. Please wait...
CONFIRM	
Calibration successfully completed.	

3.. Wizard is completed

With the Calibration the System Configuration Wizard is completed.

CONFIRM

System Configuration Wizard completed.

Accuracy control

Telescopic Loader Installation Guide

After the Wizard is completed and therefore the Device calibrated check the accuracy by loading a vehicle or container you can run on a weighing bridge to have its weight checked and compared to the total weight given by the Device. Before doing so you have to check the weight result of a single tool load by lifting at low and high rpm.

IMPORTANT: When lifting the Boom bring the lifting lever all the way back and towards you in order to keep the tool all retracted back.

1.. Lifting speed check

In the Weighing window and with the tool fully loaded, lift the tool at low and high rpm. The two partial weights so obtained must differ from each other maximum two Scale Divisions which is the smallest weight increment (10,20,50 etc.). If the difference of these two weights is bigger, the Sensor 2 Gain must be adjusted. Sensor 2 Gain is related to the Sensor connected to the return pressure and plugged into the S2 port of the Device.

The adjustment of the Sensor 2 Gain is by trial applying this procedure:

- Lift at low speed and record the weight
- lift at high speed and record the weight
- if the weight recorded at high speed is bigger than the one recorded at low speed, lower the Sensor 2 Gain by 0,1000 step and try again step a. and b. to see if the difference is smaller now. If not lower again the Sensor 2 Gain and continue checking.
If instead the weight recorded at high speed is smaller then the one recorded at low speed, increase the Sensor 2 Gain applying the same procedure as in c.
- When the weight result difference between low and high speed lift is equal or smaller than 2 Scale Divisions, the calibration is terminated.

To change the tool parameters go to Tools Preferences and refer to this section in the Technical manual for further details.

The screenshot shows a menu structure with the following elements:

- MAIN PAGE** (highlighted): Weights on Hold, Weighing Mode, Files, Weights Log File, Preferences.
- TOOLS** (highlighted): Tool 1, Tool 2, Tool 3, Tool 4, Tool 5.
- TOOL 1 DETAILS** (highlighted): Enable, Name, Sensor 1 Gain (S1G), Sensor 2 Gain (S2G), General Weight Gain (GWG), Tip Off Gain (TOG).
- Range** (highlighted): 15 characters, from -3,2000 to 99,9999.

Navigation arrows indicate the path: MAIN PAGE → TOOLS → TOOL 1 DETAILS → Range.

Tools key (F1)

2.. Weight Correction

Check the Device accuracy by loading a vehicle or container you can run on a weighing bridge to have its weight checked and compared to the total weight given by the Device. To adjust discrepancies apply the Weight Correction on Tools Calibration for the Tool you require.

IMPORTANT: When lifting the Boom bring the lifting lever all the way back and towards you in order to keep the tool all retracted back.

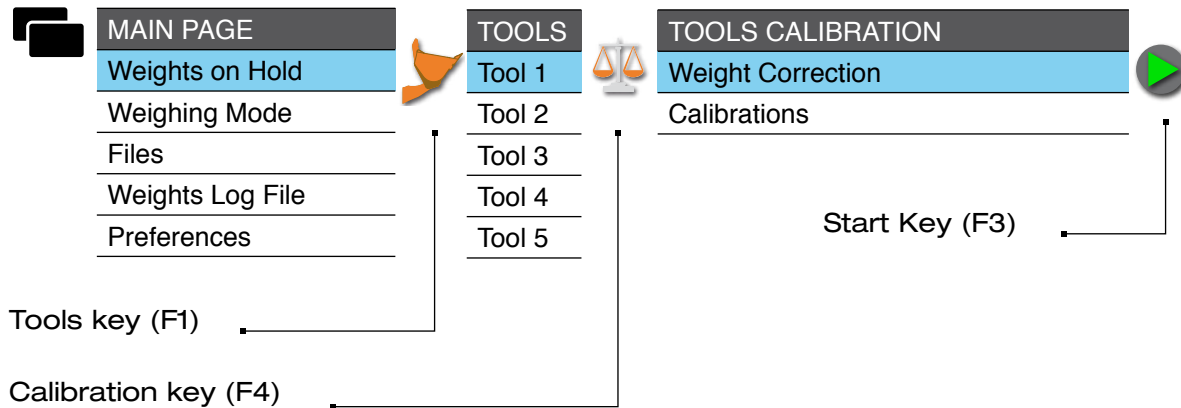

Press this key (F2) to continue with the Calibration



Press this key (F4) to terminate escape Calibration

WARNING

Are you sure you want to run the Weight Correction?

CONFIRM

Set the displayed weight.

Displayed Weight (t)

Edit the weight given by the Device. We advise this weight to be the Total loaded into a vehicle or container or even better the sum of three to five totals.

CONFIRM

Set the correct weight.

Correct Weight (t)

Edit the weight given by weighing system where the vehicle or container is checked. We advise this weight to be the Total loaded into a vehicle or container or even better the sum of three to five totals as you did above for the Displayed Weight.

CONFIRM

Calibration in progress. Please wait...

CONFIRM

Calibration successfully completed.

Articulated Dump Truck



Load Sensors 1 & 2

ADT Installation Guide

Load Sensors 1 and 2 are installed along the Dump truck walking beam, one on the left and one on the right side. The cable loom is marked with Green rubber for one Load Link and Blue rubber for the other one. This marking is just to identify them along the truck wiring; in fact they are connected together into the Device S1 channel.

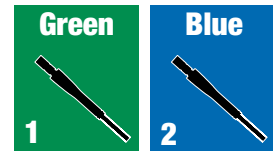

1.. Plate welding

Weld first the Load Link sensor's plate, without Load Link on it, into the walking beam as shown in fig.2. As you see in fig.1 the position is almost in the middle between the tip of the walking beam and its end towards the cabin.

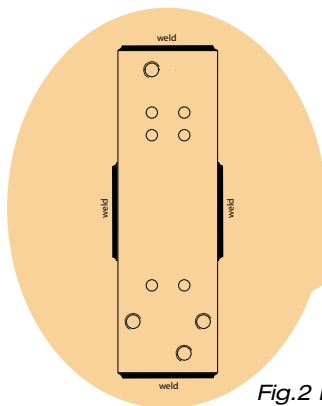

Fig.2 Load Link plate



Fig.1 ADT walking beam with Load Links on it

2.. Load Link fitting

Fit the MA5 headless screws provided in the kit into the Load Link plate just welded.

Install then the Load Link into the headless screws and tight them down with the self-locking nuts provided in the kit.

Close the nuts with 17 Newtons using an appropriate wrench.

BE AWARE that the LOAD LINK can work in compression or tension and because of this the signal connection must be proper. When you order the LOAD LINK from Vei you must specify the truck brand in order to receive the LOAD LINK correctly connected



Fig.3 Load Link fitting

3.. Load Link cover

Fit the Load Link cover on top of it and tight it down with the MA6 screws provided in the kit. The cable loom goes towards the cabin, if possible.



Fig.4 Load Link cover

Harnesses wiring

ADT Installation Guide

Run your cables towards the cabin where the Device is gonna be installed. Care must be taken to avoid breakages when the machine is working. Follow the machine's pipeline and you will be safe.

Find a hole or a cable path under the cabin and pull the cables up. If there is no possibilities to pull the cables up, you must drill a hole paying attention to where no machine's wiring is on the way. The dimension of the hole you have to make is about 50mm or 2" in case the connectors are already soldered on the cables. If the cables have no connectors on it then the hole could be 25mm or 1".



Fig.1 Load Link wiring towards the cabin

1.. Load Link junction connection

Join the Load Link harnesses into the Y splice usually located within the truck pipes going into the cabin. This position is ideal for future inspections but it can be anywhere as long as the harnesses are long enough.



Fig.2 Load Links Y splice junction

Find a hole or a cable path on the cabin and pull the cables up. If there is no possibilities to pull the cables up, you must drill a hole paying attention to where no machine's wiring is on the way.

Power Supply

ADT Installation Guide

Connect the Power Supply wires to 12 or 24VDC power source. It is always better if your ground is the machine's ground. The Power Supply can be taken from the ignition key, the cigaret lighter or the fuse box being careful to have a direct power source without solenoids or other devices in between. As an example never take the Power Supply from the same source of the Radio over voice transmitter.



Device Mounting

ADT Installation Guide

Install the Device on the right side of the cabin, fixing its swivel bracket onto the cabin pole. Position the Device to clearly see it from the driving seat.

1.. Install Device bracket

Install the Device bracket into the cabin pillar. The bracket can be fixed by drilling and tapping two M8A threads. Use the M8Ax14mm screws provided in the kit.



Fig.1 Device Bracket fixed onto the cabin pillar

2.. Position the Device

Position the Device directly in front of the user to have best visibility. Fig.2 shows the Millennium5 device without vprint printer attached underneath.



Fig.2 Device positioning

Printer Mounting

ADT Installation Guide

The vprint Printer can be installed underneath the Device which is the best choice for the user to have everything in the same spot. If it is not possible then the Printer can be installed separately. Be aware that in this case the cable harness to the device has a different length, and you might need a different fixing bracket other than the one supplied to attach the printer underneath the Device.

1.. Install Printer underneath the Device

Install the vprint Printer underneath the device with the bracket and screws provided in the kit.

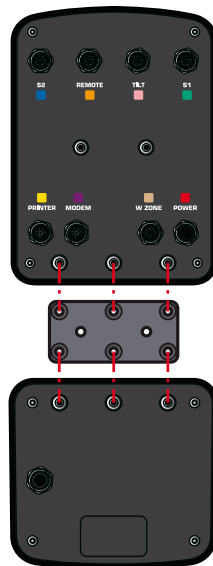

Fig.1

Fix the vprint underneath the Device with the provided plate. You need a 4mm allen key

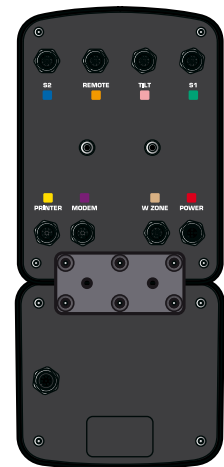

Fig.2

Device and vprint in place

2.. Connect Printer harness

Connect the vprint Printer harness, one side to the vprint port and the other side to the Device "printer" port.

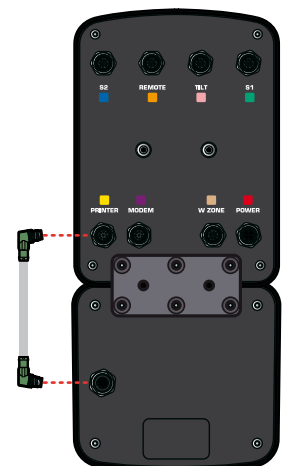

Fig.3

Device and vprint cable connection

3.. Install Printer separately

To install the vprint Printer separately you need a longer connection harness to the Device and the RAM type swivel bracket to position it as you like. Alternatively you can use the bracket plate to attach the printer underneath the Device provided in the kit.



*Fig.4
vprint fixed separately on the rear right pillar of a cabin using the standard plate to attach the printer underneath the Device*

4.. Enable Printer

The Printer must be enabled in Print Preferences, Printer.

MAIN PAGE	PREFERENCES	PRINT	PRINTER
Weights on Hold	Print	Printer	Enable <input checked="" type="radio"/>
Weighing Mode			vprint <input checked="" type="checkbox"/>
Files			TM295
Weights Log File			
Preferences			

Weighing Button

ADT Installation Guide

The weight value is in real time in the Partial field but in order to memorize it, send it wireless and print it, the weighing must be triggered by a push button connected to the Device W.Zone port if your Device has M12 connectors or into the Power port together with the power cable if instead your Device has Amphenol connectors. The Weighing Button comes connected into the Power Connector but if it doesn't the 2 wires must be connected to Ground (pin 2) the common contact and PROX1 (pin 4) the contact.



Fig.1
Device with AMPHENOL
connectors. Weighing button
is connected to Power



Fig.2
Device with M12 connectors.
Weighing button is
connected to W.zone

1.. Weighing procedure

Before leaving the loading site, push the #2 key, the Device shows STOP. Hold down the #2 key until Stop disappears and the weight is displayed on the Partial field.



Fig.3
Weighing Button

System Configuration Wizard

ADT Installation Guide

The Default Preferences of the Device are already right for a general working condition except for the calibration. Anyhow after installation run the System Configuration Wizard which will drive you through the main Preferences and Calibration. We advise to look into the Navigation and Editing chapters before operating with the Device. Please refer to the Preferences of Weighing, System, Print or Wireless to set the Device according to your specific need as some of these Preferences are not included into the Wizard.

1.. Run System Configuration Wizard

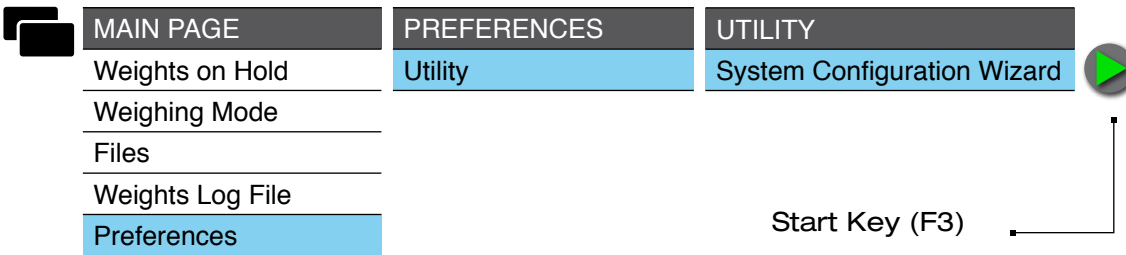

Press this key (F4) to terminate the wizard at any time



Press this key (F2) to continue with the wizard

WARNING

Are you sure you want to run the System Configuration Wizard?

CONFIRM

System Configuration Wizard starting.
Please wait...

2.. Wizard is running

The Wizard runs through the following Preferences of System, Weighing, Print and Tool Calibration in sequence; they can be left as they are or changed as you like.

... System Preferences

LANGUAGE	DATE FORMAT	DATE AND TIME	MACHINE CODE
English	DD-MM-YYYY	Day	Enable
Italiano	MM-DD-YYYY	Month	Code
Deutsch		Year	
...continues		Hours	
		Minutes	
WELCOME MESSAGE			
Enable			
Line 1			
Line 2			

... Print Preferences

PRINTER
Enable
vPRINT
TM295

... Weighing Preferences

The Weighing Software Preference must be STA

UNIT OF MASS	SCALE INTERVAL	WEIGHING SOFTWARE	NO.OF WEIGHT SENSORS
kg	1	DYN	1 Sensor
t	2	STA	2 Sensors
lb	5	SPEED	
ton	10		
	20		
	50		
	100		
		S2 COMPATIBILITY	WEIGHING DIRECTION
		Helper P5	From Prox1 to Prox2
		Helper 7	From Prox2 to Prox1
		Millennium	
		Millennium5/HelperX	

... Tool Calibration

CONFIRM	EXPLANATION
Run Weighing unloaded	With the truck unloaded push the weighing button until the "Lower Tool" confirmation window appears, then release the weighing button
CONFIRM	EXPLANATION
Load the Known Weight, press OK and set the value	Load the weight into the truck and press OK
Weight (t)	CONFIRM
30	Enter the weight of the load just loaded, for example 30t and press OK to confirm
CONFIRM	CONFIRM
Run Weighing with Known Weight loaded	Push the weighing button until you here a beep and the following confirmation appears
CONFIRM	
Calibration in progress. Please wait...	
CONFIRM	
Calibration successfully completed.	

3.. Wizard is completed

With the Calibration the System Configuration Wizard is completed.

CONFIRM
System Configuration Wizard completed.

Accuracy control

ADT Installation Guide

Check the Device accuracy by loading the truck with a machine having the on board weighing system or running the truck on a weighing bridge to have its weight checked and compared to the weight given by the Device.

To adjust discrepancies apply the Weight Correction on Tools Calibration.

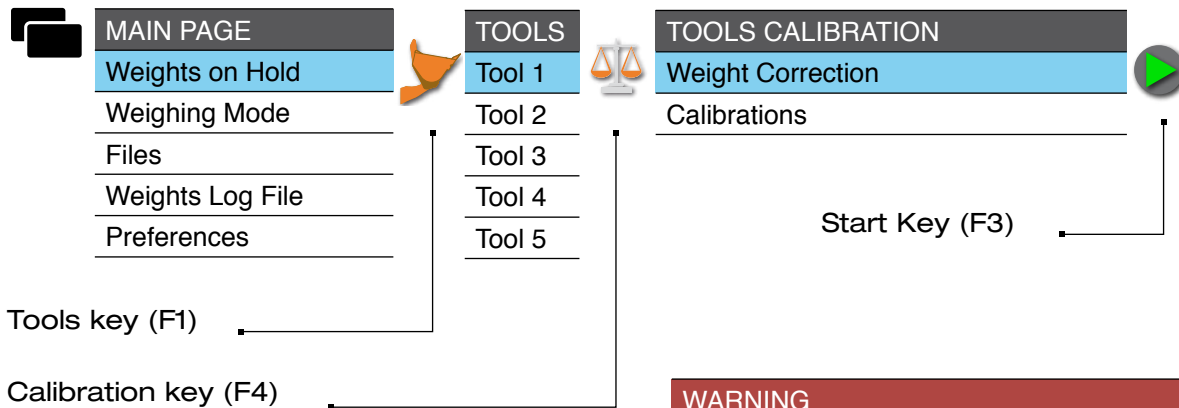

Press this key (F2) to continue with the Calibration

Press this key (F4) to terminate escape Calibration

WARNING

Are you sure you want to run the Weight Correction?

CONFIRM

Set the displayed weight.

Displayed Weight (t)

Edit the weight given by the Device.

CONFIRM

Set the correct weight.

Correct Weight (t)

Edit the weight given by the weighing system where the truck's load has been checked.

CONFIRM

Calibration in progress. Please wait...

CONFIRM

Calibration successfully completed.

Material Handler

Load Sensor 1

Material Handler Installation Guide

The Load Sensor is called GR2 Weighing Block and it is installed between the stick boom and the grapple or tool; GR2 replaces the original Yoke. The cable loom is marked with Green rubber to identify it along the machine's wiring and the Device connection port S1 which is marked Green as well.

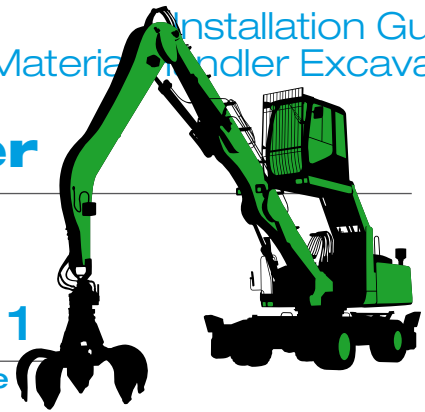

1.. Yoke Removal

Remove the original Yoke suspension from the stick boom and tool



Fig.1 Original Yoke installed



Fig.2 Original Yoke uninstalled

2.. GR2 Weighing Block installation into the stick boom

Lower slowly the boom and slide it into the GR2 Weighing Block upper plate



Fig.3 Sliding Stick boom into the GR2 upper plate

3.. GR2 Weighing Block installation into the tool head

Lift the stick boom with the GR2 Weighing Block on it and join the lower plate with the tool head. Make sure the GR2 hydraulic pipe containing the cable is free to move and bend as the other hydraulic pipes on the tool. Rotate the GR2 inward and outward to check the hydraulic pipe will not be damaged by any movements.

Note: The GR2 Weighing Block might be longer than the original Yoke. At the time you receive the GR2 drawing compare it with the original Yoke one to make sure the tool's hydraulic pipes are still long enough.



Fig.4 GR2 in place

4.. Quick disconnect plug

Mount the Quick disconnect Plug receptacle onto the stick boom.
Make first sure that the plug of the GR2 Weighing Block cable is long enough to the choosen location.

From the receptacle bring the cable inside the cabin following the stick and boom hydraulic pipes.
Connect then the cable to the Device S1 port



Fig.5 Quick disconnect plug onto the stick boom

Weighing Button

Material Handler Installation Guide

The weight value is in real time in the Partial field but in order to memorize it, send it wireless and print it, the weighing must be triggered by a push button or a pedal, as shown, connected to the Device W.Zone port if your Device has M12 connectors or into the Power port together with the power cable if instead your Device has Amphenol connectors. The Weighing Pedal comes connected into the Power Connector but if it doesn't the 2 wires must be connected to Ground (pin 2) the common contact and PROX1 (pin 4) the contact.

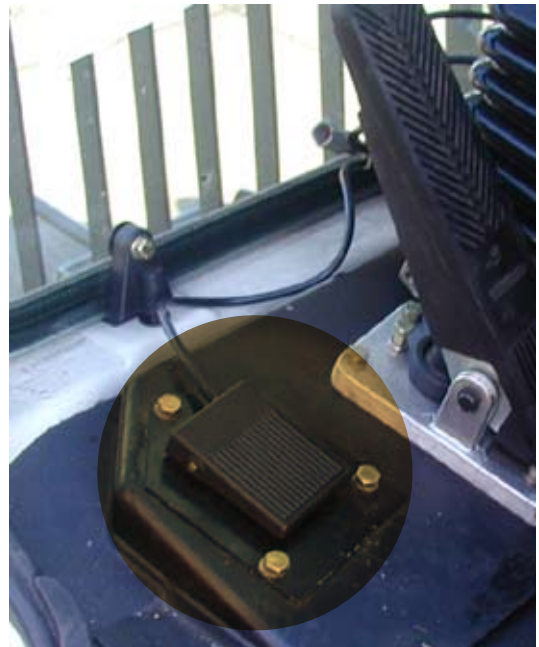

Fig.1 Weighing Pedal

1.. Weighing procedure

Lift the Tool off the material pile and push the pedal down, the Device shows STOP. Hold down the pedal until Stop disappears and the weight is displayed on the Partial field.

Power Supply

Material Handler Installation Guide

Connect the Power Supply wires to 12 or 24VDC power source. It is always better if your ground is the machine's ground. The Power Supply can be taken from the ignition key, the cigaret lighter or the fuse box being careful to have a direct power source without solenoids or other devices in between. As an example never take the Power Supply from the same source of the Radio over voice transmitter.



Device Mounting

Material Handler Installation Guide

Install the Device on the right side of the cabin, fixing its swivel bracket onto the cabin pole. Position the Device to clearly see it from the driving seat.

1.. Install Device bracket

Install the Device bracket into the cabin pillar. The bracket can be fixed by drilling and tapping two M8A threads. Use the M8Ax14mm screws provided in the kit.



Fig.1 Device Bracket fixed onto the cabin pillar

2.. Position the Device

Position the Device directly in front of the user to have best visibility. Fig.2 shows the Millennium5 device without vprint printer attached underneath.



Fig.2 Device positioning

Printer Mounting

Material Handler Installation Guide

The vprint Printer can be installed underneath the Device which is the best choice for the user to have everything in the same spot. If it is not possible then the Printer can be installed separately. Be aware that in this case the cable harness to the device has a different length, and you might need a different fixing bracket other than the one supplied to attach the printer underneath the Device.

1.. Install Printer underneath the Device

Install the vprint Printer underneath the device with the bracket and screws provided in the kit.



Fig.1

Fix the vprint underneath the Device with the provided plate. You need a 4mm allen key

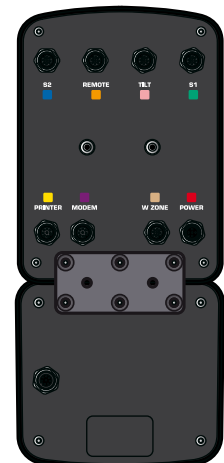
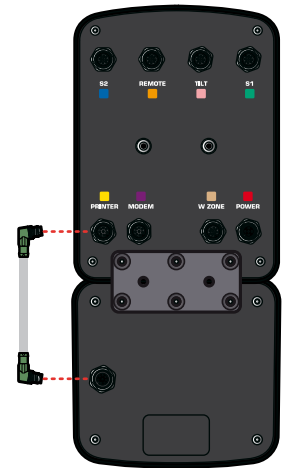

Fig.2

Device and vprint in place

2.. Connect Printer harness

Connect the vprint Printer harness, one side to the vprint port and the other side to the Device “printer” port.



*Fig.3
Device and vprint cable
connection*

3.. Install Printer separately

To install the vprint Printer separately you need a longer connection harness to the Device and the RAM type swivel bracket to position it as you like. Alternatively you can use the bracket plate to attach the printer underneath the Device provided in the kit.



*Fig.4
vprint fixed separately on
the rear right pillar of a cabin
using the standard plate to
attach the printer
underneath the Device*

4.. Enable Printer

The Printer must be enabled in Print Preferences, Printer.

MAIN PAGE	PREFERENCES	PRINT	PRINTER
Weights on Hold	Print	Printer	Enable <input type="radio"/>
Weighing Mode			vprint <input checked="" type="checkbox"/>
Files			TM295
Weights Log File			
Preferences			

System Configuration Wizard

Material Handler Installation Guide

The Default Preferences of the Device are already right for a general working condition except for the calibration. Anyhow after installation run the System Configuration Wizard which will drive you through the main Preferences and Calibration. We advise to look into the Navigation and Editing chapters before operating with the Device. Please refer to the Preferences of Weighing, System, Print or Wireless to set the Device according to your specific need as some of these Preferences are not included into the Wizard.

1.. Run System Configuration Wizard

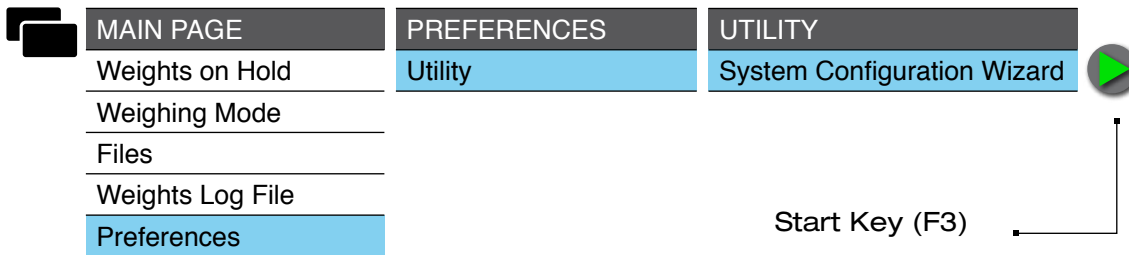

Press this key (F4) to terminate the wizard at any time



Press this key (F2) to continue with the wizard

WARNING

Are you sure you want to run the System Configuration Wizard?

CONFIRM

System Configuration Wizard starting.
Please wait...

2.. Wizard is running

The Wizard runs through the following Preferences of System, Weighing, Print and Tool Calibration in sequence; they can be left as they are or changed as you like.

... System Preferences

LANGUAGE	DATE FORMAT	DATE AND TIME	MACHINE CODE
English	DD-MM-YYYY	Day	Enable
Italiano	MM-DD-YYYY	Month	Code
Deutsch		Year	
...continues		Hours	
		Minutes	
WELCOME MESSAGE			
Enable			
Line 1			
Line 2			

... Print Preferences

PRINTER
Enable
vPRINT
TM295

... Weighing Preferences

The Weighing Software Preference must be STA

UNIT OF MASS	SCALE INTERVAL	WEIGHING SOFTWARE	NO.OF WEIGHT SENSORS
kg	1	DYN	1 Sensor
t	2	STA	2 Sensors
lb	5	SPEED	
ton	10		
	20		
	50		
	100		
S2 COMPATIBILITY	WEIGHING DIRECTION		
Helper P5	From Prox1 to Prox2		
Helper 7	From Prox2 to Prox1		
Millennium			
Millennium5/HelperX			

... Tool Calibration

The Device comes already calibrated with its GR2 Weighing Block, therefore skip this procedure.

CONFIRM	
Calibration Starting...	
CONFIRM	EXPLANATION
Run Weighing unloaded	 Press F3 to escape calibration
CONFIRM	
Calibration interrupted	

3.. Wizard is completed

Having interrupted the calibration the Wizard is interrupted as well. It doesn't matter Calibration was the last step of it.

WARNING

Are you sure you want to interrupt the System Configuration Wizard?

EXPLANATION

Press F2 to confirm

WARNING

System Configuration Wizard Interrupted

Zero at Empty

Material Handler Installation Guide

When delivered the Device is already calibrated. Now you have to do the Zero at empty with the tool hanging from the GR2 Weighing Block.

- 1 With the Tool not touching the ground Hold down the Weighing Pedal or Button



- 2 The Device shows STOP until the weight value is displayed. Avoid abrupt movements during this time

STEVE		01/14/14 10:45
TOTAL	ton	PARTIAL
STOP		1.98
PRODUCT		
SCRAP ALUMINUM		
CUSTOMER		
GREEN PLANT INC		

- 3** Release the Weighing Pedal or Button once STOP disappears and you here the buzzer

STEVE		01/14/14 10:45	
TOTAL	ton	PARTIAL	
1.98	¹	1.98	¹
PRODUCT			
SCRAP ALUMINUM			
CUSTOMER			
GREEN PLANT INC			

- 4** Hold down the >0< key to perform the Zero at Empty



- 5** The Partial field is cleared to zero; Zero at Empty is accomplished

STEVE		01/14/14 10:45	
TOTAL	ton	PARTIAL	
0.00	¹	0.00	⁰
PRODUCT			
SCRAP ALUMINUM			
CUSTOMER			
GREEN PLANT INC			

Accuracy control

Material Handler Installation Guide

Check the Device accuracy by loading a truck or container you can run on a weighing bridge to have its weight checked or grab a known weight into the Tool.
To adjust discrepancies apply the Weight Correction on Tools Calibration.

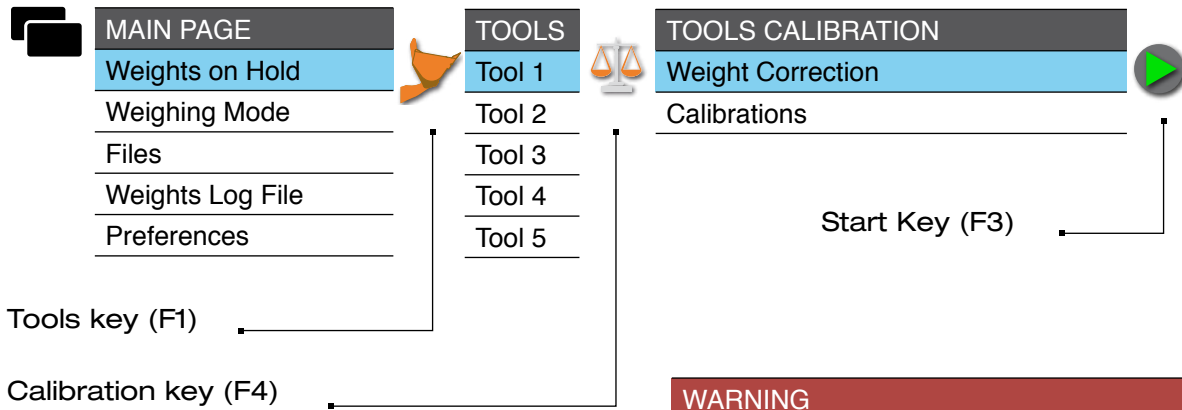

Press this key (F2) to continue with the Calibration

Press this key (F4) to terminate escape Calibration

WARNING

Are you sure you want to run the Weight Correction?

CONFIRM

Set the displayed weight.

Displayed Weight (t)

Edit the weight given by the Device.

CONFIRM

Set the correct weight.

Correct Weight (t)

Edit the weight given by the weighing system where the truck's load has been checked or the known weight grabbed into the tool

CONFIRM

Calibration in progress. Please wait...

CONFIRM

Calibration successfully completed.

