

QUAD 1000

OWNERS MANUAL – OPERATION GUIDE



L LASERLINE MFG., INC.
www.laserlinemfg.com

REV. 6.15.18

COMPONENTS

4001-0000 Quad 1000 5 arc second zenith laser featuring electronic servo self-leveling with variable temperature compensation for the most accurate and consistent readings. Features downward shooting laser plumb-bob for getting over your point, upward zenith laser to 1,200 feet (366m), one button operation with LCD display and up to 140 hrs. battery life.



4200-0000 Trivet Floor Mount with a 5/8 x 11 thread mount and adjustable legs. Made of heavy duty aluminum with a finished textured black E-coating surface and a handle on each side for easy, safe positioning.



4001-0010 Target Template (2ea.) with “ultra-bright” bulls-eye for the most visible and precise readings at any distance. One target features a ¼ inch pass through hole allowing multiple readings at one time. The second target is solid making it easy for setting an instrument over as a reference point. Special hard coating that protects the graphics on the target face and two ¼ inch holes for custom mounting.

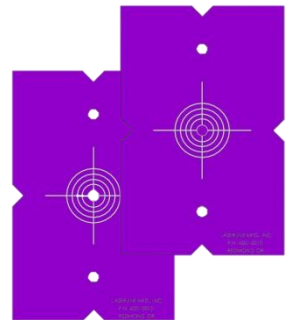

4000-0200 Carrying Case double wall blow molded, custom fit foam inserts and two locking latches for securing your items.



4001-XXXX Owner's Manual - Operators Guide

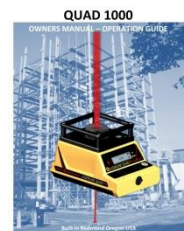

OVERVIEW

The Quad 1000 projects a precise laser beam straight up (Zenith) to 1,200 feet/366m for the purpose of providing plumb control for your project. It also features a short range downward shooting laser beam that is used like a plumb-bob or optical tribrach to easily get directly over your point.

The Quad 1000 is a self-leveling instrument with electronic temperature compensation. It measures or senses ambient temperature changes while in operation and continually recalibrates itself to maintain the highest degree of accuracy possible. This insures consistent, accurate readings for plumb control on your project throughout the course of the job.

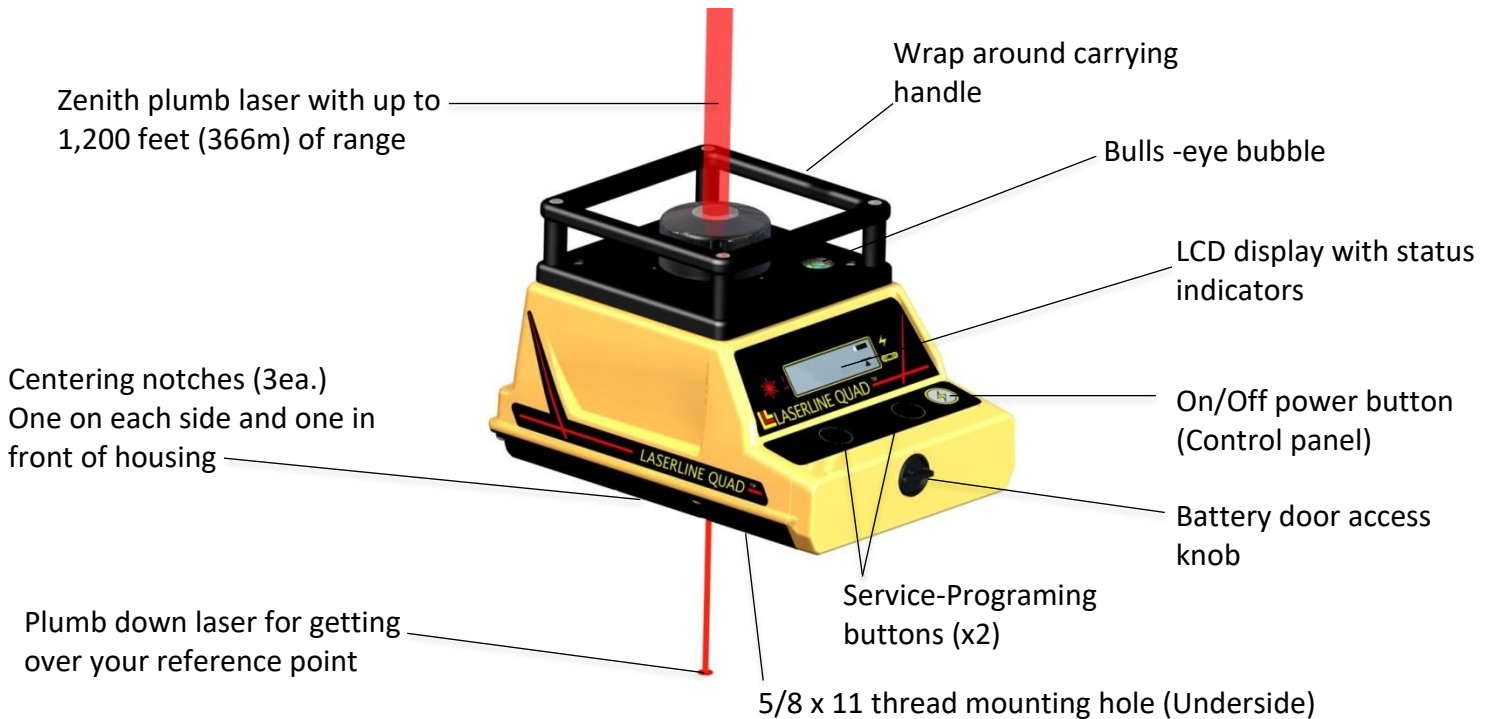

WHAT HAPPENS WHEN YOU POWER-UP?

The Quad 1000 is activated and controlled by a single button. When you push the power button, the unit begins to self-level. Leveling status and battery power are displayed on the LCD screen. The downward shooting smaller beam (plumb-bob) is activated and will be blinking. Once the Quad has self-leveled to within its operating spec, the plumb-bob laser comes on steady and the long range upward (Zenith) shooting laser beam is activated.

Self-leveling time is normally under ten seconds. After five minutes has elapsed, the downward shooting plumb-bob laser automatically shuts off to save battery power. If at a later time you want to check to see if you are over your point, just push the power button to **OFF**, then push again to **ON**. This will activate the plumb-bob laser for five more minutes.

SETTING UP

Note: Always set the Quad 1000 on the ground floor or lowest floor possible and leave it in that location for the duration of the job. Do not move the Quad 1000 up from floor to floor as the building progresses. This can create compounding errors.

USING THE TRIVET MOUNT: (This is the preferred method) It keeps the instrument low to the deck and closer to your reference point. Also, since the unit is only about five inches off the ground it won't be so vulnerable to getting knocked over like with a tripod.

- A) Attach the Quad 1000 to the trivet using the spring loaded 5/8 x 11 mounting bolt.
- B) Place the trivet over your reference point on the ground floor.
- C) Level the Quad 1000 bulls-eye bubble by using the adjustable legs on the trivet.
- D) Power up the Quad 1000 and allow it to self-level. The plumb-bob laser will blink until it has leveled.
- E) Once leveled, slide the trivet until the plumb laser is directly over your point. The instrument is now projecting a beam reference at Zenith.

TRIVET MOUNT

Carrying handles (2)

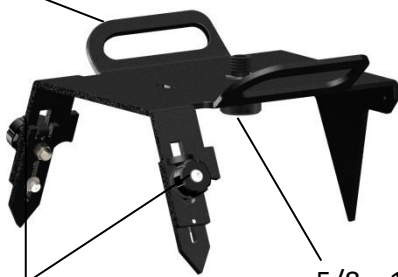

Adjustable leveling legs with knobs (2)

5/8 x 11 Threaded mounting screw



USING A TRIPOD:

(Standard Flat Head with 5/8 x 11 Attachment)

- A) Set the tripod over your point on the ground floor with the head fairly level.
- B) Attach the Quad to the tripod with the 5/8 x 11 bolt. (Snug only, do not over tighten)
- C) Power up the unit.
- D) Level the bulls-eye bubble on the Quad 1000 by adjusting the tripod legs up or down.
- E) Loosen the 5/8 x 11 attachment bolt and slide the Quad 1000 until the laser plumb-bob is directly over your point. Re-tighten attachment bolt to snug.

Tripod leg adjustment for leveling the bulls-eye bubble

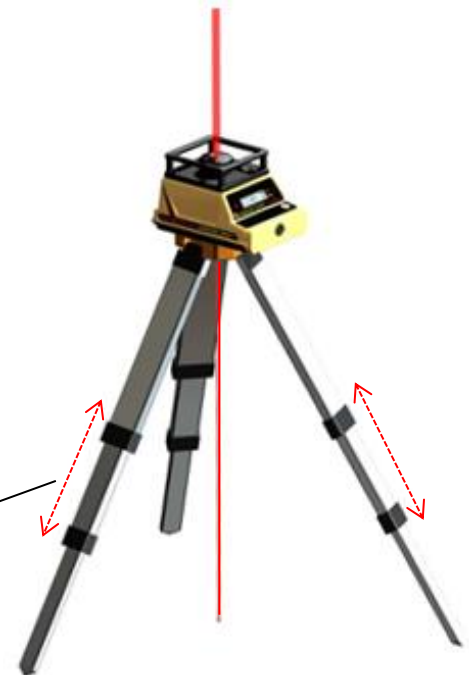

SETTING UP (CONTINUED)

PLACING THE QUAD 1000 DIRECTLY ON THE DECK / SLAB

(Flat / level surface ground floor)

- A) Using a pencil and a square, or the notched target provided, draw a line through and across the center of your reference point extending about 6 inches on either side of center. Next, draw a line through the center at 90 degrees from the first line at about the same 6 inch length from the reference point. You have created an X with the center intersection point being the center of the reference point.
- B) Set the Quad 1000 on the deck and adjust the unit so that two pencil lines are in line with the two centering notches on the sides of the Quad base, and one line is centered on the notch on the front of the Quad. The instrument is now directly over the reference point.
- C) Power up the Quad 1000.

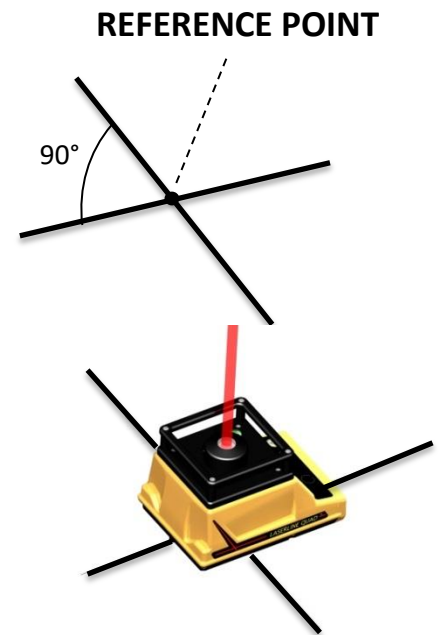

ALIGNMENT / TEMPLATE TARGETS (2ea.)

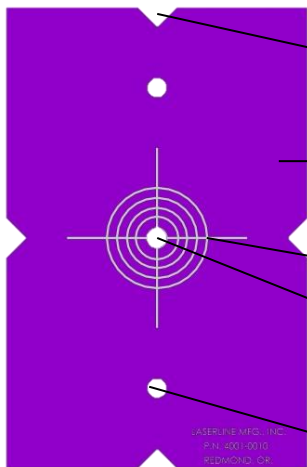

- A) They can be used as a centering template for floor/deck marking as described above. (4 template notches)
- B) The targets are made of a translucent material allowing the laser spot to be read from the opposite side that the laser spot is impacting the target face.
- C) The centering rings (bulls-eye target) make it easy to read the target and center the laser spot
- D) One target features a 1/4 inch hole through the target center that allows the center of the laser spot to pass through so that more than one target can be used at the same time.
- E) There are two mounting holes in each target to allow for custom mounting at the job site.

WARNING:

*Turn the laser **OFF** when centering up on the alignment target with an optical plummeted instrument. (Transferred points from floor to floor) Viewing the laser spot through an optical plummet can increase the chance of eye hazard.*



400 ft. / 122m



600 ft. / 183m



900 ft. / 274m

JOBSITE CALIBRATION CHECK

(Recommend performing calibration check once a week at minimum)

1. Using the trivet mount, tripod or deck / slab mount as shown in "Setting Up" get the Quad 1000 precisely over your reference point on the ground floor.
2. Place the target / template precisely centered on the laser spot at the highest point possible above the Quad 1000. (At least 100 feet if possible) Secure the target so it will not move.
3. Rotate the Quad 1000 180° and very precisely set it over the reference point.
4. Go back to the target and measure any change of the laser spot relative to the bulls-eye target.

Given the dynamics and movement of structures due to temperature, wind, loads etc., the target relation to the Quad 1000 laser may be moving and not providing a constant. This should definitely be taken into consideration so as a result, depending on conditions, you could be getting readings of $\pm 1/16$ or $\pm 1/8$ at the target per 100 vertical feet. If you are not comfortable or confident with the field calibration check, have it checked by your Dealer Service Department.

MAINTENANCE

The Quad 1000 requires no maintenance other than periodically cleaning the laser output lens. Use a soft cloth with Windex or alcohol.

****NOTE: Laser must be turned OFF when cleaning the lens!***

CERTIFICATION

USA EN/IEC 60824-1 2007 Class 3R

LASER SAFETY

Laser Light-Avoid Direct Eye Exposure

The maximum power output of this laser is less than 5mw. A laser safety kit is supplied with the Quad 1000 laser. The kit contains operator qualification cards and a sign that should be posted near the laser whenever it is in use. Observe the following rules:

- Never look directly into a laser beam or point the beam into the eyes of others. Set the laser at a height that prevents the beam from shining directly into people's eyes.
- DO NOT remove any warning signs from the laser.
- Only properly trained people are to use this product.
- Service to be performed only by factory trained personnel; unit contains no user serviceable parts.

LABELS
(Required for this product)



Explanatory and Warning Label-Hazard Symbol



Aperture Label

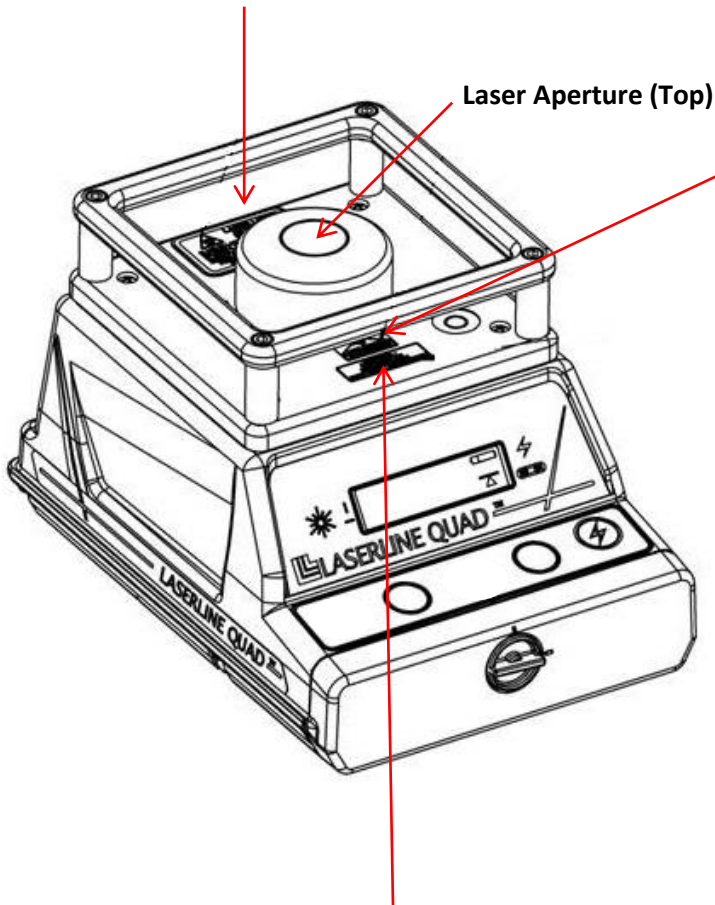

Laser Aperture (Top)

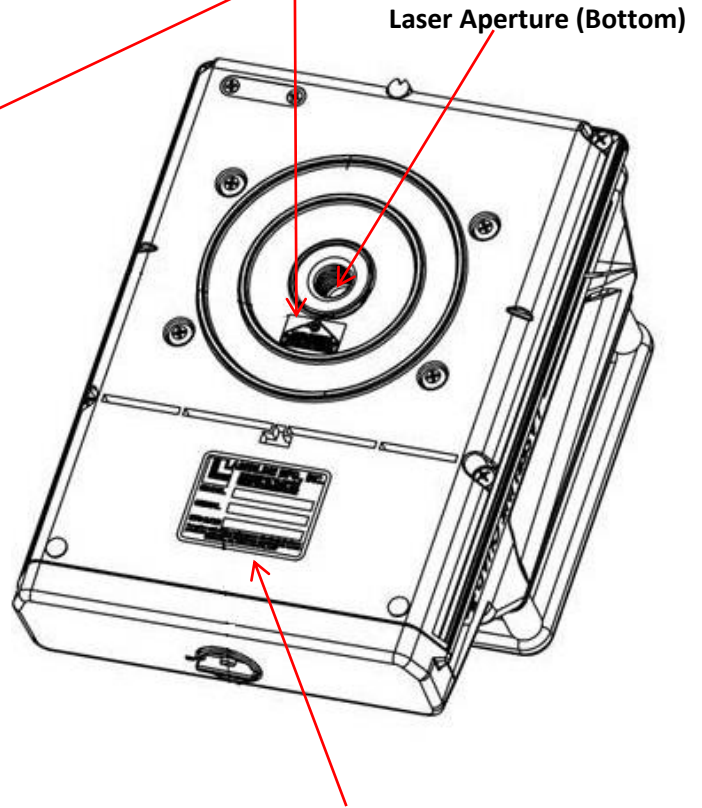

Laser Aperture (Bottom)



Non-Interlocked
Warning Label



Identification and Certification

QUAD 1000 SPECIFICATIONS

Laser

- Laser Wavelength: 635nm
- Laser Power: 4.5mw up / 1.0mw down
- USA EN/IEC 60824-1 2007 Class 3R
- International IEC 60825-1 2014 Class 3R
- U.S.A OSHA compliant: Meets all Federal and International standards
- Plumb Beam Down Accuracy / Range: 1 arc min. @ 15ft. (4.57m)
(For getting over a point)
- Plumb Beam UP Accuracy: ± 5 arc seconds / ($\pm 1/32$ per 100ft)
- Plumb Beam UP Range: 1,200 ft. (366m) (Depending on conditions)

Plumb Beam UP Spot Size: At Source (.500" / 12.7mm)

(Nominal) @300' / 91m (.375" / 9.52mm)
500' / 152m (.500" / 12.7mm)
700' / 213m (.687" / 17.46mm)
900' / 274m (.875" / 22.22mm)
1,200' / 366m (1.15" / 29.3mm)

Environment

- Operating Temperature: 0° to 122F (-18° to 50c)
- Storage Temperature: -4° to 158°F (-20° to 70°c)
- Dust and Water Sealed: To IP65 standards

Electronic

- Power Source: 4ea. D-cell alkaline batteries / 140 hrs. Battery life
(Depending on conditions)
- Self-Leveling: Electronic servo with variable temperature compensation
- Self-Leveling Range: $\pm 2^\circ$

Dimensions / Weight

- 6 ½ inch / 16.51cm = H
- 6 ½ inch / 16.51cm = W
- 9 ¼ inch / 23.5cm = L
- 7.25 lbs. (3.28k)= Weight

WARRANTY

This product is guaranteed against defects in materials and workmanship for both parts and labor, under normal working conditions for two years from the date of purchase, except as noted herein. LaserLine Mfg., Inc. liability under this warranty is limited to repairing or replacing any product returned to an authorized service center for that purpose. Any evidence of attempts to repair this unit by other than factory authorized personnel automatically voids the warranty. LaserLine Mfg., Inc. does not take liability for any damages caused by non-accuracy of this product. Before using the product always check for accuracy per the enclosed instructions in this manual.

Warning!

Under no circumstances, attempt to open or disassemble the Laser Housing. Doing so may cause exposure to potentially hazardous levels of laser light.

Caution: Use of controls or adjustments or performance of procedures other than those specified herein may result in hazardous laser light exposure.

Factory Service Center

LaserLine MFG., INC.
1810 S.E. First Street, Suite H,
Redmond, OR 97756
(P) 541-548-0882
(F) 541-548-0892
(Email) laserline@laserline.net

For all Warranty: Call Order Processing for RMA # at 541-548-0882. The Unit will be repaired and returned by prepaid freight.

All Non-Warranty Repairs:

Send to: LaserLine MFG., INC. at above address

Out of Warranty Repairs: 1 Year on replacement parts, 90 days on labor.