

Leica iCON iCR80



User Manual
Version 3.0
English

- when it has to be **right**

Leica
Geosystems

PART OF
HEXAGON

Introduction

Purchase

Congratulations on the purchase of the Leica iCON iCR80.



This manual contains important safety directions as well as instructions for setting up the product and operating it. Refer to **1 Safety Directions** for further information.

Read carefully through the User Manual before you switch on the product.

The content of this document is subject to change without prior notice. Ensure that the product is used in accordance with the latest version of this document.



The content of this document is subject to change without prior notice. Ensure that the product is used in accordance with the latest version of this document.

Updated versions are available for download at the following Internet address:
<https://myworld.leica-geosystems.com> > myProducts.

Product identification

The model and serial number of your product are indicated on the type label. Always refer to this information when contacting your agency or Leica Geosystems authorised service centre.

Trademarks

- Windows® is a registered trademark of Microsoft Corporation in the United States and other countries
- Bluetooth® is a registered trademark of Bluetooth SIG, Inc.
- SD Logo is a trademark of SD-3C, LLC.

All other trademarks are the property of their respective owners.

Validity of this manual

This manual applies to the Leica iCON iCR80.

Available documentation

Name	Description/Format		
iCR70/iCR80 Quick Guide	Provides an overview of the product together with technical data and safety directions. Intended as a quick reference guide.	✓	✓
iCR80 User Manual	All instructions required in order to operate the product to a basic level are contained in the User Manual. Provides an overview of the product together with technical data and safety directions.	-	✓
iCON build How-To Guide, iCON site How-To Guide	Overall comprehensive guide to the product and application functions. Included are detailed descriptions of special software/hardware settings and software/hardware functions intended for technical specialists.	-	✓

Refer to the following resources for all iCR80 documentation/software:

- the supplied data storage device
- <https://myworld.leica-geosystems.com>

**Leica Geosystems
address book**



On the last page of this manual, you can find the address of Leica Geosystems headquarters. For a list of regional contacts, please visit http://leica-geosystems.com/contact-us/sales_support.

<https://myworld.leica-geosystems.com> offers a wide range of services, information and training material.

With direct access to myWorld, you are able to access all relevant services whenever it is convenient for you.

The availability of services depends on the instrument model.

Service	Description
myProducts	Add all products that you and your company own and explore your world of Leica Geosystems: View detailed information on your products and update your products with the latest software and keep up-to-date with the latest documentation.
myService	View the current service status and full service history of your products in Leica Geosystems service centres. Access detailed information on the services performed and download your latest calibration certificates and service reports.
mySupport	Create new support requests for your products that will be answered by your local Leica Geosystems Support Team. View the complete history of your support requests and view detailed information on each request in case you want to refer to previous support requests.
myLearning	Welcome to the home of Leica Geosystems online learning! There are numerous online courses – available to all customers with products that have valid CCPs (Customer Care Packages).
myTrustedServices	Add your subscriptions and manage users for Leica Geosystems Trusted Services, the secure software services, that assist you to optimise your workflow and increase your efficiency.
mySmartNet	Add and view your HxGN SmartNet subscriptions and user information. HxGN SmartNet delivers high-precision and high-availability GNSS network correction services in real time. The HxGN SmartNet Global family offers Network RTK with RTK bridging and Precise Point Positioning (PPP) services. These services work exclusively with Leica Geosystems GS sensors, providing the highest accuracy. Combined, they ensure HxGN SmartNet coverage everywhere.
myDownloads	Downloads of software, manuals, tools, training material and news for Leica Geosystems products.

Table of Contents

PART 1 iCR80

1	Safety Directions	8
1.1	General Introduction	8
1.2	Definition of Use	9
1.3	Limits of Use	9
1.4	Responsibilities	10
1.5	Hazards of Use	10
1.6	Laser Classification	13
1.6.1	General	13
1.6.2	Distancer, Measurements with Reflectors	14
1.6.3	Distancer, Measurements without Reflectors	14
1.6.4	Red Laser Pointer	16
1.6.5	Automatic Target Aiming (ATRplus)	18
1.6.6	PowerSearch (PS)	18
1.6.7	Electronic Guide Light (EGL)	19
1.6.8	Laser Plummet	19
1.7	Electromagnetic Compatibility (EMC)	20
2	Description of the System	23
2.1	System Components	23
2.2	System Concept	25
2.2.1	Software Concept	25
2.2.2	Power Concept	26
2.2.3	Data Storage Concept	26
2.3	Container Contents	27
2.4	Instrument Components	28
3	User Interface	30
3.1	Keyboard	30
3.2	Operating Principles	31
4	Operation	33
4.1	Instrument Setup	33
4.2	Remote Control Setup	34
4.3	Holder and Clamp for Field Controller	35
4.4	Batteries	37
4.4.1	Operating Principles	37
4.4.2	Battery for the iCR Instrument	38
4.5	Power Functions	38
4.6	Working with the Memory Device	39
4.7	LED Indicators	41
4.8	Connecting to a Personal Computer	42
4.9	Guidelines for Correct Results	45
5	Check & Adjust	47
5.1	Overview	47
5.2	Preparation	48
5.3	Combined Adjustment (l, t, i, c and ATRplus)	49
5.4	Adjusting the Circular Level of the Instrument and Tribrach	51
5.5	Adjusting the Circular Level of the Prism Pole	52
5.6	Inspecting the Laser Plummet of the Instrument	52
5.7	Servicing the Tripod	53
6	TPS Specific Functionality within iCON site/iCON build	54
6.1	MC Application	54

6.2	Settings	54
7	Care and Transport	56
7.1	Transport	56
7.2	Storage	56
7.3	Cleaning and Drying	57
7.4	Maintenance	57
8	Technical Data	58
8.1	Angle Measurement	58
8.2	Distance Measurement with Reflectors	58
8.3	Distance Measurement without Reflectors	59
8.4	Automatic Target Aiming (ATRplus)	60
8.5	PowerSearch	61
8.6	LOC8 Theft Deterrence and Location Device (optional)	62
8.7	General Technical Data of the Product	62
8.8	Scale Correction	69
8.9	Reduction Formulas	72
8.10	Conformity to National Regulations	74
8.10.1	iCR80	74
8.10.2	CommunicationHandle	76
8.10.3	LOC8 Theft Deterrence and Location Device (optional)	77
8.10.4	Dangerous Goods Regulations	78
9	Software Licence Agreement/Warranty	80
PART 2 AutoPole		
10	Safety Directions	82
10.1	General Introduction	82
10.2	Definition of Use	83
10.3	Limits of Use	83
10.4	Responsibilities	84
10.5	Hazards of Use	84
10.6	Electromagnetic Compatibility (EMC)	88
11	System Components	90
12	Setting Up AutoPole	91
13	Battery for the AP20	93
14	Software Update	94
15	Working with the AutoPole	95
15.1	Overview	95
15.2	PoleHeight	95
15.3	Tilt Compensation	97
15.4	TargetID	98
16	LED Indicators	100
17	Care and Transport	101
17.1	Transport	101
17.2	Storage	101
17.3	Cleaning and Drying	101
18	Technical Data	103
18.1	PoleHeight	103
18.2	Tilt Compensation	103
18.3	TargetID	105
18.4	General Technical Data of the Product	106
18.5	Conformity to National Regulations	107

PART 1

iCR80

1 Safety Directions

1.1 General Introduction

Description

The following directions enable the person responsible for the product, and the person who actually uses the equipment, to anticipate and avoid operational hazards.

The person responsible for the product must ensure that all users understand these directions and adhere to them.

About warning messages





Warning messages are an essential part of the safety concept of the instrument. They appear wherever hazards or hazardous situations can occur.

Warning messages...

- make the user alert about direct and indirect hazards concerning the use of the product.
- contain general rules of behaviour.

For the users' safety, all safety instructions and safety messages shall be strictly observed and followed! Therefore, the manual must always be available to all persons performing any tasks described here.

DANGER, WARNING, CAUTION and **NOTICE** are standardised signal words for identifying levels of hazards and risks related to personal injury and property damage. For your safety, it is important to read and fully understand the following table with the different signal words and their definitions! Supplementary safety information symbols may be placed within a warning message as well as supplementary text.

Type	Description
 DANGER	Indicates an imminently hazardous situation which, if not avoided, will result in death or serious injury.
 WARNING	Indicates a potentially hazardous situation or an unintended use which, if not avoided, could result in death or serious injury.
 CAUTION	Indicates a potentially hazardous situation or an unintended use which, if not avoided, may result in minor or moderate injury.
NOTICE	Indicates a potentially hazardous situation or an unintended use which, if not avoided, may result in appreciable material, financial and environmental damage.
	Important paragraphs which must be adhered to in practice as they enable the product to be used in a technically correct and efficient manner.

Additional symbols



Warning against explosive material.



Warning against flammable substances.



Product must not be opened or modified or tampered with.



Indicates the temperature limits at which the product may be stored, transported or used.

1.2

Definition of Use

Intended use

- Measuring horizontal and vertical angles
- Measuring distances
- Recording measurements
- Automatic target search, recognition and tracking
- Visualising the aiming direction and vertical axis
- Remote control of product
- Data communication with external appliances
- Computing with software

Reasonably foreseeable misuse

- Use of the product without instruction
- Use outside of the intended use and limits
- Disabling of safety systems
- Removal of hazard notices
- Opening the product using tools, for example a screwdriver, unless this is permitted for certain functions
- Modification or conversion of the product
- Use after misappropriation
- Use of products with recognisable damage or defects
- Use with accessories from other manufacturers without the prior explicit approval of Leica Geosystems
- Inadequate safeguards at the working site
- Aiming directly into the sun

1.3

Limits of Use

Environment

Suitable for use in an atmosphere appropriate for permanent human habitation. Not suitable for use in aggressive or explosive environments.

WARNING

Working in hazardous areas or close to electrical installations or similar situations

Life Risk.

Precautions:

- ▶ Local safety authorities and safety experts must be contacted by the person responsible for the product before working in such conditions.

1.4

Responsibilities

Manufacturer of the product

Leica Geosystems AG, CH-9435 Heerbrugg, hereinafter referred to as Leica Geosystems, is responsible for supplying the product, including the User Manual and original accessories, in a safe condition.

Person responsible for the product

The person responsible for the product has the following duties:

- To understand the safety instructions on the product and the instructions in the User Manual
- To ensure that it is used in accordance with the instructions
- To be familiar with local regulations relating to safety and accident prevention
- To stop operating the system and inform Leica Geosystems immediately if the product and the application become unsafe
- To ensure that the national laws, regulations and conditions for the operation of the products are respected

1.5

Hazards of Use

NOTICE

Dropping, misusing, modifying, storing the product for long periods or transporting the product

Watch out for erroneous measurement results.

Precautions:

- ▶ Periodically carry out test measurements and perform the field adjustments indicated in the User Manual, particularly after the product has been subjected to abnormal use as well as before and after important measurements.

DANGER

Risk of electrocution

Because of the risk of electrocution, it is dangerous to use poles, levelling staffs and extensions in the vicinity of electrical installations such as power cables or electrical railways.

Precautions:

- ▶ Keep at a safe distance from electrical installations. If it is essential to work in this environment, first contact the safety authorities responsible for the electrical installations and follow their instructions.



NOTICE

Remote control of product

With the remote control of products, it is possible that extraneous targets will be picked out and measured.

Precautions:

- ▶ When measuring in remote control mode, always check your results for plausibility.

WARNING

Lightning strike

If the product is used with accessories, for example masts, staffs, poles, you may increase the risk of being struck by lightning.

Precautions:

- ▶ Do not use the product in a thunderstorm.
-

WARNING

Distraction/loss of attention

During dynamic applications, for example stakeout procedures, there is a danger of accidents occurring if the user does not pay attention to the environmental conditions around, for example obstacles, excavations or traffic.

Precautions:

- ▶ The person responsible for the product must make all users fully aware of the existing dangers.
-

WARNING

Inadequate securing of the working site

This can lead to dangerous situations, for example in traffic, on building sites and at industrial installations.

Precautions:

- ▶ Always ensure that the working site is adequately secured.
 - ▶ Adhere to the regulations governing safety, accident prevention and road traffic.
-

CAUTION

Pointing product toward the sun

Be careful when pointing the product toward the sun, because the telescope functions as a magnifying glass and can injure your eyes and/or cause damage inside the product.

Precautions:

- ▶ Do not point the product directly at the sun.
-

CAUTION

Not properly secured accessories

If the accessories used with the product are not properly secured and the product is subjected to mechanical shock, for example blows or falling, the product may be damaged or people can sustain injury.

Precautions:

- ▶ When setting up the product, make sure that the accessories are correctly adapted, fitted, secured, and locked in position.
 - ▶ Avoid subjecting the product to mechanical stress.
-

 **WARNING**

Inappropriate mechanical influences to batteries

During the transport, shipping or disposal of batteries it is possible for inappropriate mechanical influences to constitute a fire hazard.

Precautions:

- ▶ Before shipping the product or disposing it, discharge the batteries by the product until they are flat.
- ▶ When transporting or shipping batteries, the person in charge of the product must ensure that the applicable national and international rules and regulations are observed.
- ▶ Before transportation or shipping, contact your local passenger or freight transport company.

 **WARNING**

Exposure of batteries to high mechanical stress, high ambient temperatures or immersion into fluids

This can cause leakage, fire or explosion of the batteries.

Precautions:

- ▶ Protect the batteries from mechanical influences and high ambient temperatures. Do not drop or immerse batteries into fluids.

 **WARNING**

Short circuit of battery terminals

If battery terminals are short circuited e.g. by coming in contact with jewellery, keys, metallised paper or other metals, the battery can overheat and cause injury or fire, for example by storing or transporting in pockets.

Precautions:

- ▶ Make sure that the battery terminals do not come into contact with metallic/conductive objects.

WARNING

Improper disposal

If the product is improperly disposed of, the following can happen:

- If polymer parts are burnt, poisonous gases are produced which may impair health.
- If batteries are damaged or are heated strongly, they can explode and cause poisoning, burning, corrosion or environmental contamination.
- By disposing of the product irresponsibly you may enable unauthorised persons to use it in contravention of the regulations, exposing themselves and third parties to the risk of severe injury and rendering the environment liable to contamination.

Precautions:



The product must not be disposed with household waste. Dispose of the product appropriately in accordance with the national regulations in force in your country. Always prevent access to the product by unauthorised personnel.

Product-specific treatment and waste management information can be received from your Leica Geosystems distributor.

WARNING

Improperly repaired equipment

Risk of injuries to users and equipment destruction due to lack of repair knowledge.

Precautions:

- ▶ Only authorised Leica Geosystems Service Centres are entitled to repair these products.

1.6



Laser Classification

1.6.1

General

General

The following chapters provide instructions and training information about laser safety according to international standard IEC 60825-1 (2014-05) and technical report IEC TR 60825-14 (2004-02). The information enables the person responsible for the product and the person who actually uses the equipment, to anticipate and avoid operational hazards.

-  According to IEC TR 60825-14 (2004-02), products classified as laser class 1, class 2 and class 3R do not require:
 - laser safety officer involvement
 - protective clothes and eyewear
 - special warning signs in the laser working areaif used and operated as defined in this User Manual due to the low eye hazard level.
-  National laws and local regulations could impose more stringent instructions for the safe use of lasers than IEC 60825-1 (2014-05) and IEC TR 60825-14 (2004-02).

1.6.2

Distancer, Measurements with Reflectors

General

The EDM module built into the product produces a visible laser beam which emerges from the telescope objective.

The laser product described in this section is classified as laser class 1 in accordance with:

- IEC 60825-1 (2014-05): "Safety of laser products"

These products are safe under reasonably foreseeable conditions of operation and are not harmful to the eyes provided that the products are used and maintained in accordance with this User Manual.

Description	Value
Wavelength	658 nm
Pulse duration	800 ps
Pulse repetition frequency (PRF)	100 MHz
Maximum average radiant power	0.33 mW
Beam divergance	1.5 mrad × 3 mrad

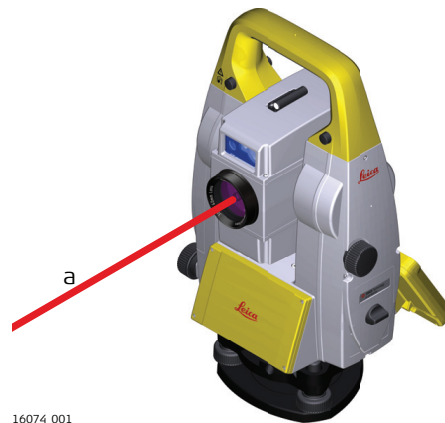

a Laser beam

1.6.3

Distancer, Measurements without Reflectors

General

The EDM module built into the product produces a visible laser beam which emerges from the telescope objective.

The laser product described in this section is classified as laser class 3R in accordance with:

- IEC 60825-1 (2014-05): "Safety of laser products"

Direct intrabeam viewing may be hazardous (low eye hazard level), in particular for deliberate ocular exposure. The beam may cause dazzle, flash-blindness and after-images, particularly under low ambient light conditions. The risk of injury for laser class 3R products is limited because of:

- a) unintentional exposure would rarely reflect worst case conditions of (e.g.) beam alignment with the pupil, worst case accommodation,
- b) inherent safety margin in the maximum permissible exposure to laser radiation (MPE)
- c) natural aversion behaviour for exposure to bright light for the case of visible radiation.

Description	Value (R30/R1000)
Wavelength	658 nm
Maximum average radiant power	4.8 mW
Pulse duration	800 ps
Pulse repetition frequency (PRF)	100 MHz
Beam divergence	0.2 mrad × 0.3 mrad
NOHD (Nominal Ocular Hazard Distance) @ 0.25 s	44 m/144 ft

⚠ CAUTION

Class 3R laser products

From a safety perspective, class 3R laser products should be treated as potentially hazardous.

Precautions:

- ▶ Prevent direct eye exposure to the beam.
- ▶ Do not direct the beam at other people.

⚠ CAUTION

Reflected beams aimed at reflecting surfaces

Potential hazards are not only related to direct beams but also to reflected beams aimed at reflecting surfaces such as prisms, windows, mirrors, metallic surfaces, etc.

Precautions:

- ▶ Do not aim at areas that are essentially reflective, such as a mirror, or which could emit unwanted reflections.
- ▶ Do not look through or beside the optical sight at prisms or reflecting objects when the laser is switched on, in laser pointer or distance measurement mode. Aiming at prisms is only permitted when looking through the telescope.

Labelling

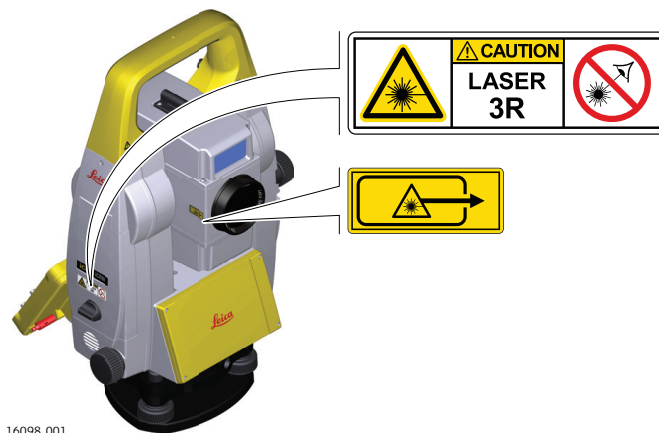

16098.001

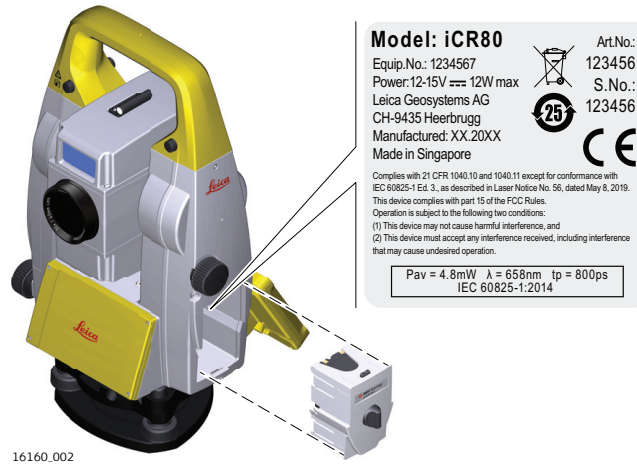

1.6.4

Red Laser Pointer

General

The laser pointer built into the product produces a visible red laser beam which emerges from the telescope objective.

The laser product described in this section is classified as laser class 3R in accordance with:

- IEC 60825-1 (2014-05): "Safety of laser products"

Direct intrabeam viewing may be hazardous (low eye hazard level), in particular for deliberate ocular exposure. The beam may cause dazzle, flash-blindness and after-images, particularly under low ambient light conditions. The risk of injury for laser class 3R products is limited because of:

- unintentional exposure would rarely reflect worst case conditions of (e.g.) beam alignment with the pupil, worst case accommodation,
- inherent safety margin in the maximum permissible exposure to laser radiation (MPE)
- natural aversion behaviour for exposure to bright light for the case of visible radiation.

Description	Value (R30/R1000)
Wavelength	658 nm
Maximum average radiant power	4.8 mW
Pulse duration	800 ps
Pulse repetition frequency (PRF)	100 MHz
Beam divergence	0.2 mrad × 0.3 mrad
NOHD (Nominal Ocular Hazard Distance) @ 0.25 s	44 m/144 ft

⚠ CAUTION

Class 3R laser products

From a safety perspective, class 3R laser products should be treated as potentially hazardous.

Precautions:

- ▶ Prevent direct eye exposure to the beam.
- ▶ Do not direct the beam at other people.

⚠ CAUTION

Reflected beams aimed at reflecting surfaces

Potential hazards are not only related to direct beams but also to reflected beams aimed at reflecting surfaces such as prisms, windows, mirrors, metallic surfaces, etc.

Precautions:

- ▶ Do not aim at areas that are essentially reflective, such as a mirror, or which could emit unwanted reflections.
- ▶ Do not look through or beside the optical sight at prisms or reflecting objects when the laser is switched on, in laser pointer or distance measurement mode. Aiming at prisms is only permitted when looking through the telescope.

Labelling

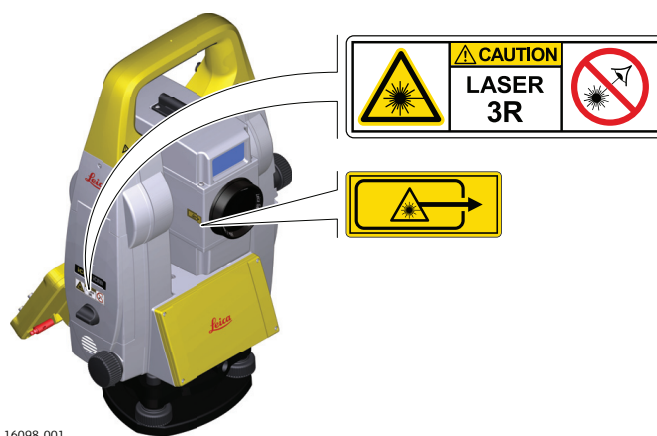

1.6.5

Automatic Target Aiming (ATRplus)

General

The Automatic Target Aiming built into the product produces an invisible laser beam which emerges from the telescope objective.

The laser product described in this section is classified as laser class 1 in accordance with:

- IEC 60825-1 (2014-05): "Safety of laser products"

These products are safe under reasonably foreseeable conditions of operation and are not harmful to the eyes provided that the products are used and maintained in accordance with this User Manual.

Description	Value
Wavelength	785 nm
Maximum radiant peak power per pulse	10 mW
Pulse duration	≤ 15 ms
Pulse repetition frequency (PRF)	≤ 213 Hz
Beam divergence	25 mrad

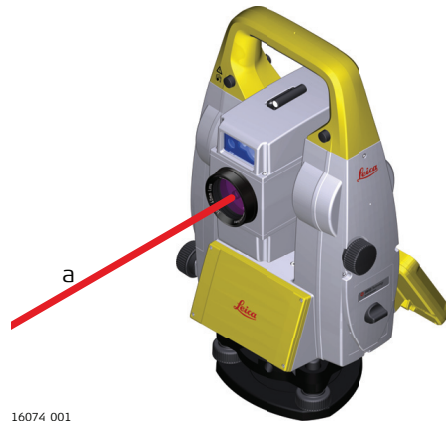

a Laser beam

1.6.6

PowerSearch (PS)

General

The PowerSearch built into the product produces an invisible laser beam which emerges from the front side of the telescope.

The laser product described in this section is classified as laser class 1 in accordance with:

- IEC 60825-1 (2014-05): "Safety of laser products"

These products are safe under reasonably foreseeable conditions of operation and are not harmful to the eyes provided that the products are used and maintained in accordance with this User Manual.

Description	Value
Wavelength	850 nm
Maximum average radiant power	11 mW
Pulse duration	20 ns, 40 ns
Pulse repetition frequency (PRF)	24.4 kHz

Description	Value
Beam divergence	0.4 mrad × 700 mrad

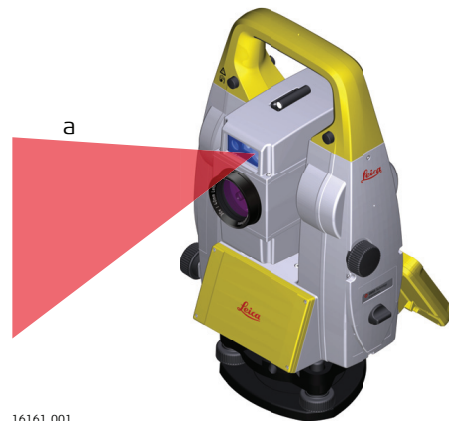

16161.001

a Laser beam

1.6.7

Electronic Guide Light (EGL)

General

The Electronic Guide Light built into the product produces a visible LED beam which emerges from the front side of the telescope.



The product described in this section, is excluded from the scope of IEC 60825-1 (2014-05): "Safety of laser products".

The product described in this section, is classified as exempt group in accordance with IEC 62471 (2006-07) and does not pose any hazard provided that the product is used and maintained in accordance with this user manual.

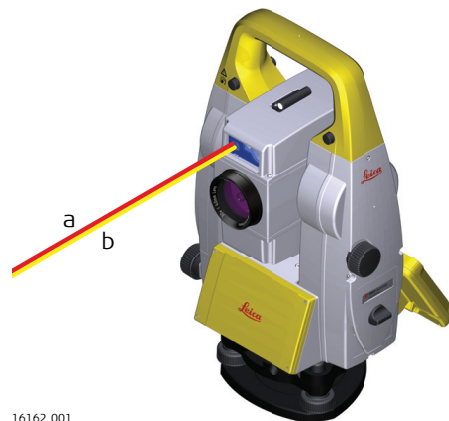

16162.001

a LED beam red
b LED beam yellow

1.6.8

Laser Plummet

General

The laser plummet built into the product produces a visible red laser beam which emerges from the bottom of the product.

The laser product described in this section is classified as laser class 2 in accordance with:

- IEC 60825-1 (2014-05): "Safety of laser products"

These products are safe for momentary exposures but can be hazardous for deliberate staring into the beam. The beam may cause dazzle, flash-blindness and after-images, particularly under low ambient light conditions.

Description	Value
Wavelength	640 nm
Maximum average radiant power	0.95 mW
Pulse duration- cw (continuous wave)	10 ms
Pulse repetition frequency (PRF)	1 kHz
Beam divergence	<1.5 mrad

⚠ CAUTION

Class 2 laser product

From a safety perspective, class 2 laser products are not inherently safe for the eyes.

Precautions:

- ▶ Avoid staring into the beam or viewing it through optical instruments.
- ▶ Avoid pointing the beam at other people or at animals.

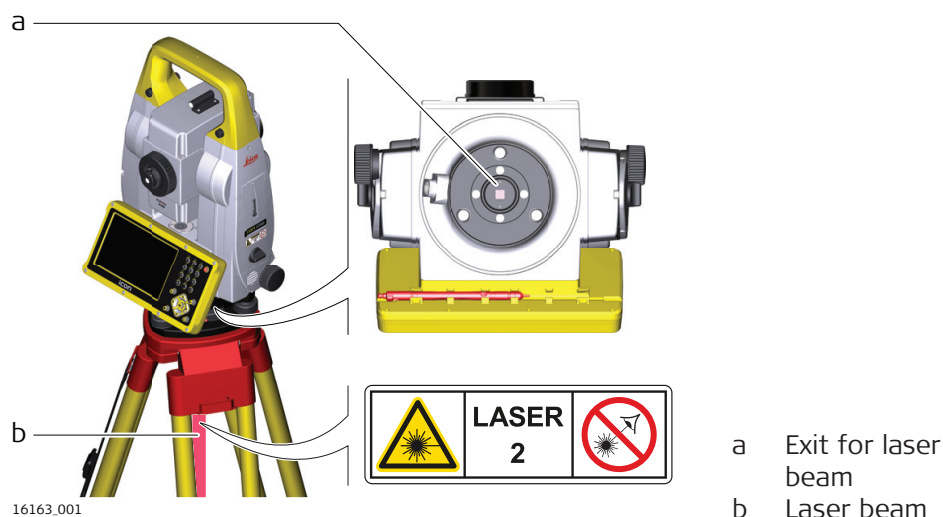

1.7

Electromagnetic Compatibility (EMC)

Description

The term Electromagnetic Compatibility is taken to mean the capability of the product to function smoothly in an environment where electromagnetic radiation and electrostatic discharges are present, and without causing electromagnetic disturbances to other equipment.

 **CAUTION**

Electromagnetic radiation

Electromagnetic radiation can cause disturbances in other equipment.

Precautions:

- ▶ Although the product meets the strict regulations and standards which are in force in this respect, Leica Geosystems cannot completely exclude the possibility that other equipment may be disturbed.

 **CAUTION**

Use of the product with accessories from other manufacturers. For example, field computers, personal computers or other electronic equipment, non-standard cables or external batteries

This may cause disturbances in other equipment.

Precautions:

- ▶ Use only the equipment and accessories recommended by Leica Geosystems.
- ▶ When combined with the product, other accessories must meet the strict requirements stipulated by the guidelines and standards.
- ▶ When using computers, two-way radios or other electronic equipment, pay attention to the information about electromagnetic compatibility provided by the manufacturer.

 **CAUTION**

Intense electromagnetic radiation. For example, near radio transmitters, transponders, two-way radios or diesel generators

Although the product meets the strict regulations and standards which are in force in this respect, Leica Geosystems cannot completely exclude the possibility that the function of the product may be disturbed in such an electromagnetic environment.

Precautions:

- ▶ Check the plausibility of results obtained under these conditions.

 **CAUTION**

Electromagnetic radiation due to improper connection of cables

If the product is operated with connecting cables, attached at only one of their two ends, the permitted level of electromagnetic radiation may be exceeded and the correct functioning of other products may be impaired. For example, external supply cables or interface cables.

Precautions:

- ▶ While the product is in use, connecting cables, for example product to external battery or product to computer, must be connected at both ends.

 **WARNING**

Use of product with radio or digital cellular phone devices

Electromagnetic fields can cause disturbances in other equipment, installations, medical devices, for example pacemakers or hearing aids, and aircrafts. Electromagnetic fields can also affect humans and animals.

Precautions:

- ▶ Although the product meets the strict regulations and standards which are in force in this respect, Leica cannot completely exclude the possibility that other equipment can be disturbed or that humans or animals can be affected.
 - ▶ Do not operate the product with radio or digital cellular phone devices in the vicinity of filling stations or chemical installations, or in other areas where an explosion hazard exists.
 - ▶ Do not operate the product with radio or digital cellular phone devices near medical equipment.
 - ▶ Do not operate the product with radio or digital cellular phone devices in aircrafts.
 - ▶ Do not operate the product with radio or digital cellular phone devices for long periods with the product immediately next to your body.
-

2

Description of the System

2.1

System Components

Main Components



Component	Description
iCR80 instrument	<ul style="list-style-type: none">• a total station for measuring, calculating and capturing data.• with a range of accuracy classes.• combined with the multi-purpose construction field controller to conduct remote control surveys.
CC80 field controller	A multipurpose field controller allowing the remote control of the iCR80 via Bluetooth.
Infinity	The office software including a series of help programs which support working with Leica instruments.
AutoPole (AP)	A product group with active sensor components which can be attached to AP Reflector Poles. The AP can communicate with total station, field controller or tablet.
AP Reflector Pole	A dedicated group of reflector poles with passive sensing elements inside, capable to carry an AutoPole. Without AutoPole, an AP Reflector Pole can also be used as conventional pole.
Infinity	The office software including a series of help programs which support working with Leica instruments.

Terms and abbreviations

The following terms and abbreviations can be found in this manual:

Term	Description
EDM	Electronic Distance Measurement EDM refers to the laser distancer incorporated into the instrument which enables distance measurement. Two measuring modes are available: <ul style="list-style-type: none">• Prism mode. This mode refers to the ability to measure distances to prisms.• Reflectorless mode. This mode refers to the ability to measure distances without prisms.

Term	Description
PinPoint	PinPoint refers to the Reflectorless EDM technology which enables an increased measuring range with a smaller laser spot size. Two options are available: R30 and R1000.
EGL	Electronic Guide Light An EGL fitted to an instrument assists with prism targeting. It consists of two differently coloured flashing lights located in the instrument telescope housing. The person holding the prism can align themselves into the line of sight of the instrument.
ATRplus	Automatic Target Aiming. ATRplus refers to the instrument sensor which enables the automatic target aiming and locking.
PowerSearch	PowerSearch (PS) refers to the instrument sensor which enables the automatic rapid finding of a prism.
Communication-Handle CCD6/ CCD18	The CCD6/CCD18 CommunicationHandle is an instrument carry handle with an integrated radio modem with attached antenna.
Communication side cover	Communication side cover with integrated Bluetooth, SD card slot and USB port is standard for a iCR80 instrument.
Machine Control Application	Enables optimal communication between iCR80 and 3D Machine Control Systems. To carry out machine calibration and alignment routines when used with Leica 3D Paving Systems.
Setup Pilot	A method to carry out the setup of the iCR80 to a number of existing control points in a fully automated way.
Cube Search	A method to optimise the prism search. Creates a cube-shaped search window around the position where the prism was lost. Dynamically, the search window is updated and adjusted in size depending on the distance between prism and iCR80.
Target Snap	A prism search method. Snaps to the desired prism by ignoring other prisms, which are known from the database.

Features of iCR80

- Angle measurement
- Distance measurement to prism
- Distance measurement to any surface (reflectorless)
- Motorised
- Automatic Target Aiming
- PowerSearch (PS)
- RS232, USB and SD card interface
- Bluetooth
- Internal Flash Memory (2 GB)
- Hotshoe interface for CommunicationHandle
- Electronic Guide Light (EGL)
- WLAN

2.2 System Concept

2.2.1 Software Concept





Description

All instruments use the same software concept.



Software

Software type	Description
System software	This software comprises the central functions of the instrument. It is also referred to as firmware.
iCON Field software	It is recommended to control the instrument with Leica Geosystems field software. Refer to the respective software manual for more information.

Software update

-  Uploading software can take some time. Ensure that the battery is at least 75% full before beginning the upload, and do not remove the battery during the upload process.
-  The iCON software is stored in the flash RAM of the iCON iCR80.
- 1. Download the most recent iCON iCR80 firmware file from <https://myworld.leica-geosystems.com>.
- 2. Insert an SD card or USB stick into the computer.
- 3. Copy the iCON iCR80 firmware file into the \SYSTEM folder on the storage device. If no \SYSTEM folder is available, then create the folder first.
- 4. Take the storage device out of the computer and insert it into the instrument.
- 5. Start the iCON iCR80 and the iCON software.
- 6. Tap on **System**.
- 7. Tap on **FW Update**.
- 8. Select the firmware file.
- 9. Tap  to start the firmware update.
-  *A message will appear when the upload is complete.*

Licence activation

-  Licences are key codes to enable software functions and applications which run on the instrument. You can order new licences on myWorld or by contacting your local service partner.
- 1. Store the licence key file (*.key) on an SD card or a USB memory stick.
 -  Alternatively have a printout of a licence key at hand.
- 2. Insert the SD card or USB memory stick into the iCR80. Refer to [4.6 Working with the Memory Device](#).
- 3. Turn on the iCR80.
- 4. In the iCON software:
Select **System > Add Licences**.
- 5. Upload the licence key file or type in the licence code manually.

To upload a licence key file:

- Tap on **Load Key From** to define the storage location of the licence key file.
- Select the licence key file.
- Tap ✓ to start the activation process.

To type in a licence key:

- Tap into the input field to activate the virtual keyboard.
- Type in the licence key from the printout.
- Tap ✓ to start the activation process.

A pop-up informs you about the licence activation status. Confirm the message.



If the software maintenance licence has expired: Contact your local service partner to update the software on the instrument.



If the licence activation fails: Contact your local service partner or create a support request on myWorld.

2.2.2**Power Concept****General**

Use the batteries, chargers and accessories recommended by Leica Geosystems to ensure the correct functionality of the instrument.

Power options

- Internally by GEB222 battery, OR
- Externally by GEV52 cable and GEB373 battery.



If an external power supply is connected and the internal battery is inserted, then the external power is used.

2.2.3**Data Storage Concept****Description**

Data is stored on a memory device. The memory device can be an SD card or internal memory. For data transfer an USB stick can also be used.

Memory device

Device	Description
SD card	All instruments have an SD card slot fitted as standard. An SD card can be inserted and removed. Available capacity: 1 GB and 8 GB.
USB stick	All instruments have a USB port fitted as standard.
Internal memory	All instruments have an internal memory fitted as standard. Available capacity: 2 GB.



While other SD cards/USB sticks can be used, Leica Geosystems recommends to only use Leica SD cards/USB sticks and is not responsible for data loss or any other error that can occur while using a non-Leica SD card/USB stick.



Unplugging connecting cables or removing the SD card or USB stick during the measurement can cause loss of data. Only remove the SD card or USB stick or unplug connecting cables when the iCR instrument is switched off.

Transfer data

Data can be transferred in various ways.



SD cards can directly be used in an OMNI drive as supplied by Leica Geosystems. Other PC card drives can require an adaptor.

2.3

Container contents for instrument and accessories

Container Contents

Bottom part

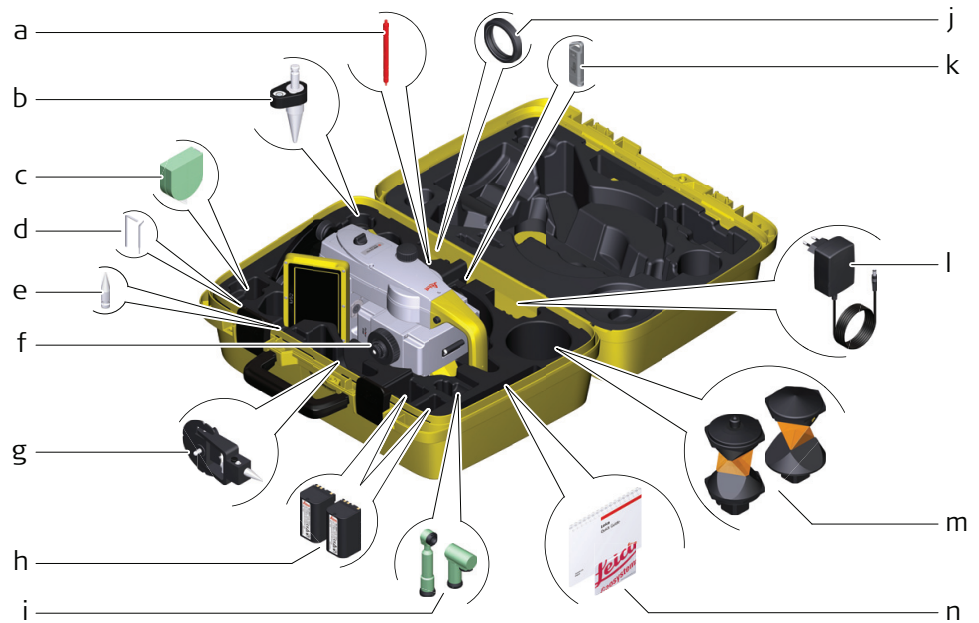

16553_001

- a Stylus
- b GLS14 mini pole
- c GHM007 Instrument height meter
- d Allen key and adjustment tool
- e Tip for GMP101 mini prism
- f Instrument with tribrach and standard handle or Communication-Handle
- g GMP101 mini prism
- h GEB222 batteries
- i GFZ3 or GOK6 diagonal eyepiece
- j Counterweight for diagonal eyepiece
- k MS1, 1 GB USB memory stick
- l GEV192 AC power supply for battery charger
- m GRZ4 or GRZ122 prism
- n Manuals and USB documentation card

Top part

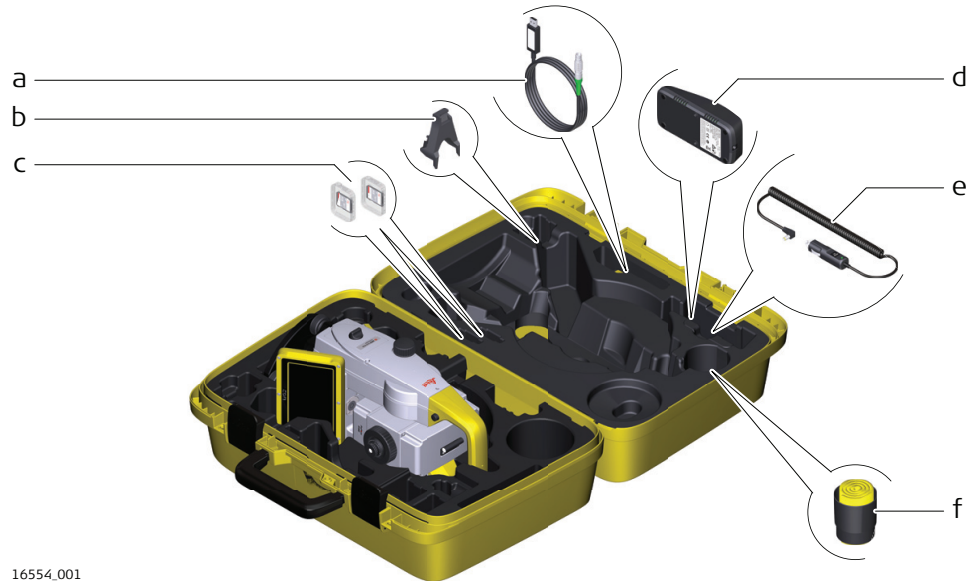

16554.001

- a Cables
- b GHT196 tribrach bracket for height meter
- c SD cards and covers
- d GKL311 battery charger
- e Car adapter power plug for battery charger (stored under battery charger)
- f Protective cover for instrument, sunshade for objective lens and cleaning cloth

2.4

Instrument Components

iCR80 instrument components part 1 of 2



16067.001

- a Carry handle
- b Optical sight
- c Telescope, integrating EDM, ATRplus, EGL, PS
- d EGL flashing diode - yellow and red
- e PowerSearch, transmitter
- f PowerSearch, receiver
- g Coaxial optics for angle and distance measurement, and exit port of visible laser beam for distance measurements
- h Compartment for SD Card and USB stick
- i Loudspeaker
- j Horizontal drive
- k Tribrach footscrew
- l Second keyboard (optional)

**iCR80 instru-
ment components
part 2 of 2**



- a Vertical drive
- b Focusing ring
- c Interchangeable eyepiece
- d Circular level
- e Battery compartment
- f Touch screen
- g Stylus for touch screen
- h Keyboard

**Communication side
cover**

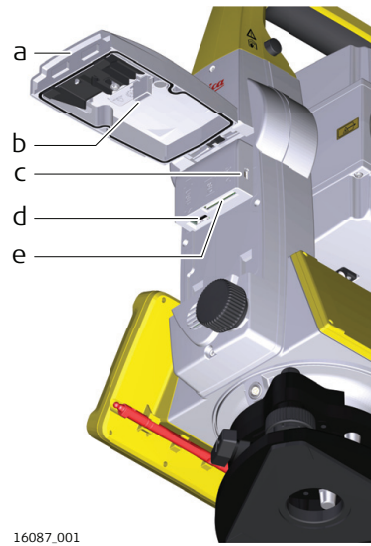

- a Compartment lid
- b USB stick cap storage
- c USB device port (mini AB OTG)
- d USB host port for USB stick
- e SD card port

**Instrument compon-
ents for remote mode**



- a CommunicationHandle
- b Communication side cover

3 User Interface

3.1 Keyboard



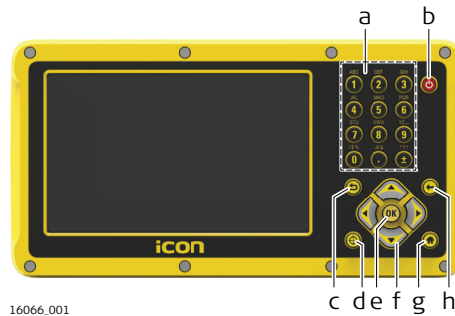







iCR80 keyboard



16066.001

- a Alphanumeric keys
- b ON/OFF
- c Back or Cancel
- d Measure
- e OK
- f Arrow keys
- g Home
- h Backspace

Keys

Key	Function
Alphanumeric keys 	To type letters and numbers.
ON/OFF 	If the instrument is already off: Turns on the instrument when held for 2 s. If the instrument is already on: Displays the "Exit/Shutdown" screen when held for 2 s.
Back or Cancel 	To leave the current screen without storing any changes. To close an info message.
Backspace 	Deletes the last character in an entry field.
Measure 	 This functionality is available if a measurement application is active on the field controller. The functionality of the key can vary depending on the configuration of the measure bar (Measure or Meas+Rec). Starts the measurement in the currently selected measurement mode .
Lock 	 This functionality is available if the instrument is connected to a field controller and if no measurement application is active on the field controller. Starts a prism search and locks onto prism.
Home 	Switches to the iCON Main Menu.
Arrow keys 	Allow moving the focus on the screen or paging through a list.
OK 	Selects the highlighted line and leads to the next logical menu / dialog. Starts the edit mode for editable fields. Opens a selectable list.

3.2 Operating Principles

Keyboard and touch screen

The user interface is operated on the touch screen. In some applications, the keyboard can be used instead. Refer to iCON build How to guide and iCON site How to guide for information.

Home menu elements

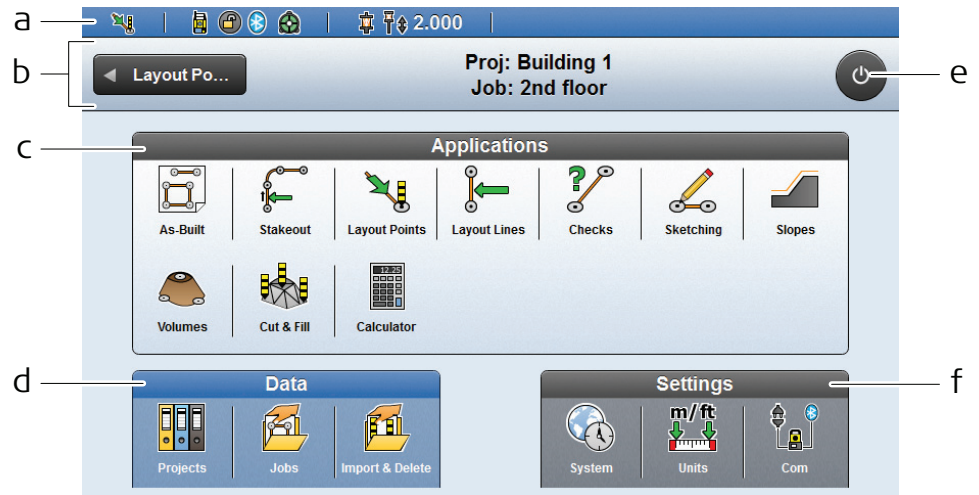

16582_001_en

- | | | | |
|---|-----------------------|---|--------------------|
| a | Status bar | d | Data container |
| b | Title bar | e | Power key |
| c | Application container | f | Settings container |

Map screen elements

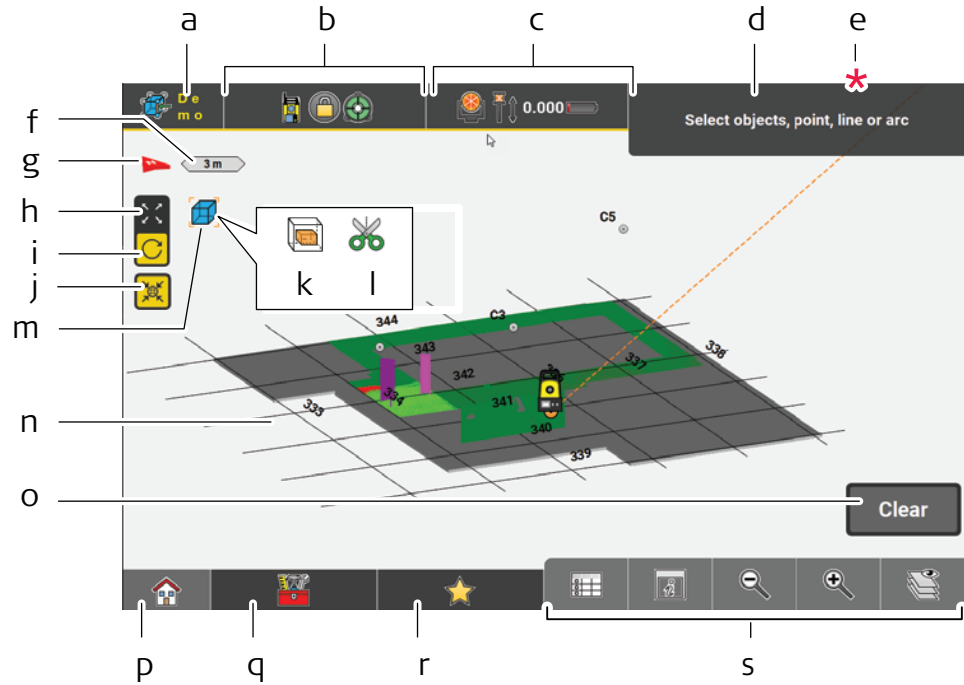

006804.007

- | | | | |
|---|---------------------------------------------------|---|-----------------------------------------|
| a | Application key | k | Limit Box indicator |
| b | Status 1 | l | Clipping Filter ¹⁾ indicator |
| c | Status 2 | m | Isolation mode indicator |
| d | Information bar | n | Main map area |
| e | Warning bar (only displayed if there is an issue) | o | Measure bar |
| f | Scale bar | p | Home key |
| g | North indicator | q | Toolbox |
| h | Button for panning mode | r | Favourites |
| i | Button for rotation mode (3D) | s | Map handler |
| j | Button for auto-centring the map view | | |

¹⁾ Clipping Filter not supported for onboard

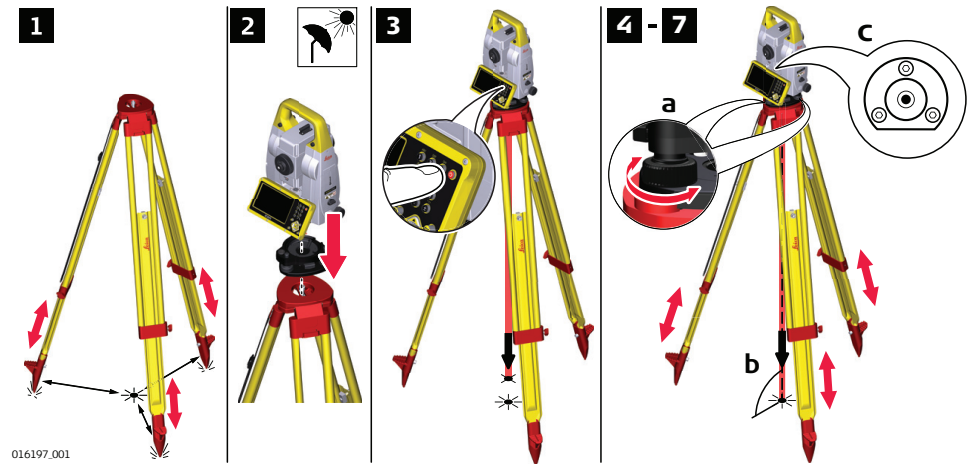
Instrument setup
step-by-step

1. Extend the tripod legs to allow for a comfortable working posture. Position the tripod above the marked ground point, centring it as good as possible. Ensure that the tripod plate is roughly horizontal.

2. Fasten the tribrach and instrument onto the tripod.
 -  Shield the instrument from direct sunlight and avoid uneven temperatures around the instrument.

3. Turn on the instrument.
To activate the laser plummet, display the Compensator screen:
 - Select **Devices** from the Home Menu.
 - Tap the arrow button to the right of the device name.
 - Tap **Compensator**.

4. Use the tribrach footscrews (a) to centre the plummet above the ground point (b).

5. Adjust the tripod legs to level the circular level (c).

6. By using the electronic level, turn the tribrach footscrews (a) to level the instrument precisely.

7. Centre the instrument precisely over the ground point (b) by shifting the tribrach on the tripod plate.

8. Repeat steps 6. and 7. until the required accuracy is achieved.

4.2

Remote Control Setup

Attaching the CommunicationHandle step-by-step

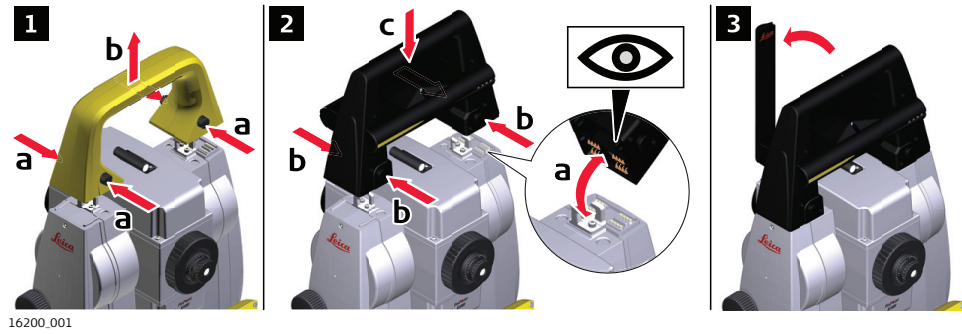

Refer to [4.1 Instrument Setup](#) for the initial instrument setup onto a tripod.

1. To remove the instrument carry handle: Press and hold the four unlock push buttons and lift off the handle.
2. To install the CommunicationHandle, first make sure that the interface connection on the lower part of the handle is on the same side as the Communication side cover. Then press and hold the four unlock push buttons and attach the handle.



Ensure that there is a tight fit with the instrument after releasing the push buttons. If no connection can be found, re-check that handle is seated firmly.

3. Swing the antenna of the CommunicationHandle into an upright position.



Refer to field software manual for additional information.

Setup for remote control with CommunicationHandle

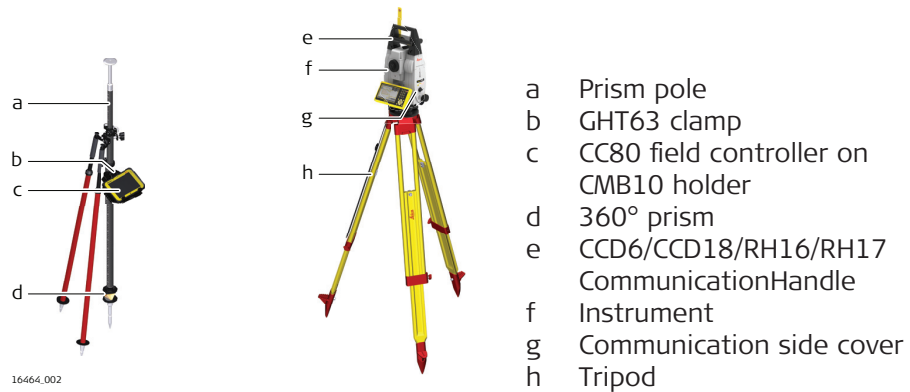

- a Prism pole
- b GHT63 clamp
- c CC80 field controller on CMB10 holder
- d 360° prism
- e CCD6/CCD18/RH16/RH17 CommunicationHandle
- f Instrument
- g Communication side cover
- h Tripod

4.3

Holder and Clamp for Field Controller

Holder for CC80

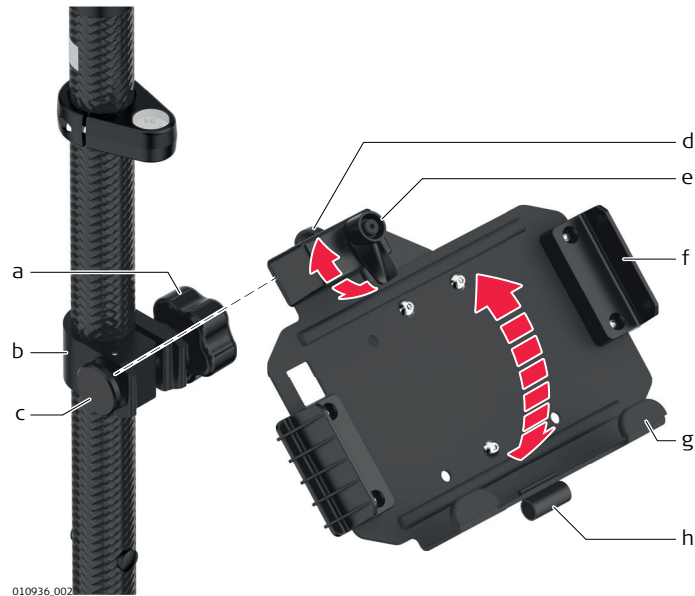

Clamp

- a Tightening screw
- b Pole clamp
- c Clamping bolt

Holder

- d Mounting arm
- e Locking lever
- f Mounting brackets (side)
- g Mounting brackets (bottom)
- h Holder for stylus

Fixing the CC80 tablet to a pole step-by-step

 For an aluminium pole, fit the plastic sleeve to the pole clamp.

1. Insert the pole into the clamp hole.
2. Attach the holder to the clamp using the clamp bolt.
3. Adjust the angle and the height of the holder on the pole to a comfortable position.
4. Tighten the clamp with the clamp bolt.
5. Before placing the CC80 tablet onto the mounting plate, ensure that the locking lever is set to the unlocked position (see illustration).



6. Lower the bottom side of the tablet and slide it into the bottom mounting brackets of the holder.



- After placing the tablet onto the mounting plate, set the locking lever to the locked position (see illustration).

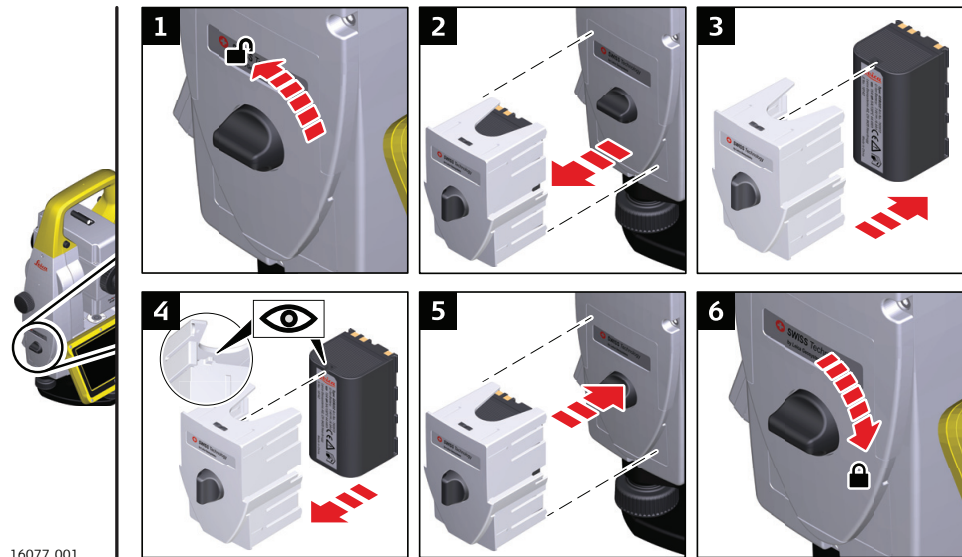

- Face the instrument so that the vertical drive screw is on the left. The battery compartment is below the vertical drive. Turn the knob to the vertical position, opening the lid of the battery compartment.
- Pull out the battery housing.
- Pull the battery out of the battery housing.
-  At the top of the battery is a notch which corresponds to the inner surface of the battery housing. This notch helps you to place the battery correctly.
Place the battery into the battery housing, ensuring that the contacts are facing outward. Click the battery into position.
- Place the battery housing into the battery compartment. Push the battery housing in until it fits completely into the battery compartment.
- Turn the knob to lock the battery compartment. Ensure that the knob is returned to its original horizontal position.

Detaching the tablet from the holder/pole step-by-step

1. Set the locking lever of the holder to the unlocked position.



2. Lift the top side of the tablet and slide the tablet to the top and out of the holder.



4.4

Batteries

4.4.1

Operating Principles

First-time use/ charging batteries

- The battery must be charged before using it the first time, because it is delivered with an energy content as low as possible or might be in sleep mode.
- The permissible temperature range for charging is from 0 °C to +40 °C / +32 °F to +104 °F. For optimal charging, we recommend charging the batteries at a low ambient temperature of +10 °C to +20 °C / +50 °F to +68 °F if possible
- It is normal for the battery to become warm during charging. Using the chargers recommended by Leica Geosystems, it is not possible to charge the battery once the temperature is too high
- For new batteries or batteries that have been stored for a long time (> three months), it is effectual to make only one charge/discharge cycle
- For Li-Ion batteries, a single discharging and charging cycle is sufficient. We recommend carrying out the process when the battery capacity indicated on the charger or on a Leica Geosystems product deviates significantly from the actual battery capacity available.

Operation/discharging

- The batteries can be operated from -20 °C to +55 °C / -4 °F to +131 °F.
- Low operating temperatures reduce the capacity that can be drawn; high operating temperatures reduce the service life of the battery.

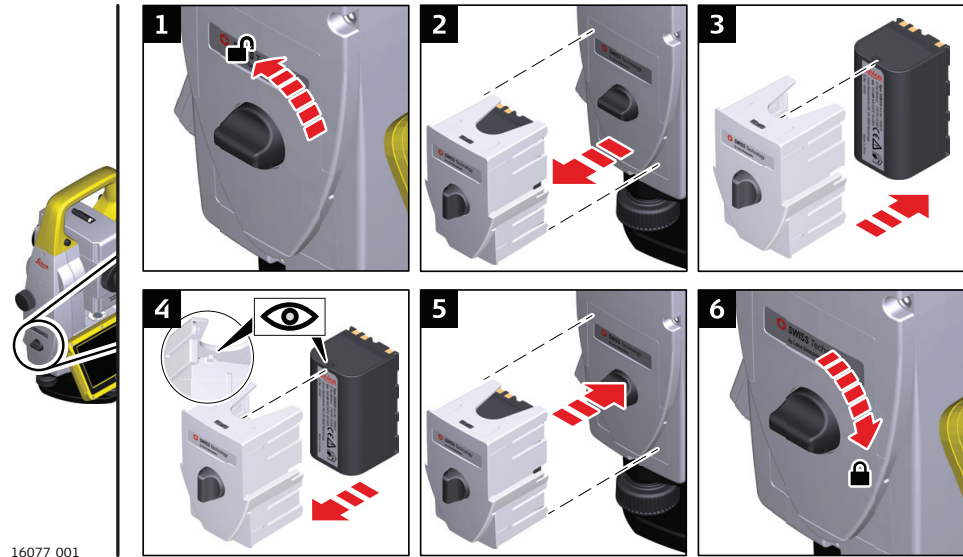
Change battery
step-by-step

16077.001

1. Face the instrument so that the vertical drive screw is on the left. The battery compartment is below the vertical drive. Turn the knob to the vertical position, opening the lid of the battery compartment.
2. Pull out the battery housing.
3. Pull the battery out of the battery housing.
4.  At the top of the battery is a notch which corresponds to the inner surface of the battery housing. This notch helps you to place the battery correctly.
Place the battery into the battery housing, ensuring that the contacts are facing outward. Click the battery into position.
5. Place the battery housing into the battery compartment. Push the battery housing in until it fits completely into the battery compartment.
6. Turn the knob to lock the battery compartment. Ensure that the knob is returned to its original horizontal position.

4.5

Power Functions

Power functions

Option	Key	Description
Turn on	ON/OFF	Press and hold for 2 s.  The instrument must have a power supply.

Option	Key	Description
Turn off	ON/OFF	<p>Press and hold for 2 s. The "Exit/Shutdown" screen is displayed. Select Exit/Shutdown.</p> <p> For instruments set up in permanent installations with external power sources, for example monitoring, ensure external power remains available until the instrument has successfully completed the power down process.</p>
Reset	ON/OFF	<p>Press and hold for 2 s. The "Exit/Shutdown" screen is displayed. Choose one of the available reset options.</p>
Hard shutdown	ON/OFF	<p>Press and hold for more than 8 s:</p> <ul style="list-style-type: none"> • After 2 s, the "Exit/Shutdown" screen is displayed. • Continue to press and hold until instrument shuts down.

4.6

Working with the Memory Device



- Keep the card dry.
- Use it only within the specified temperature range.
- Do not bend the card.
- Protect the card from direct impacts.



Failure to follow these instructions could result in data loss and/or permanent damage to the card.

Insert and remove an SD card step-by-step

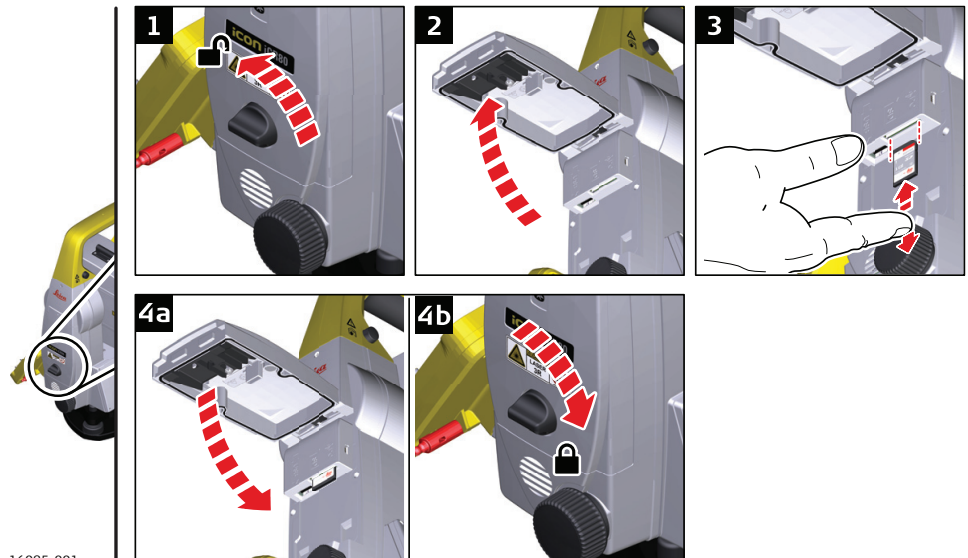

16085_001



The SD card is inserted into a slot inside the Communication side cover of the instrument.

1. Turn the knob on the Communication side cover to the vertical position to unlock the communication compartment.

2. Open the lid of the communication compartment to access the communication ports.

3.
 - To insert the SD card, slide it firmly into the SD slot until it clicks into position.
 - To remove the SD card, gently press on the top of the card to release it from the slot.
 -  The card must be held with the contacts at the top and facing toward the instrument.
 -  Do not force the card into the slot.

4. Close the lid and turn the knob to the horizontal position to lock the communication compartment.

Insert and remove a USB stick step-by-step

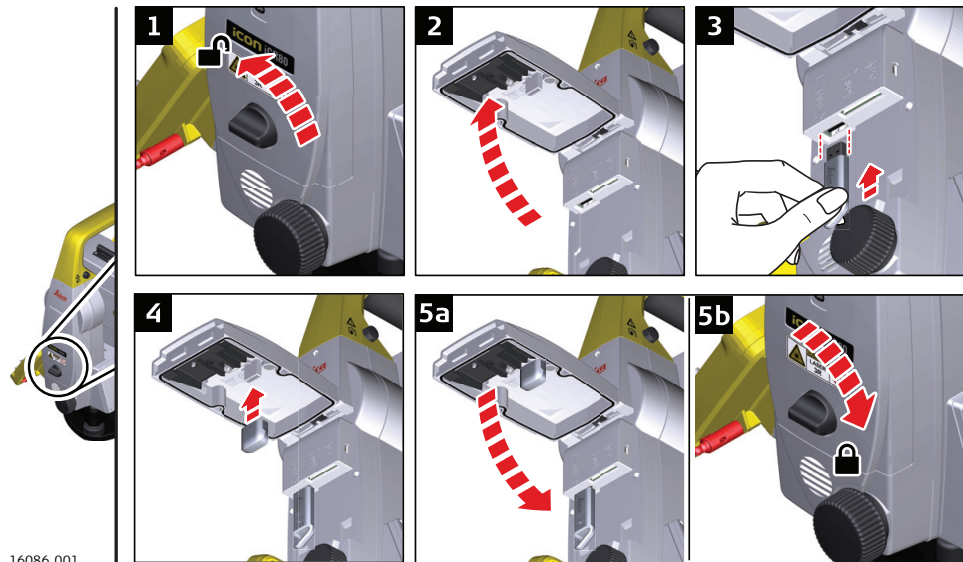

16086.001

-  The USB stick is inserted into the USB host port inside the Communication side cover of the instrument.
-
1. Turn the knob on the Communication side cover to the vertical position to unlock the communication compartment.

 2. Open the lid of the communication compartment to access the communication ports.

 3. Slide the USB stick with the Leica logo facing you firmly into the USB host port until it clicks into position.
 -  Do not force the USB stick into the port. To remove the USB stick, slide the USB stick out of the port.

 4. If desired, store the lid of the USB stick on the underside of the compartment lid.

 5. Close the lid and turn the knob to the horizontal position to lock the compartment.

4.7

LED Indicators

LED indicators on Communication-Handle

Description

The CommunicationHandle has Light Emitting Diode (LED) indicators. They indicate the basic CommunicationHandle status.

Diagram of the LED Indicators



- a Power LED
- b Link LED
- c Data Transfer LED
- d Mode LED

Description of the LED Indicators

LED	LED Status	Description
Power LED	off	Power is off.
	green	Power is on.
Link LED	off	No radio link to field controller.
	red	Radio link to field controller.
Data Transfer LED	off	No data transfer to/from field controller.
	green or green flashing	Data transfer to/from field controller.
Mode LED	off	Data mode.
	red	Configuration mode.

LED indicators on Communication-Handle CCD18

Description

The RadioHandle has Light Emitting Diode (LED) indicators. They indicate the basic RadioHandle status.

Diagram of the LED Indicators



- a CC Link LED
- b CC Data Transfer LED
- c AP Link LED
- d AP Data Transfer LED

Description of the LED Indicators

IF the	is	THEN
CC Link LED and AP Link LED	off	power is off.
CC Link LED	green	no radio link to field controller.
	blue	radio link to field controller.
CC Data Transfer LED	off	no data transfer to/from field controller.
	green or green flashing	data transfer to/from field controller.
	red	configuration mode.
AP Link LED	green	no radio link to AutoPole.
	blue	radio link to AutoPole.
AP Data Transfer LED	off	no data transfer to/from AutoPole.
	green or green flashing	data transfer to/from AutoPole.
	red	synchronisation mode.

4.8

Connecting to a Personal Computer

Description

Windows Mobile Device Center for PC with Windows 7/Windows 8/Windows 10 operating system is the synchronization software for Windows mobile-based pocket PC. WMDC enables a PC and a Windows mobile-based pocket PC to communicate.

Leica USB drivers support Windows 7, Windows 8 (8.1) and Windows 10 operating systems.

Cables

Leica USB drivers support:

Name	Description
GEV223	USB data cable, 1.8 m, connects instrument to Mini-USB to USB
GEV234	USB data cable, 1.65 m, connects CC to iCG or CC to PC (USB)
GEV261	Y-cable, 1.8 m, connects instrument to PC – battery

Uninstalling the previous drivers

 Skip the following steps if you have never installed Leica USB drivers before.

If older drivers were previously installed on the PC, follow the instructions to uninstall the drivers prior the installation of the new drivers.

1. Connect your instrument to the PC via cable.
2. On your PC, select to **Control Panel > Device Manager**.
3. In **Network Adapters**, right-click on **Remote NDIS based LGS...**
4. Click on **Uninstall**.

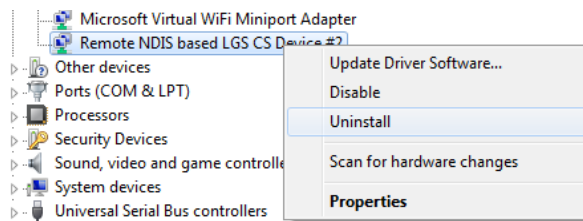

5. Set **Delete the driver...** as checked. Press **OK**.

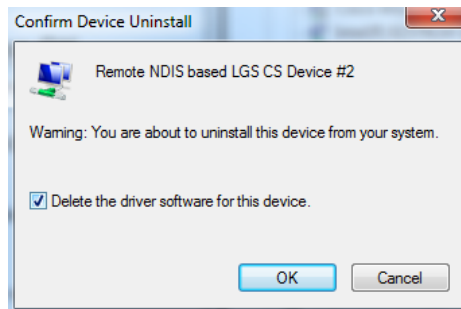

Install Leica USB drivers

1. Start the PC.
2. Run the **Setup_Leica_USB_XXbit.exe** to install the drivers necessary for Leica devices. Depending on the version (32bit or 64bit) of the operating system on your PC, you have to select between the three setup files following:
 - Setup_Leica_USB_32bit.exe
 - Setup_Leica_USB_64bit.exe
 - Setup_Leica_USB_64bit_itanium.exe

 To check the version of your operating system, go to **Control Panel > System > System type**.

 The setup requires administrative privileges.

 The setup has to be run only once for all Leica devices.

3. The **Welcome to InstallShield Wizard for Leica GS, TS/TM/MS, CS and GR USB drivers** window appears.

 Ensure that all Leica devices are disconnected from your PC before you continue!

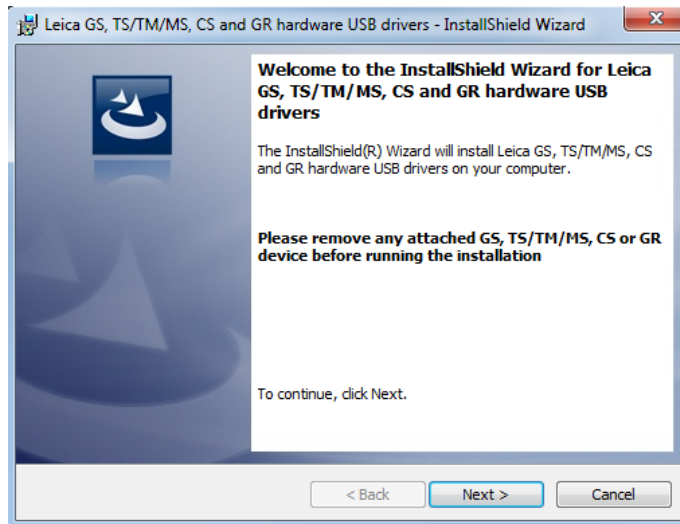

4. Click **Next>**.

5. The **Ready to Install the Program** window appears.

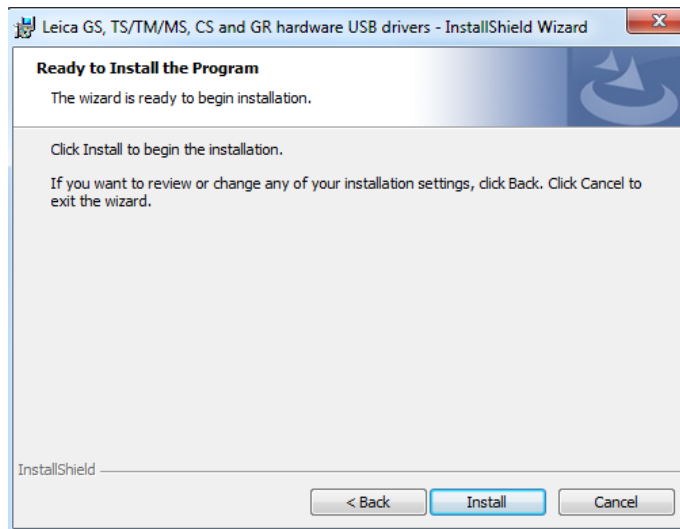

6. Click **Install**. The drivers will be installed on your PC.

7. The **InstallShield Wizard Completed** window appears.

8. Click **Finish** to exit the wizard.

Connect to PC via USB cable step-by-step

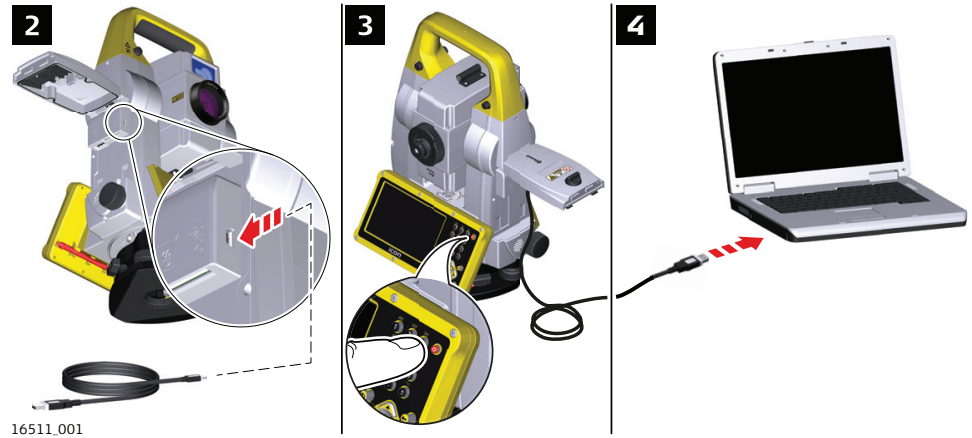

1. Start the PC.
2. Plug the cable into the instrument.
3. Turn on the instrument.
4. Plug the cable into the USB port of the PC.
5. Press the Windows Start button at the bottom left corner of the screen.
6. Type the IP address of the device into the search field.
\\192.168.254.3\
7. Press **Enter**.
A file browser opens. You can now browse within the folders on the instrument.

4.9

Guidelines for Correct Results

Distance measurement

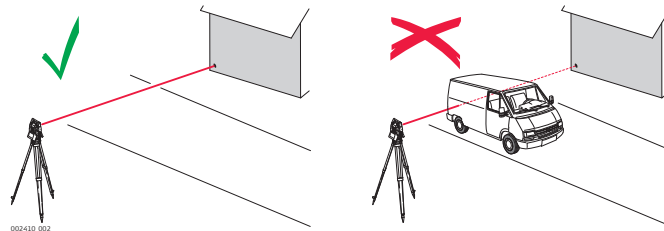

When measurements are being made using the red laser EDM, the results can be influenced by objects passing between the EDM and the intended target surface. This occurs because reflectorless measurements are made to the first surface returning sufficient energy to allow the measurement to take place. For example, if the intended target surface is the surface of a building, but a vehicle passes between the EDM and the target surface as the measurement is triggered, the measurement may be made to the side of the vehicle. The result is the distance to the vehicle, not to the surface of the building.



Very short distances can also be measured reflectorless in Prism mode to well reflecting natural targets. The distances are corrected with the additive constant defined for the active reflector.



Accurate measurements to prisms should be made in prism mode.



When a distance measurement is triggered, the EDM measures to the object which is in the beam path at that moment. If a temporary obstruction, for example a passing vehicle, heavy rain, fog or snow is between the instrument and the point to be measured, the EDM may measure to the obstruction.



Do not measure with two instruments to the same target simultaneously to avoid getting mixed return signals.

ATRplus/Lock

Instruments equipped with an ATRplus sensor permit automatic angle and distance measurements to prisms. The prism is sighted with the optical sight. After initiating a distance measurement, the instrument sights the prism centre automatically. Vertical and horizontal angles and the distance are measured to the centre of the prism. The lock mode enables the instrument to follow a moving prism.



As with all other instrument errors, the collimation error of the automatic aiming must be redetermined periodically. Refer to [5 Check & Adjust](#) about checking and adjusting instruments.



When a measurement is triggered while the prism is still moving, distance and angle measurements may not be made for the same position and coordinates may vary.



If the prism location is changed too quickly, the target may be lost. Make sure that the speed does not exceed the figure given in the technical data.

5

Check & Adjust

5.1

Overview

Description

Leica Geosystems instruments are manufactured, assembled and adjusted to the best possible quality. Quick temperature changes, shock or stress can cause deviations and decrease the instrument accuracy. It is therefore recommended to check and adjust the instrument from time to time. This check and adjust can be done in the field by running through specific measurement procedures. The procedures are guided and must be followed carefully and precisely as described in the following chapters. Some other instrument errors and mechanical parts can be adjusted mechanically.

Electronic adjustment

The following instrument errors can be checked and adjusted electronically:

Instrument error	Description
l, t	Compensator longitudinal and transversal index errors
i	Vertical index error, related to the standing axis
c	Horizontal collimation error, also called line of sight error
a	Tilting axis error
ATRplus	ATRplus zero point error for Hz and V

If the compensator and the horizontal corrections are activated in the instrument configuration, every angle measured in the daily work is corrected automatically. Check whether the tilt correction and the horizontal correction are turned on.

The results are displayed as errors but used with the opposite sign as corrections when applied to measurements.

Mechanical adjustment

The following instrument parts can be adjusted mechanically:

- Circular level on instrument and tribrach
- Optical plummet - option on tribrach
- Allen screws on tripod

Precise measurements

To get precise measurements in the daily work, it is important:

- To check and adjust the instrument from time to time.
- To take high precision measurements during the check and adjust procedures.
- To measure targets in two faces. Some of the instrument errors are eliminated by averaging the angles from both faces.



During the manufacturing process, the instrument errors are carefully determined and set to zero. As mentioned above, these errors can change and it is highly recommended to redetermine them in the following situations:

- Before the first use
- Before every high precision survey
- After rough or long transportation
- After long working periods
- After long storage periods
- If the temperature difference between current environment and the temperature at the last calibration is more than 20 °C

Summary of errors to be adjusted electronically

Instrument error	Effects Hz	Effects V	Elimination with two face measurement	Automatically corrected with proper adjustment
c - Line of sight error	✓	-	✓	✓
a - Tilting axis error	✓	-	✓	✓
l - Compensator index error	-	✓	✓	✓
t - Compensator index error	✓	-	✓	✓
i - Vertical index error	-	✓	✓	✓
ATRplus Collimation error	✓	✓	-	✓

5.2

Preparation

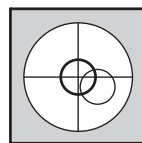

Before determining the instrument errors, the instrument has to be levelled using the electronic level. The tribrach, the tripod and the underground should be stable and secure from vibrations or other disturbances.



The instrument should be protected from direct sunlight to avoid thermal warming. It is also recommended to avoid strong heat shimmer and air turbulence. The best conditions are early in the morning or with overcast sky.



Before starting to work, the instrument has to become acclimatised to the ambient temperature. Take at least 15 minutes into account or approximately 2 minutes per °C of temperature difference from storage to working environment.



Even after adjustment of the ATRplus, the crosshairs may not be positioned exactly on the centre of the prism after an ATRplus measurement has been completed. This outcome is a normal effect. To speed up the ATRplus measurement, the telescope is normally not positioned exactly on the centre of

the prism. These small deviations ATRplus offsets, are calculated individually for each measurement and corrected electronically. This means that the horizontal and vertical angles are corrected twice: first by the determined ATRplus errors for Hz and V, and then by the individual small deviations of the current aiming.

Next step

- **Adjusting a combination of instrument errors**
Refer to [5.3 Combined Adjustment \(l, t, i, c and ATRplus\)](#).
- **Adjusting the circular level**
Refer to [5.4 Adjusting the Circular Level of the Instrument and Tribrach](#).
- **Adjusting the laser/optical plummet**
Refer to [5.6 Inspecting the Laser Plummet of the Instrument](#).
- **Adjusting the tripod**
Refer to [5.7 Servicing the Tripod](#).

5.3 Combined Adjustment (l, t, i, c and ATRplus)

Description

The combined adjustment procedure determines the following instrument errors in one process:

Instrument error	Description
l, t	Compensator longitudinal and transversal index errors
i	Vertical index error, related to the standing axis
c	Horizontal collimation error, also called line of sight error
ATRplus Hz	ATRplus zero point error for horizontal angle option
ATRplus V	ATRplus zero point error for vertical angle option



Combined adjustment procedure step-by-step

The following description explains the most common settings:

 It is recommended to use a clean Leica circular prism as target. Do not use a 360° prism.

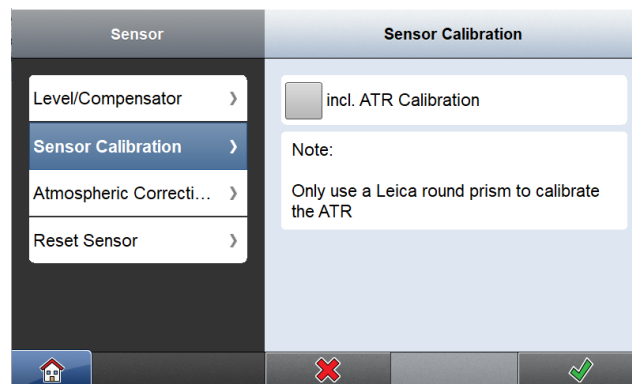
1.
 - Connect the device with the Instrument.
 - Select **Sensor** from the Home Menu.
 - Select your instrument and tap the arrow.
2. Select **Sensor Calibration**.



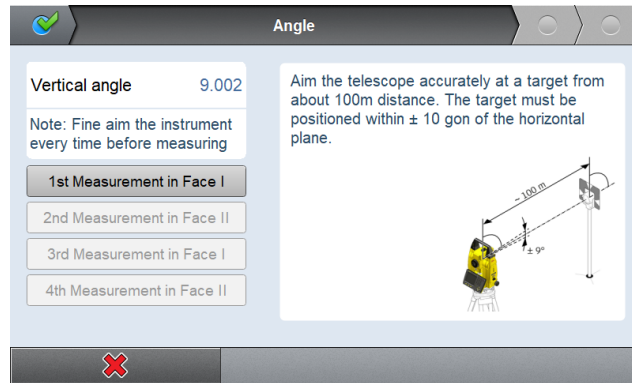

- Select the **incl. ATR Calibration** option if you like to calibrate the ATR.
 - To start calibration, tap .
-
- 3.
- Aim the telescope accurately at a target at about 100 m distant. The target must be positioned within $\pm 9^\circ/\pm 10$ gon of the horizontal plane.
 - Start the procedure in face I.
 - Motorised instruments change automatically to face I.
 - Press the measurement keys to measure and to continue to the next step.
- Tap  in the wizard to get to the next page.
-

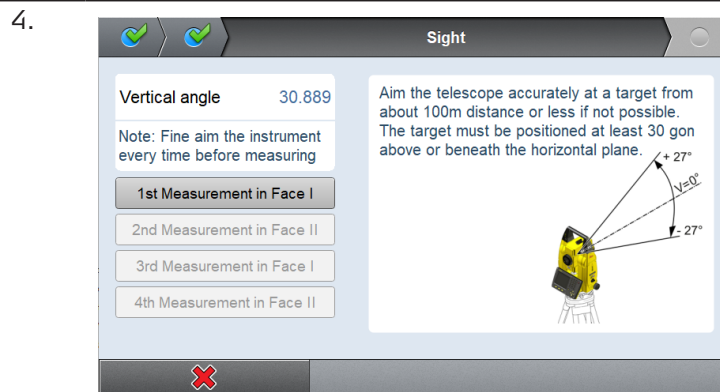

 The fine aiming has to be performed manually in both faces.



- Aim the telescope accurately at a target at about 100 m distant or less if not possible. The target must be positioned at least $27^\circ/30$ gon above or beneath the horizontal plane.
 - Start the procedure in face I.
 - Motorised instruments change automatically to the other face.
 - Press the measurement keys to measure and to continue to the next step.
- Tap  in the wizard to get to the next page.
-

 The fine aiming has to be performed manually in both faces.

5. **Adjustment Accuracy**
- After pressing the last  in the wizard the results are shown and stored to the instrument.
-

Result	
Compensator longitudinal index error	
Old: 0.0000	New: 0.0000
Compensator transversal index error	
Old: 0.0000	New: 0.0000
Vertical index error	
Old: 0.0000	New: 0.0000
Tilt axis error	
Old: -0.0007	New: -0.0145
Line of sight error	
Old: -0.0001	New: 0.0020

6. Tap  to get back to the **Devices** page.

5.4

Adjusting the Circular Level of the Instrument and Tribrach

Adjusting the circular level step-by-step

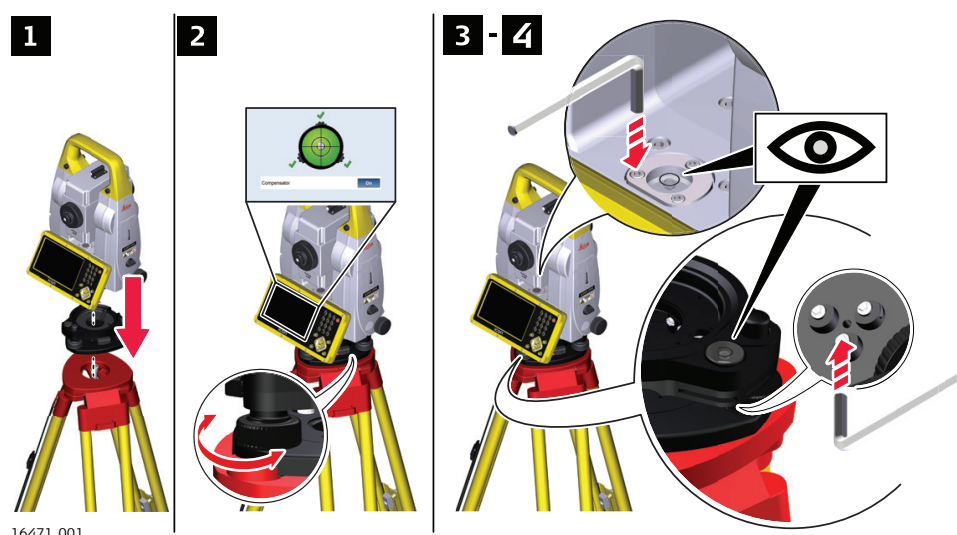

1. Place and secure the instrument into the tribrach and onto a tripod.
2. Turn on the instrument. Using the tribrach footscrews, level the instrument with the electronic level.



Electronic level:

- Select **Devices** from the Home Menu.
- Tap the arrow button to the right of the device name.
- To display the electronic level, tap **Compensator**.

3. Check the position of the circular level on the instrument and tribrach.



If both circular levels are centred, no adjustments are necessary.

4. If one or both circular levels are not centred, adjust as follows:
Instrument: If it extends beyond the circle, use the supplied allen key to centre it with the adjustment screws. Turn the instrument by 200 gon (180°). Repeat the adjustment procedure if the circular level does not stay centred.
Tribrach: If it extends beyond the circle, use the supplied allen key to centre it with the adjustment screws.

- ☞ After the adjustments, all adjusting screws must have the same tightening tension and no adjusting screw should be loose.

5.5

Adjusting the Circular Level of the Prism Pole

Adjusting the circular level step-by-step

1. Suspend a plumb line.
2. Use a pole bipod, to align the prism pole parallel to the plumb line.
3. Check the position of the circular level on the prism pole.
4.
 - a If the circular level is centred, no adjustment is necessary.
 - b If the circular level is not centred, use an allen key to centre it with the adjustment screws.

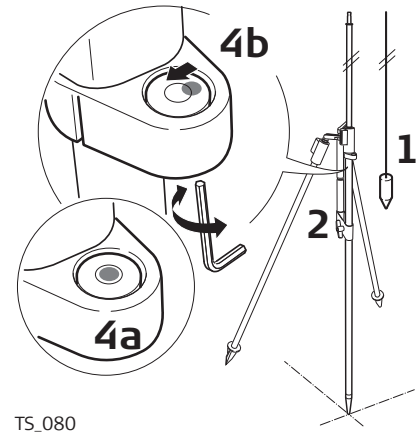

- ☞ After the adjustments, all adjusting screws must have the same tightening tension and no adjusting screw should be loose.

5.6

Inspecting the Laser Plummet of the Instrument



The laser plummet is located in the vertical axis of the instrument. Under normal conditions of use, the laser plummet does not need adjusting. If an adjustment is necessary due to external influences, return the instrument to any Leica Geosystems authorised service workshop.

Inspecting the laser plummet step-by-step

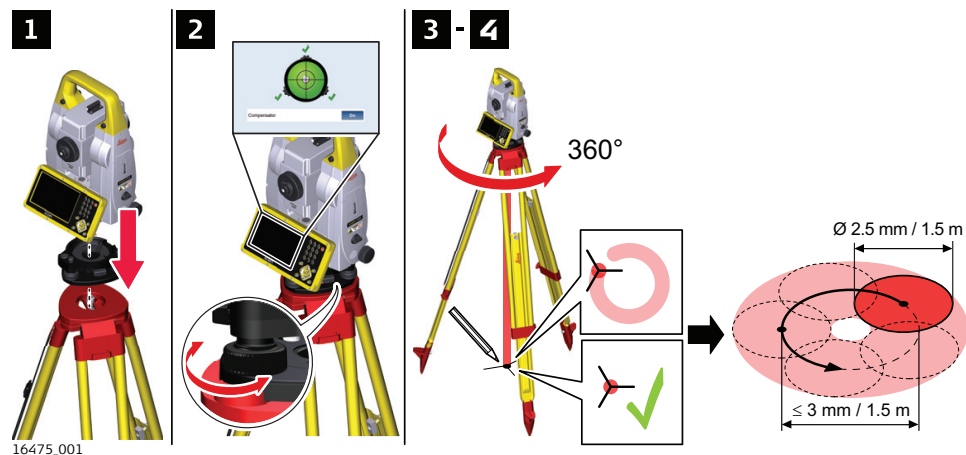

The following table explains the most common settings.

1. Place and secure the instrument into the tribrach and onto a tripod.
2. Turn on the instrument. Using the tribrach footscrews, level the instrument with the electronic level.



Electronic level:

- Select **Devices** from the Home Menu.
- Tap the arrow button to the right of the device name.
- To display the electronic level, tap **Compensator**.

3. The laser plummet is switched on when the Compensator screen is displayed.

☞ Inspection of the laser plummet should be carried out on a bright, smooth and horizontal surface, such as a sheet of paper.

Mark the centre of the red laser dot on the ground.

4. Turn the instrument slowly through 360°, carefully observing the movement of the red laser dot.

☞ The maximum diameter of the circular movement described by the centre of the laser dot should not exceed 3mm at a height of 1.5m.

If the centre of the laser dot describes a perceptible circular movement, or moves more than 3 mm away from the point which was first marked, an adjustment may be required. Inform your nearest Leica Geosystems authorised service centre. Depending on brightness and surface, the diameter of the laser dot can vary. At 1.5 m, it is about 2.5 mm.

5.7

Servicing the Tripod

Servicing the tripod step-by-step

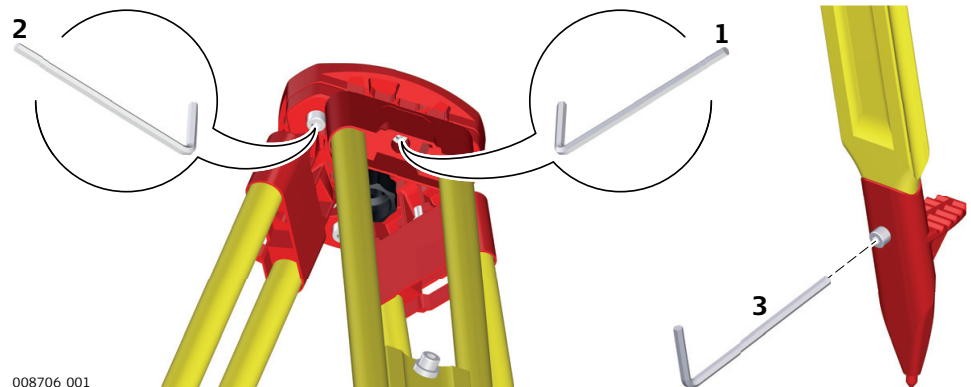

The following table explains the most common settings.

☞ The connections between metal and timber components must always be firm and tight.

1. Tighten the leg cap screws moderately, with the supplied Allen key.
2. Tighten the articulated joints on the tripod head enough to keep the tripod legs open when lifting the tripod off the ground.
3. Tighten the Allen screws of the tripod legs.

6 TPS Specific Functionality within iCON site/ iCON build

6.1 MC Application

Map Screen elements

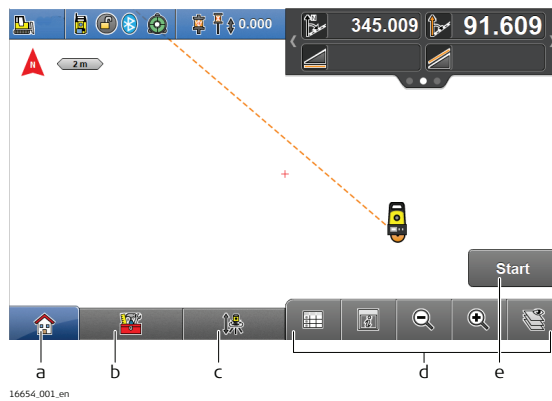

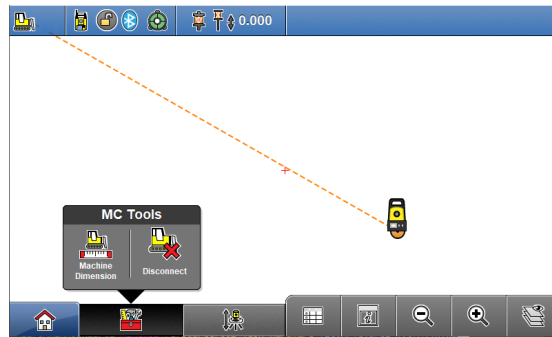

- a Home key
- b Toolbox
- c Setup
- d Map handler
- e Measure bar



Select **MC Tools** from the Map Screen.

MC Tools elements

Element	Description
	Wizard to measure the dimensions of a paving machine.
	To disconnect the TPS from the machine and make the TPS available for other workflows.

6.2 Settings

Communication settings

Select **Com** from the Home Menu.



Set the communication channel. Select between **Cable**, **Int. Bluetooth**, **Bluetooth RAS**, or, when CCD6/ CCD18 is attached, **Bluetooth RAS**.

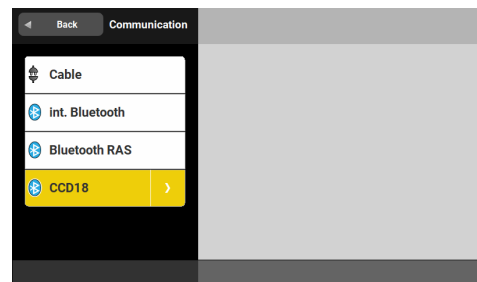

Sensor settings

Select **Sensor** from the Home Menu.



Configure the settings for **Level/Compensator, Sensor Calibration, Atmospheric Corrections** and **Reset Sensor**

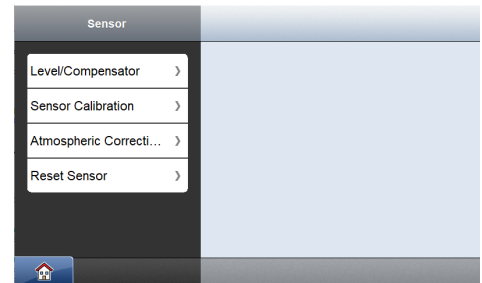

Brightness / Crosshair illumination settings

Select **System** from the Home Menu.



In the **System** screen, select **Brightness**.

- Set the display brightness level to the desired value by pressing the plus/minus button.
- To activate or deactivate the **Keyboard illumination**, tap **On/Off**.
- To activate or deactivate the **Crosshair illumination**, tap **On/Off**.
To change the **Crosshair intensity** press the plus/minus button.
- To set the brightness settings back to default, press the default button. 

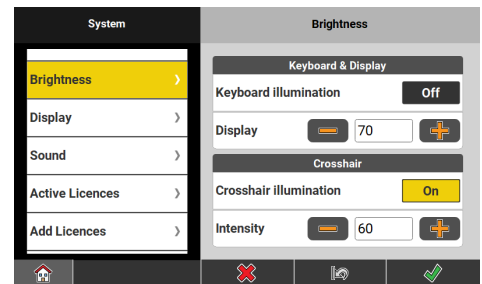

7 Care and Transport

7.1 Transport

Transport in the field	<p>When transporting the equipment in the field, always make sure that you</p> <ul style="list-style-type: none">• either carry the product in its original container,• or carry the tripod with its legs splayed across your shoulder, keeping the attached product upright.
Transport in a road vehicle	<p>Never carry the product loose in a road vehicle, as it can be affected by shock and vibration. Always carry the product in its container and secure it.</p> <p>For products for which no container is available use the original packaging or its equivalent.</p>
Shipping	<p>When transporting the product by rail, air or sea, always use the complete original Leica Geosystems packaging, container and cardboard box, or its equivalent, to protect against shock and vibration.</p>
Shipping, transport of batteries	<p>When transporting or shipping batteries, the person responsible for the product must ensure that the applicable national and international rules and regulations are observed. Before transportation or shipping, contact your local passenger or freight transport company.</p>
Field adjustment	<p>Exposing the product to high mechanical forces, for example through frequent transport or rough handling, or storing the product for a long time may cause deviations and a decrease in the measurement accuracy. Periodically carry out test measurements and perform the field adjustments indicated in the User Manual before using the product.</p>

7.2 Storage

Product	<p>Respect the temperature limits when storing the equipment, particularly in summer if the equipment is inside a vehicle. Refer to 8 Technical Data for information about temperature limits.</p>
Li-Ion batteries	<ul style="list-style-type: none">• Refer to 8 Technical Data for information about storage temperature range• Remove batteries from the product and the charger before storing• After storage recharge batteries before using• Protect batteries from damp and wetness. Wet or damp batteries must be dried before storing or use• A storage temperature range of 0 °C to +30 °C / +32 °F to +86 °F in a dry environment is recommended to minimize self-discharging of the battery• At the recommended storage temperature range, batteries containing a 40% to 50% charge can be stored for up to one year. After this storage period the batteries must be recharged

7.3

Cleaning and Drying

Product and accessories

- Blow dust off lenses and prisms.
 - Never touch the glass with your fingers.
 - Use only a clean, soft, lint-free cloth for cleaning. If necessary, moisten the cloth with water or pure alcohol. Do not use other liquids; these may attack the polymer components.
-

Fogging of prisms

Prisms that are cooler than the ambient temperature tend to fog. It is not enough simply to wipe them. Keep them for some time inside your jacket or in the vehicle to allow them to adjust to the ambient temperature.

Damp products

Dry the product, the transport container, the foam inserts and the accessories at a temperature not greater than 40°C /104°F and clean them. Remove the battery cover and dry the battery compartment. Do not repack until everything is completely dry. Always close the transport container when using in the field.

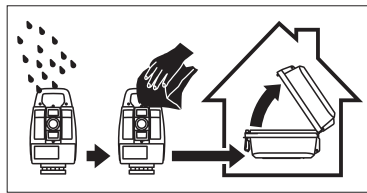

Cables and plugs

Keep plugs clean and dry. Blow away any dirt lodged in the plugs of the connecting cables.

7.4

Maintenance



An inspection of the motorisation in motorised instruments must be done in a Leica Geosystems authorised service centre. Leica Geosystems recommends an inspection of the product every 12 months.

For instruments which are in intensive or permanent use, for example tunneling or monitoring, the recommended inspection cycle may be reduced.

8 Technical Data

8.1 Angle Measurement

Accuracy	Available angular accuracies	Standard deviation Hz, V ISO 17123-3	Display resolution		
	["]	[mgon]	["]	[°]	[mgon]
	1	0.3	1	0.0001	0.1
	2	0.6	1	0.0001	0.1
	5	1.5	1	0.0001	0.1

Characteristics Absolute, continuous, diametric.

8.2 Distance Measurement with Reflectors

Range	Reflector	Range A		Range B		Range C	
		[m]	[ft]	[m]	[ft]	[m]	[ft]
	Standard prism (GPR1)	1800	6000	3000	10000	3500	12000
	Three standard prisms (GPR1)	2300	7500	4500	14700	5400	17700
	360° prism (GRZ4, GRZ122)	800	2600	1500	5000	2000	7000
	360° mini prism (GRZ101)	450	1500	800	2600	1000	3300
	Mini prism (GMP101)	800	2600	1200	4000	2000	7000
	Reflector tape GZM31 60 mm × 60 mm	150	500	250	800	250	800
	Machine Automation power prism (MPR122)	800	2600	1500	5000	2000	7000
	Shortest measuring distance:		1.5 m				

Atmospheric conditions

Range	Description
A	Strong haze, visibility 5 km; or strong sunlight, severe heat shimmer
B	Light haze, visibility about 20 km; or moderate sunlight, slight heat shimmer
C	Overcast, no haze, visibility about 40 km; no heat shimmer



Measurements can be made to reflector tapes over the entire range without external ancillary optics.

Accuracy

Accuracy refers to measurements to standard prisms.

Distance measuring mode	Standard deviation ISO 17123-4, standard prism	Standard deviation ISO 17123-4, tape	Measurement time, typical [s]
Single Auto	1 mm + 1.5 ppm	3 mm + 2 ppm	2.4
Continuous with lock	3 mm + 1.5 ppm	3 mm + 2 ppm	< 0.15

Beam interruptions, severe heat shimmer and moving objects within the beam path can result in deviations of the specified accuracy.

The display resolution is 0.1 mm.

Characteristics

Type	Description
Principle	Phase measurement
Type	Coaxial, visible red laser
Carrier wave	658 nm
Measuring system	System Analyzer Basis 100–150 MHz

8.3

Distance Measurement without Reflectors

Range

R1000

Kodak Gray Card	Range D		Range E		Range F	
	[m]	[ft]	[m]	[ft]	[m]	[ft]
White side, 90% reflective	800	2630	1000	3280	> 1000	> 3280
Grey side, 18% reflective	400	1320	500	1640	> 500	> 1640

Range of measurement:

1.5–1200 m



R30 is able to achieve a range of 30 m/100 ft under all atmospheric conditions.

Display unambiguous:

up to 1200 m

Atmospheric conditions

Range	Description
D	Object in strong sunlight, severe heat shimmer
E	Object in shade, or overcast
F	Underground, night and twilight

Accuracy

Standard measuring [m]	Standard deviation [mm] ISO 17123-4	Measure time, typical [s]	Measure time, maximum [s]
0–500	2 + 2 ppm	3–6	12

Standard measuring [m]	Standard deviation [mm] ISO 17123-4	Measure time, typical [s]	Measure time, maximum [s]
> 500	4 + 2 ppm	3–6	12

Object in shade, sky overcast. Beam interruptions, severe heat shimmer and moving objects within the beam path can result in deviations of the specified accuracy.

The display resolution is 0.1 mm.

Characteristics

Type	Description
Type	Coaxial, visible red laser
Carrier wave	658 nm
Measuring system	System Analyzer Basis 100–150 MHz

Laser dot size

Distance [m]	Laser dot size, approximately [mm]
at 30	7 × 10
at 50	8 × 20
at 100	16 × 25

8.4

Automatic Target Aiming (ATRplus)

Range of target aiming/ target locking

Reflector	Range (Target Aiming)		Range (Target Locking)	
	[m]	[ft]	[m]	[ft]
Standard prism (GPR1)	1500	6000	1000	3300
360° prism GRZ4, GRZ122)	1000	3250	1000	3300
360° mini prism (GRZ101)	450	1500	250	830
Mini prism (GMP101)	900	2880	600	2000
Reflector tape 60 mm × 60 mm	55	190	not qualified	
Machine Automation power prism (MPR122)	750	2500	650	2200

 The maximum range depends on the atmospheric condition. Rain, strong sunlight or severe heat shimmer can decrease the maximum range.

Shortest measuring distance: 360° prism (target aiming): 1.5 m

Shortest measuring distance: 360° prism (target locking): 5 m

ATRplus accuracy with the GPR1 prism

Type	Accuracy
ATRplus angle accuracy Hz, V (std. dev. ISO 17123-3)	1" (0.3 mgon)

Maximum prism speed

	Direction of prism movement	
	Tangential	Radial
Prism Lock only	14 m/s at 20 m	25 m/s
Prism Lock with Measure Mode Continuous with lock	6 m/s at 20 m	6 m/s

 A tangential movement means the prism is passing by the instrument at the specified distance.
A radial movement means the prism is moving away from or towards the instrument in the line of sight direction.

Searching

Type	Value
Typical search time in field of view	1.5 s
Field of view	1°25'/1.55 gon
Definable search windows	Yes

Characteristics

Type	Description
Principle	Digital image processing
Type	Infrared laser

8.5**PowerSearch****Range**

Reflector	Range	
	[m]	[ft]
Standard prism (GPR1)	300	1000
360° prism (GRZ4, GRZ122)	300*	1000*
360° mini prism (GRZ101)	Not recommended	
Mini prism (GMP101)	100	330

Measurements at the vertical limits of the fan or under unfavourable atmospheric conditions may reduce the maximum range. (*optimally aligned to the instrument)

Shortest measuring distance: 1.5 m

Searching

Type	Value
Typical search time	5 s
Default search area	Hz: 400 gon, V: 40 gon

Type	Value
Definable search windows	Yes

Characteristics

Type	Description
Principle	Digital signal processing
Type	Infrared laser

8.6

LOC8 Theft Deterrence and Location Device (optional)

Internal battery

Battery	Capacity
Li-Ion	800 mAh Recharged by the total station battery when instrument is switched on Up to 5 days Depending on mode of operation and cellular network conditions

Tracking period

Update rate up to 1 minute

Interfaces

Wi-Fi: 802.11 b/g/n

Environmental specifications

Temperature

Operating temperature [°C]	Storage temperature [°C]
-20 to +60	-20 to +60

8.7

General Technical Data of the Product

System accuracy

Several factors can influence the accuracy of the system for determining the location of a prism:

- Internal ATRplus accuracy
- Angular accuracy of the instrument
- Type and centring accuracy of the prism
- Selected EDM measuring program
- External measuring conditions

Therefore, the overall pointing accuracy of the determined point location can be lower than the given angular accuracy and the ATRplus accuracy.

The following paragraphs provide a short overview of these influencing factors and their possible intensities.

Angular accuracy

The accuracy of angular measurements depends on the instrument type. The angular accuracy for total stations is typically in the range from 0.5" to 5". The resulting error depends on the measurement distance.

The table shows possible deviations for typical angular accuracies. 1" and 3" are examples.

Angular accuracy	Possible deviation* at 100 m distance
1"	~0.5 mm
3"	~1.5 mm

* Orthogonal to the line of sight.

 Refer to the data sheet of the respective instrument model for information about the angular accuracy.

EDM accuracy

The distance measurement accuracy consists of two parts: a fixed value and a distance-dependent value (ppm-value).

Example: "Single measurements: 1 mm + 1.5 ppm"

The EDM accuracies for prism and reflectorless measurements can differ. Additionally, the accuracies can differ depending on the used technologies.

 Refer to the appropriate data sheet for information about the EDM accuracy.

ATRplus accuracy

Automatic target aiming accuracies, like those of the ATRplus, are in general the same as the stated angular accuracy. Therefore these accuracies are also distance-dependent parameters.

External impacts, like heat shimmer, rain (prism surface covered by rain drops), fog, dust, strong background lights, dirty targets, alignment of the targets etc. can have a significant influence on the automated target. In addition, the selected EDM mode affects the ATRplus performance. Under good environmental conditions and with a clean, properly aligned target the accuracy of the automated target aiming is equivalent to the manual target aiming (presumed valid calibration values).

Type and centring accuracy of the prism

The prism centring accuracy depends mainly on the used prism type, for example:

Prism type	Centring accuracy
Leica GPR1	Circular prism 1.0 mm
Leica GPH1P	Precision circular prism 0.3 mm
Leica GRZ122	360° prism 2.0 mm
Leica GRZ4	360° prism 5.0 mm

 Refer to the white paper "Leica Surveying Reflectors" for information about the different centring accuracies.

More influencing factors

When determining absolute coordinates, the following parameters can also affect the resulting accuracy:

- Environmental conditions: temperature, air pressure and humidity
- Typical instrument errors, such as horizontal collimation error or index error.
- Proper functioning of laser plummet or optical plummet
- Correct horizontal levelling
- Setup of the target
- Quality of extra equipment, such as tribrach or tripod.

Telescope

Type	Value
Magnification	30 ×
Free Objective aperture	40 mm
Focusing	1.7 m/5.6 ft to infinity
Field of view	1°30'/1.66 gon 2.7 m at 100 m

Compensator

Angular accuracy instrument ["]	Setting accuracy		Setting range	
	["]	[mgon]	[']	[gon]
1	0.5	0.2	4	0.07
2	0.5	0.2	4	0.07
5	1.5	0.5	4	0.07

Level

Type	Value
Circular level sensitivity	6'/2 mm
Electronic level resolution	2"
Compensation	Centralised quadruple axis compensation

Control unit

Type	Description
Display	WVGA (800 × 480 pixels), colour, graphics capable LCD, illumination, touch screen
Keyboard	22 keys Illumination
Angle display	360 ⁰⁰⁰ , 360° decimal, 400 gon, H:V, V:H, V%
Distance display	m, ft int, ft us, ft int inch, ft us inch
Position	In both faces, face two is optional
Touch screen	Screen protection foil on glass

Instrument ports

Name	Description
Cable	<ul style="list-style-type: none"> • 5 pin LEMO-0 for power, communication, data transfer. • This port is located at the base of the instrument.

Name	Description
CommunicationHandle	<ul style="list-style-type: none"> Hotshoe connection for Communication-Handle. This port is located on top of Communication side cover.
Bluetooth	<ul style="list-style-type: none"> Bluetooth module for communication. This port is housed within Communication side cover.
USB host port	<ul style="list-style-type: none"> USB memory stick port for data transfer.
USB device port	<ul style="list-style-type: none"> Cable connections from USB devices for communication and data transfer.
WLAN	<ul style="list-style-type: none"> WLAN module for communication. This port is housed within the Communication side cover.

Pin assignments of the 5 pin LEMO-0 port

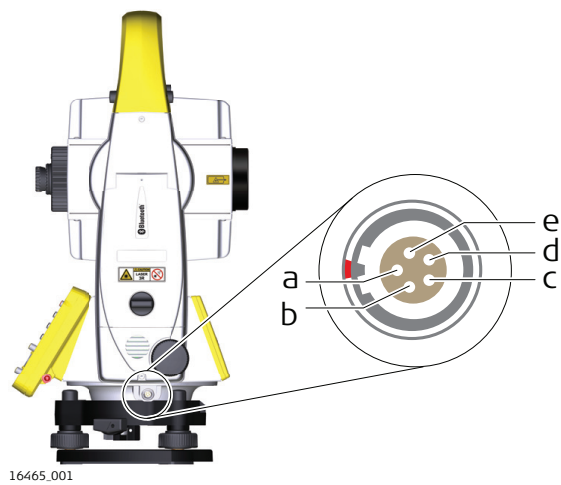

- a Pin 1: Power input
- b Pin 2: Not used
- c Pin 3: Single ground
- d Pin 4: RxD (RS232, receive data, In)
- e Pin 5: TxD (RS232, transmit data, Out)

Instrument dimensions

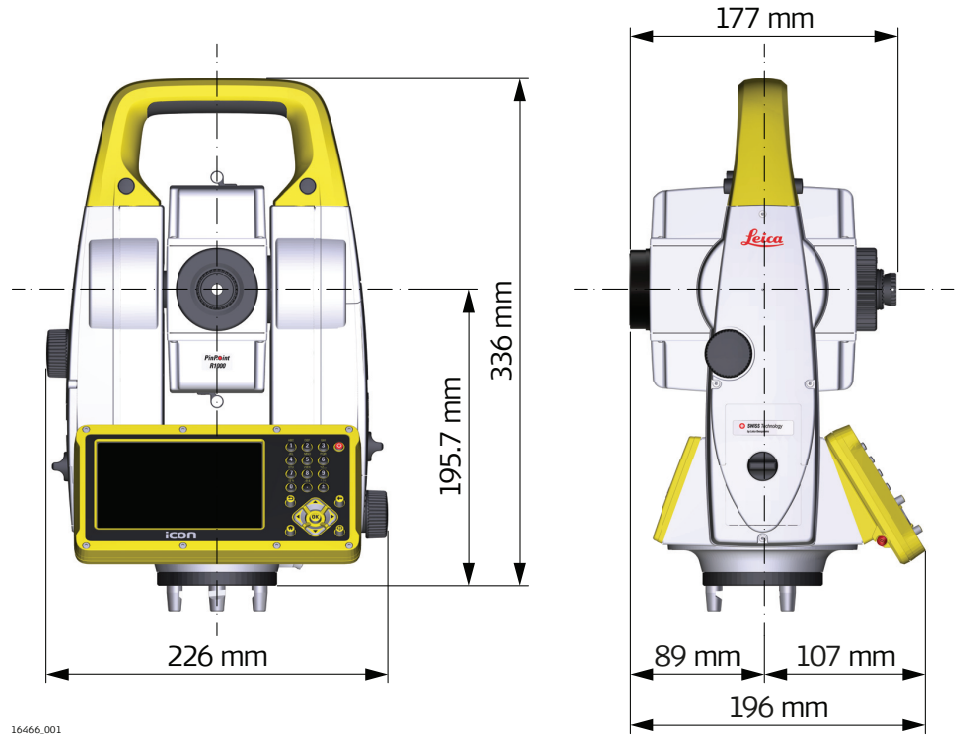

16466_001

With CCD18

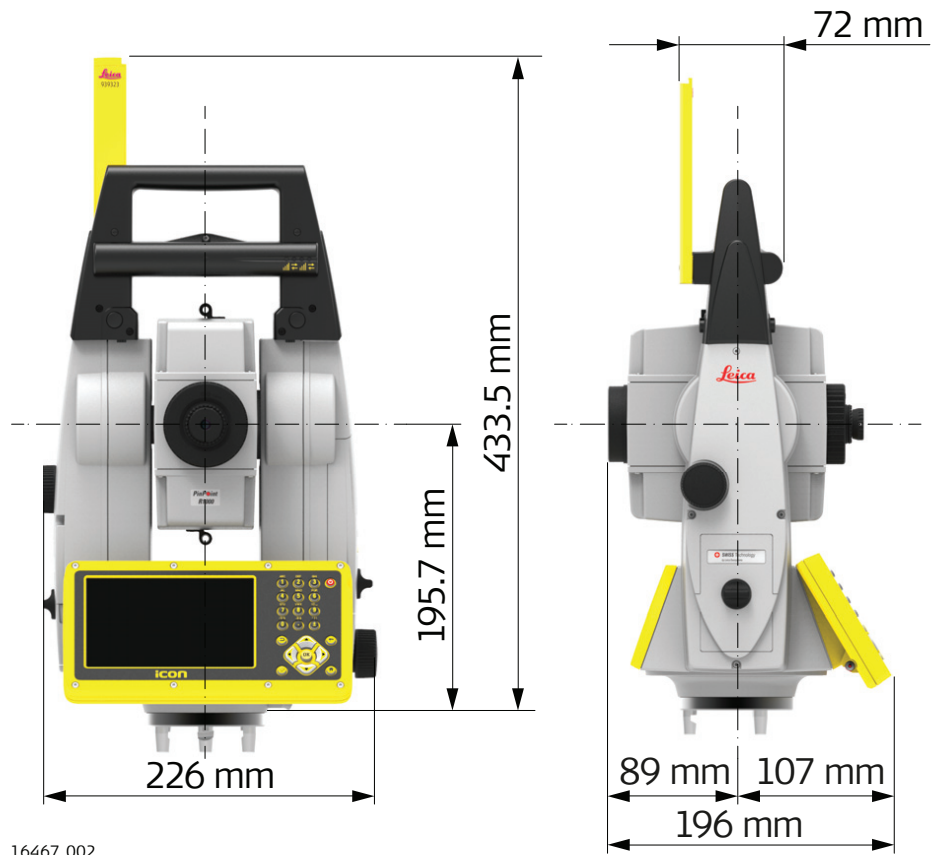

16467_002

Weight

Instrument (including battery): 5.3 kg

Tribrach:

0.8 kg

Recording

Data can be recorded in the internal memory. Recorded data can be exported to an SD card or USB Stick.

Type	Capacity [MB]	Number of measurements per MB
Internal memory	2048	1750
SD card	<ul style="list-style-type: none"> • 1024 • 8192 	1750
USB stick	1024	1750

Laser plummet

Type	Value
Type	Visible red laser class 2
Location	In standing axis of instrument
Accuracy	Deviation from plumb line: 1.5 mm (2 sigma) at 1.5 m instrument height
Diameter of laser point	2.5 mm at 1.5 m instrument height

Drives

Description
Endless horizontal and vertical drives

Motorisation

Type	Description
Maximum rotating speed	50 gon/s

Power

Type	Description
External supply voltage	Nominal voltage 12.8 V DC, Range 11.5 V-13.5 V

Internal battery

Type	Battery	Nominal Voltage	Capacity
GEB222	Li-Ion	7.4 V \approx	6.0 Ah

External battery

Type	Battery	Voltage	Capacity
GEB373	Li-Ion	14.4V \approx	20.1 Ah

Environmental specifications

Temperature

Type	Operating temperature [°C]	Storage temperature [°C]
All instruments	-20 to +50	-40 to +70
Leica SD cards	-40 to +80	-40 to +80
Battery internal	-20 to +55	-40 to +70

Protection against water, dust and sand

Type	Protection
All instruments	IP55 (IEC 60529)

Humidity

Type	Protection
All instruments	Max 95% non condensing The effects of condensation are to be effectively counteracted by periodically drying out the instrument.

Reflectors

Type	Additive Constant [mm]	ATRplus	PS
Standard prism, GPR1	0.0	yes	yes
Mini prism, GMP101	+17.5	yes	yes
360° prism, GRZ4 / GRZ122	+23.1	yes	yes
360° mini prism, GRZ101	+30.0	yes	not recommended
Reflector tape S, M, L	+34.4	yes	no
Reflectorless	+34.4	no	no
Machine Automation power prism, MPR122	+28.1	yes	yes

There are no special prisms required for ATRplus or for PS.

Electronic Guide Light (EGL)

Working range: 5 m to 150 m (15 ft to 500 ft)
Position accuracy: 5 cm at 100 m (1.97" at 330 ft)

Automatic corrections

The following automatic corrections are made:

- Line of sight error
- Tilting axis error
- Earth curvature
- Circle eccentricity
- Compensator index error
- Vertical index error
- Standing axis tilt
- Refraction
- ATRplus zero point error

8.8

Scale Correction

Use of scale correction

By entering a scale correction, reductions proportional to distance can be taken into account.

- Atmospheric correction.
- Reduction to mean sea level.
- Projection distortion.

Atmospheric correction $\Delta D1$

The slope distance displayed is correct if the scale correction in ppm, mm/km, which has been entered corresponds to the atmospheric conditions prevailing at the time of the measurement.

The atmospheric correction includes:

- Adjustments for air pressure
- Air temperature
- Relative humidity

For highest precision distance measurements, the atmospheric correction should be determined with an accuracy of 1 ppm. The following parameters must be redetermined:

- Air temperature to 1 °C
- Air pressure to 3 mbar
- Relative humidity to 20%

Air humidity

The air humidity influences the distance measurement if the climate is extremely hot and damp.

For high precision measurements, the relative humidity must be measured and entered along with the air pressure and the temperature.

Air humidity correction

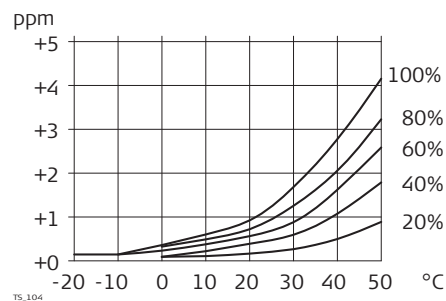

ppm Air humidity correction [mm/km]
% Relative humidity [%]
°C Air temperature [°C]

Index n

Type	Index n	Carrier wave [nm]
Combined EDM	1.0002863	658

The index n is calculated from the formula of the IAG Resolutions (1999), and is valid for:

Air pressure p:	1013.25 mbar
Air temperature t:	12 °C
Relative air humidity h:	60%

Formulas

Formula for visible red laser

$$\Delta D_1 = 286.338 - \left[\frac{0.29535 \cdot p}{(1 + \alpha \cdot t)} - \frac{4.126 \cdot 10^{-4} \cdot h}{(1 + \alpha \cdot t)} \right] \cdot 10^x$$

002419.002

ΔD_1 Atmospheric correction [ppm]

p Air pressure [mbar]

t Air temperature [°C]

h Relative humidity [%]

$\alpha = \frac{1}{273.15}$

$x = (7.5 \cdot t / (237.3 + t)) + 0.7857$

If the basic value of 60 % relative humidity as used by the EDM is retained, the maximum possible error in the calculated atmospheric correction is 2 ppm, 2 mm/km.

Reduction to mean sea level ΔD_2

The values for ΔD_2 are always negative and are derived from the following formula:

$$\Delta D_2 = - \frac{H}{R} \cdot 10^6$$

TS_106

ΔD_2 Reduction to mean sea level [ppm]

H Height of EDM above sea level [m]

$R = 6.378 \cdot 10^6$ m

Projection distortion ΔD_3

The magnitude of the projection distortion is in accordance with the projection system used in a particular country, for which official tables are generally available. The following formula is valid for cylindrical projections such as that of Gauss-Krüger:

$$\Delta D_3 = \frac{X^2}{2R^2} \cdot 10^6$$

TS_107

ΔD_3 Projection distortion [ppm]

X Easting, distance from projection zero line with the scale factor 1 [km]

$R = 6.378 \cdot 10^6$ m

In countries where the scale factor is not unity, this formula cannot be directly applied.

Atmospheric corrections °C

Atmospheric corrections in ppm with temperature [°C], air pressure [mb] and height [m] at 60% relative humidity.

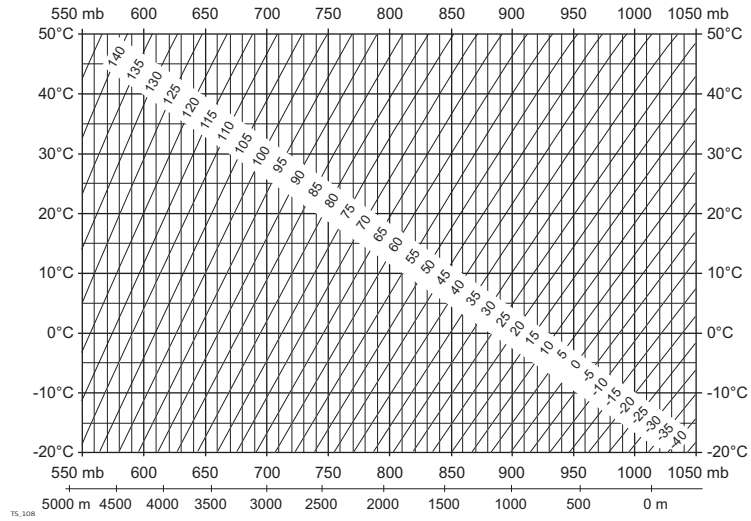

Atmospheric corrections °F

Atmospheric corrections in ppm with temperature [°F], air pressure [inch Hg] and height [ft] at 60% relative humidity.

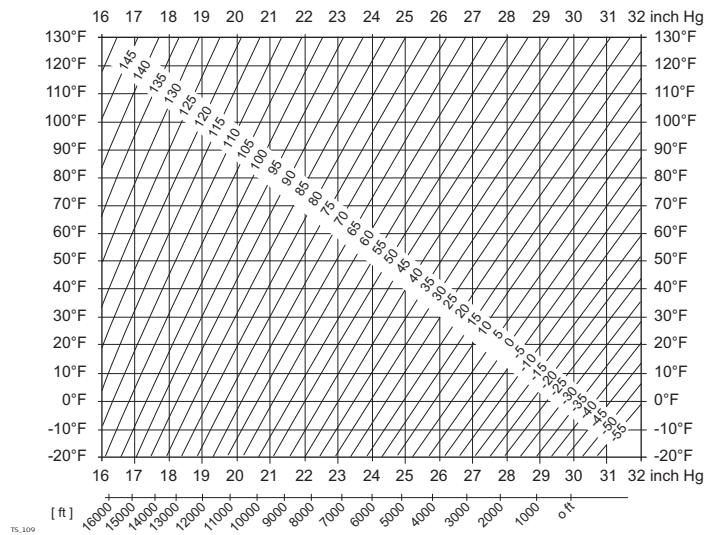

Formulas

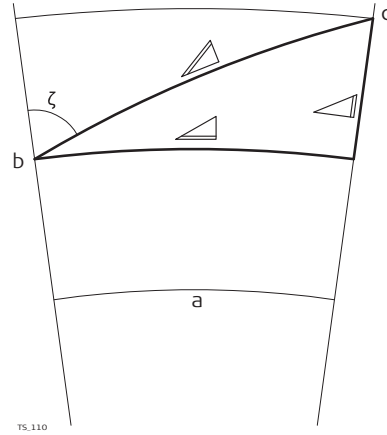

- a Mean Sea Level
- b Instrument
- c Reflector
- \sphericalangle Slope distance
- \sphericalangle Horizontal distance
- \sphericalangle Height difference

The instrument calculates the slope distance, horizontal distance, height difference in accordance with the following formulas:

$$\sphericalangle = D_0 \cdot (1 + \text{ppm} \cdot 10^{-6}) + AC$$

002425.002

- \sphericalangle Displayed slope distance [m]
- D_0 Uncorrected distance [m]
- ppm Atmospheric scale correction [mm/km]
- AC Additive constant of the reflector [m]

$$\sphericalangle = Y - A \cdot X \cdot Y$$

TS.112

$$\sphericalangle = X + B \cdot Y^2$$

TS.113

- \sphericalangle Horizontal distance [m]
- \sphericalangle Height difference [m]
- Y $\sphericalangle \cdot |\sin \zeta|$
- X $\sphericalangle \cdot \cos \zeta$
- ζ Vertical circle reading
- A $(1 - k / 2) / R = 1.47 \cdot 10^{-7} \text{ [m}^{-1}\text{]}$
- B $(1 - k) / (2 \cdot R) = 6.83 \cdot 10^{-8} \text{ [m}^{-1}\text{]}$
- k 0.13 (mean refraction coefficient)
- R $6.378 \cdot 10^6 \text{ m}$ (radius of the earth)

Earth curvature (1/R) and mean refraction coefficient (k) are automatically taken into account when calculating the horizontal distance and height difference. The calculated horizontal distance relates to the station height and not to the reflector height.

Reflector types

The reduction formulas are valid for measurements to all reflector types:

- To prisms
- To reflector tape
- Reflectorless measurements

Formulas

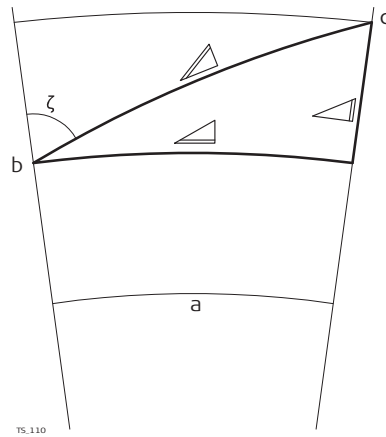

- a Mean Sea Level
- b Instrument
- c Reflector
- ▴ Slope distance
- ▴ Horizontal distance
- ▴ Height difference

The instrument calculates the slope distance, horizontal distance, height difference in accordance with the following formulas:

$$\triangle = D_0 \cdot (1 + \text{ppm} \cdot 10^{-6}) + AC$$

002425_002

- ▴ Displayed slope distance [m]
- D_0 Uncorrected distance [m]
- ppm Atmospheric scale correction [mm/km]
- AC Additive constant of the reflector [m]

$$\triangle = Y - A \cdot X \cdot Y$$

TS.112

$$\triangle = X + B \cdot Y^2$$

TS.113

- ▴ Horizontal distance [m]
- ▴ Height difference [m]
- Y ▴ * |sinζ|
- X ▴ * cosζ
- ζ Vertical circle reading
- A $(1 - k / 2) / R = 1.47 * 10^{-7} \text{ [m}^{-1}\text{]}$
- B $(1 - k) / (2 * R) = 6.83 * 10^{-8} \text{ [m}^{-1}\text{]}$
- k 0.13 (mean refraction coefficient)
- R $6.378 * 10^6 \text{ m}$ (radius of the earth)

Earth curvature (1/R) and mean refraction coefficient (k) are automatically taken into account when calculating the horizontal distance and height difference. The calculated horizontal distance relates to the station height and not to the reflector height.

8.10

Conformity to National Regulations

8.10.1

iCR80

Labelling iCR80

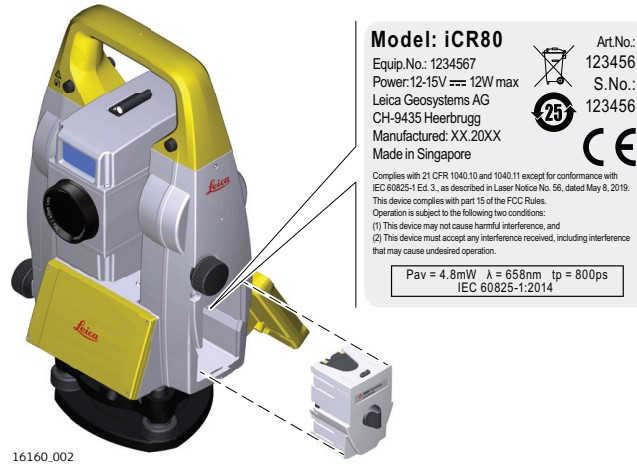

Labelling internal battery GEB222

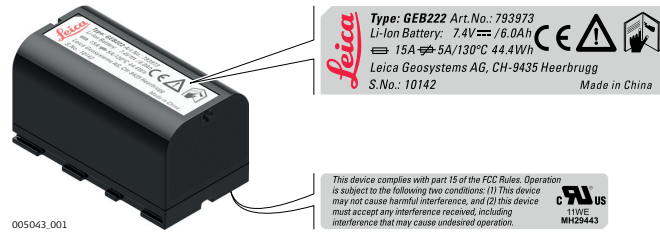

Frequency band

Type	Frequency Band [MHz]
Bluetooth	2402–2480
WLAN	2400–2473, channel 1–11

Output power

Type	Output Power [mW]
Bluetooth	<10
WLAN (802.11b)	50
WLAN (802.11g)	32

Antenna

Type	Bluetooth	WLAN
Antenna	Integrated antenna	Integrated antenna
Gain [dBi]	0	0
Connector	–	–
Frequency band [MHz]	2400–2500	2400–2500

EU



Hereby, Leica Geosystems AG declares that the radio equipment type iCR80 is in compliance with Directive 2014/53/EU and other applicable European Directives.
The full text of the EU declaration of conformity is available at the following Internet address: <http://www.leica-geosystems.com/ce>.

This equipment has been tested and found to comply with the limits for a Class B digital device, pursuant to part 15 of the FCC Rules.

These limits are designed to provide reasonable protection against harmful interference in a residential installation.

This equipment generates, uses, and can radiate radio frequency energy and, if not installed and used in accordance with the instructions, it may cause harmful interference to radio communications.

However, there is no guarantee that interference does not occur in a particular installation.

If this equipment does cause harmful interference to radio or television reception, which can be determined by turning the equipment off and on, the user is encouraged to try to correct the interference by one or more of the following measures:

- Reorient or relocate the receiving antenna.
- Increase the separation between the equipment and the receiver.
- Connect the equipment into an outlet on a circuit different from that to which the receiver is connected.
- Consult the dealer or an experienced radio/TV technician for help.

Changes or modifications not expressly approved by Leica Geosystems for compliance could void the user's authority to operate the equipment.

Canada

CAN ICES-003 B/NMB-003 B

Japan

- This device is granted pursuant to the Japanese Radio Law (電波法).
- This device should not be modified (otherwise the granted designation number will become invalid).

Others

The conformity for countries with other national regulations has to be approved prior to use and operation.

8.10.2

CommunicationHandle

Labelling Communication- Handle

CCD6



16501_002

Type: CCD6 Art.No.: 823111 Power: 5.0-17.5V=/ 0.2A max. Leica Geosystems AG CH-9435 Heerbrugg Manufactured: 20xx Made in Austria Contains transmitter module. FCC ID: PjH0946 IC: 5325A-0946		This device complies with part 15 of the FCC Rules. Operation is subject to the following two conditions: (1) This device may not cause harmful interference, and (2) this device must accept any interference received, including interference that may cause undesired operation.
	S.No.: 1234567	

Labelling Communication- Handle

CCD18



24853_001

Model: CCD18 Art. No.: 922941 Serial No.: 123456 Power: 5.0V - 17.5VDC=3W max. Leica Geosystems AG CH-9435 Heerbrugg Made in Austria Manufactured: MM.YYYY		This device complies with part 15 of the FCC Rules. Operation is subject to the following two conditions: (1) This device may not cause harmful interference, and (2) this device must accept any interference received, including interference that may cause undesired operation.
	YU10456-16004 AIS-82 31 620 6252 FCC ID: X000XXXX IC: X000XXXX QRRT ID: X0000Z0000	

Frequency band

Type	Frequency Band [MHz]
CCD6	Limited to 2402–2480
CCD18	Limited to 2402–2480
RH17	Limited to 2402–2480
RH18	Limited to 2402–2480

Output power

Value
< 100 mW (e. i. r. p.)

Antenna

Type	$\lambda/2$ dipole antenna
Gain [dBi]	2
Connector	Special customized SMB

EU



Hereby, Leica Geosystems AG declares that the radio equipment type CommunicationHandle is in compliance with Directive 2014/53/EU and other applicable European Directives. The full text of the EU declaration of conformity is available at the following Internet address: <http://www.leica-geosystems.com/ce>.

USA

FCC ID: PVH0946, RFD-RH18
Part 15

This equipment has been tested and found to comply with the limits for a Class B digital device, pursuant to part 15 of the FCC Rules.

These limits are designed to provide reasonable protection against harmful interference in a residential installation.

This equipment generates, uses, and can radiate radio frequency energy and, if not installed and used in accordance with the instructions, it may cause harmful interference to radio communications.

However, there is no guarantee that interference does not occur in a particular installation.

If this equipment does cause harmful interference to radio or television reception, which can be determined by turning the equipment off and on, the user is encouraged to try to correct the interference by one or more of the following measures:

- Reorient or relocate the receiving antenna.
- Increase the separation between the equipment and the receiver.
- Connect the equipment into an outlet on a circuit different from that to which the receiver is connected.
- Consult the dealer or an experienced radio/TV technician for help.

Changes or modifications not expressly approved by Leica Geosystems for compliance could void the user's authority to operate the equipment.

Canada

CAN ICES-003 B/NMB-003 B
IC: 5325A-0946, 3177A-RH18

Others

The conformity for countries with other national regulations has to be approved prior to use and operation.

8.10.3

LOC8 Theft Deterrence and Location Device (optional)

Specific Absorption Rate (SAR)

The product meets the limits for the maximum permissible exposure of the guide-lines and standards which are force in this respect. The product must be used with the recommended antenna. A separation distance of at least 20 centimetres should be kept between the antenna and the body of the user or nearby person within the intended application.

Frequency band

Type	Value
GSM	GSM 900: 880 - 960 MHz GSM 1800: 1710 - 1880 MHz

Type	Value
WCDMA	WCDMA 900: 880 - 960 MHz WCDMA 2100: 1920 - 2170 MHz
WLAN	2.4G Wi-Fi 802.11 b/g/n (20 MHz): 2412 - 2472 MHz 802.11 n (40 MHz): 2422 ~ 2462 MHz
GPS	1.57542 GHz

Output power

Type	Value
GSM	GPRS: Maximal power: 29,13 dBm
WCDMA	Maximal power: 23,58 dBm
GPS	Receive only
WLAN	Receive only

Antenna

Type	Antenna	Gain
GSM	Internal PIFA antenna	GSM 900: 0.23 dBi GSM 1800: 0.23 dBi
WCDMA	Internal antenna	WCDMA 900: 1.34 dB WCDMA 1200: 1.34 dBi
GPS	Internal antenna	0 dBi
WLAN	Internal PIFA antenna	-0.66 dBi

EU



Hereby, Leica Geosystems AG declares that the radio equipment type LOC8 is in compliance with Directive 2014/53/EU and other applicable European Directives.

The full text of the EU declaration of conformity is available at the following Internet address: <http://www.leica-geosystems.com/ce>.

USA

FCC ID: 2AAI6-TRKM015-LC
Part 15, 22 and 24

Changes or modifications not expressly approved by Leica Geosystems for compliance could void the user's authority to operate the equipment.

Others

The conformity for countries with other national regulations has to be approved prior to use and operation.

8.10.4

Dangerous Goods Regulations

Dangerous Goods Regulations

Many products of Leica Geosystems are powered by Lithium batteries. Lithium batteries can be dangerous under certain conditions and can pose a safety hazard. In certain conditions, Lithium batteries can overheat and ignite.



When carrying or shipping your Leica product with Lithium batteries onboard a commercial aircraft, you must do so in accordance with the **IATA Dangerous Goods Regulations**.

- ☞ Leica Geosystems has developed **Guidelines** on “How to carry Leica products” and “How to ship Leica products” with Lithium batteries. Before any transportation of a Leica product, we ask you to consult these guidelines on our web page ([IATA Lithium Batteries](#)) to ensure that you are in accordance with the IATA Dangerous Goods Regulations and that the Leica products can be transported correctly.
 - ☞ Damaged or defective batteries are prohibited from being carried or transported onboard any aircraft. Therefore, ensure that the condition of any battery is safe for transportation.
-

Software Licence Agreement

This product contains software that is preinstalled on the product, or that is supplied to you on a data carrier medium, or that can be downloaded by you online according to prior authorisation from Leica Geosystems. Such software is protected by copyright and other laws and its use is defined and regulated by the Leica Geosystems Software Licence Agreement, which covers aspects such as, but not limited to, Scope of the Licence, Warranty, Intellectual Property Rights, Limitation of Liability, Exclusion of other Assurances, Governing Law and Place of Jurisdiction. Please make sure, that at any time you fully comply with the terms and conditions of the Leica Geosystems Software Licence Agreement.

Such agreement is provided together with all products and can also be referred to and downloaded at the Leica Geosystems home page at [Hexagon – Legal Documents](#) or collected from your Leica Geosystems distributor.

You must not install or use the software unless you have read and accepted the terms and conditions of the Leica Geosystems Software Licence Agreement. Installation or use of the software or any part thereof, is deemed to be an acceptance of all the terms and conditions of such Licence Agreement. If you do not agree to all or some of the terms of such Licence Agreement, you must not download, install or use the software and you must return the unused software together with its accompanying documentation and the purchase receipt to the distributor from whom you purchased the product within ten (10) days of purchase to obtain a full refund of the purchase price.

Open Source information

The software on the product may contain copyright-protected software that is licenced under various open source licences.

Copies of the corresponding licences

- are provided together with the product (for example in the About panel of the software)
- can be downloaded on <http://opensource.leica-geosystems.com>

If foreseen in the corresponding open source licence, you may obtain the corresponding source code and other related data on <http://opensource.leica-geosystems.com>.

Contact

opensource@leica-geosystems.com in case you need additional information.

PART 2

AutoPole

10

Safety Directions

10.1

General Introduction

Description

The following directions enable the person responsible for the product, and the person who actually uses the equipment, to anticipate and avoid operational hazards.

The person responsible for the product must ensure that all users understand these directions and adhere to them.

About warning messages





Warning messages are an essential part of the safety concept of the instrument. They appear wherever hazards or hazardous situations can occur.

Warning messages...

- make the user alert about direct and indirect hazards concerning the use of the product.
- contain general rules of behaviour.

For the users' safety, all safety instructions and safety messages shall be strictly observed and followed! Therefore, the manual must always be available to all persons performing any tasks described here.

DANGER, WARNING, CAUTION and **NOTICE** are standardised signal words for identifying levels of hazards and risks related to personal injury and property damage. For your safety, it is important to read and fully understand the following table with the different signal words and their definitions! Supplementary safety information symbols may be placed within a warning message as well as supplementary text.

Type	Description
 DANGER	Indicates an imminently hazardous situation which, if not avoided, will result in death or serious injury.
 WARNING	Indicates a potentially hazardous situation or an unintended use which, if not avoided, could result in death or serious injury.
 CAUTION	Indicates a potentially hazardous situation or an unintended use which, if not avoided, may result in minor or moderate injury.
NOTICE	Indicates a potentially hazardous situation or an unintended use which, if not avoided, may result in appreciable material, financial and environmental damage.
	Important paragraphs which must be adhered to in practice as they enable the product to be used in a technically correct and efficient manner.

Additional symbols

	Warning against explosive material.
-------------------------------------------------------------------------------------	-------------------------------------



Warning against flammable substances.



Product must not be opened or modified or tampered with.



Indicates the temperature limits at which the product may be stored, transported or used.

10.2

Definition of Use

Intended use

- Measuring pole length
- Measuring pole tilt and computing coordinates
- Verifying target ID
- Data transfer with Bluetooth®
- Data communication with external appliances
- Remote control of product
- Computing with software
- Laying out points and designs, for example from blueprint
- Automatic target search, recognition and tracking
- Measuring coordinates

Reasonably Foreseeable Misuse

- Use of the product without instruction
- Use outside of the intended use and limits
- Disabling of safety systems
- Removal of hazard notices
- Opening the product using tools, for example a screwdriver, unless this is permitted for certain functions
- Modification or conversion of the product
- Use after misappropriation
- Use of products with recognisable damage or defects
- Use with accessories from other manufacturers without the prior explicit approval of Leica Geosystems
- Deliberate dazzling of third parties
- Inadequate safeguards at the working site

10.3

Limits of Use

Environment

Suitable for use in an atmosphere appropriate for permanent human habitation. Not suitable for use in aggressive or explosive environments.

WARNING

Working in hazardous areas or close to electrical installations or similar situations

Life Risk.

Precautions:

- ▶ Local safety authorities and safety experts must be contacted by the person responsible for the product before working in such conditions.

10.4

Responsibilities

Manufacturer of the product

Leica Geosystems AG, CH-9435 Heerbrugg, hereinafter referred to as Leica Geosystems, is responsible for supplying the product, including the User Manual and original accessories, in a safe condition.

Person responsible for the product

The person responsible for the product has the following duties:

- To understand the safety instructions on the product and the instructions in the User Manual
- To ensure that it is used in accordance with the instructions
- To be familiar with local regulations relating to safety and accident prevention
- To stop operating the system and inform Leica Geosystems immediately if the product and the application become unsafe
- To ensure that the national laws, regulations and conditions for the operation of the products are respected

10.5

Hazards of Use

NOTICE

Dropping, misusing, modifying, storing the product for long periods or transporting the product

Watch out for erroneous measurement results.

Precautions:

- ▶ Periodically carry out test measurements and perform the field adjustments indicated in the User Manual, particularly after the product has been subjected to abnormal use as well as before and after important measurements.

⚠ DANGER

Risk of electrocution

Because of the risk of electrocution, it is dangerous to use poles, levelling staffs and extensions in the vicinity of electrical installations such as power cables or electrical railways.

Precautions:

- ▶ Keep at a safe distance from electrical installations. If it is essential to work in this environment, first contact the safety authorities responsible for the electrical installations and follow their instructions.



⚠ WARNING

Lightning strike

If the product is used with accessories, for example masts, staffs, poles, you may increase the risk of being struck by lightning.

Precautions:

- ▶ Do not use the product in a thunderstorm.

WARNING

Distraction/loss of attention

During dynamic applications, for example stakeout procedures, there is a danger of accidents occurring if the user does not pay attention to the environmental conditions around, for example obstacles, excavations or traffic.

Precautions:

- ▶ The person responsible for the product must make all users fully aware of the existing dangers.

WARNING

Inadequate securing of the working site

This can lead to dangerous situations, for example in traffic, on building sites and at industrial installations.

Precautions:

- ▶ Always ensure that the working site is adequately secured.
- ▶ Adhere to the regulations governing safety, accident prevention and road traffic.

CAUTION

Not properly secured accessories

If the accessories used with the product are not properly secured and the product is subjected to mechanical shock, for example blows or falling, the product may be damaged or people can sustain injury.

Precautions:

- ▶ When setting up the product, make sure that the accessories are correctly adapted, fitted, secured, and locked in position.
- ▶ Avoid subjecting the product to mechanical stress.

For the AC/DC power supply:

WARNING

Electric shock due to use under wet and severe conditions

If unit becomes wet it may cause you to receive an electric shock.

Precautions:

- ▶ If the product becomes humid, it must not be used!
- ▶ Use the product only in dry environments, for example in buildings or vehicles.



- ▶ Protect the product against humidity.

For the AC/DC power supply:

WARNING

Unauthorised opening of the product

Either of the following actions may cause you to receive an electric shock:

- Touching live components
- Using the product after incorrect attempts were made to carry out repairs.

Precautions:

- ▶ Do not open the product!
 - ▶ Only Leica Geosystems authorised service centres are entitled to repair these products.
-

WARNING

Inappropriate mechanical influences to batteries

During the transport, shipping or disposal of batteries it is possible for inappropriate mechanical influences to constitute a fire hazard.

Precautions:

- ▶ Before shipping the product or disposing it, discharge the batteries by the product until they are flat.
 - ▶ When transporting or shipping batteries, the person in charge of the product must ensure that the applicable national and international rules and regulations are observed.
 - ▶ Before transportation or shipping, contact your local passenger or freight transport company.
-

WARNING

Exposure of batteries to high mechanical stress, high ambient temperatures or immersion into fluids

This can cause leakage, fire or explosion of the batteries.

Precautions:

- ▶ Protect the batteries from mechanical influences and high ambient temperatures. Do not drop or immerse batteries into fluids.
-

WARNING

Wet or moisture conditions

The housing around the battery has wiring which may produce a short-circuit.

Precautions:

- ▶ Do not place the battery system in water or expose it to moisture, lubricants, solvents or any other liquid.
-

⚠ WARNING

Improperly battery handling

Risk of fire, explosion or burn.

Precautions:

- ▶ Only replace battery with supported type.
- ▶ Prevent heating the battery above 70 °C.
- ▶ Never throw battery into fire.
- ▶ Do not disassemble, crush, or modify the battery.

⚠ WARNING

Short circuit of battery terminals

If battery terminals are short circuited e.g. by coming in contact with jewellery, keys, metallised paper or other metals, the battery can overheat and cause injury or fire, for example by storing or transporting in pockets.

Precautions:

- ▶ Make sure that the battery terminals do not come into contact with metallic/conductive objects.

⚠ WARNING

Improper disposal

If the product is improperly disposed of, the following can happen:

- If polymer parts are burnt, poisonous gases are produced which may impair health.
- If batteries are damaged or are heated strongly, they can explode and cause poisoning, burning, corrosion or environmental contamination.
- By disposing of the product irresponsibly you may enable unauthorised persons to use it in contravention of the regulations, exposing themselves and third parties to the risk of severe injury and rendering the environment liable to contamination.

Precautions:

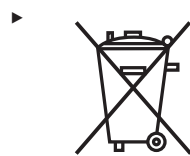

The product must not be disposed with household waste. Dispose of the product appropriately in accordance with the national regulations in force in your country. Always prevent access to the product by unauthorised personnel.

Product-specific treatment and waste management information can be received from your Leica Geosystems distributor.

⚠ WARNING

Improperly repaired equipment

Risk of injuries to users and equipment destruction due to lack of repair knowledge.

Precautions:

- ▶ Only authorised Leica Geosystems Service Centres are entitled to repair these products.

Description

The term Electromagnetic Compatibility is taken to mean the capability of the product to function smoothly in an environment where electromagnetic radiation and electrostatic discharges are present, and without causing electromagnetic disturbances to other equipment.

⚠ CAUTION**Electromagnetic radiation**

Electromagnetic radiation can cause disturbances in other equipment.

Precautions:

- ▶ Although the product meets the strict regulations and standards which are in force in this respect, Leica Geosystems cannot completely exclude the possibility that other equipment may be disturbed.

⚠ CAUTION**Use of the product with accessories from other manufacturers. For example, field computers, personal computers or other electronic equipment, non-standard cables or external batteries**

This may cause disturbances in other equipment.

Precautions:

- ▶ Use only the equipment and accessories recommended by Leica Geosystems.
- ▶ When combined with the product, other accessories must meet the strict requirements stipulated by the guidelines and standards.
- ▶ When using computers, two-way radios or other electronic equipment, pay attention to the information about electromagnetic compatibility provided by the manufacturer.

⚠ CAUTION**Intense electromagnetic radiation. For example, near radio transmitters, transponders, two-way radios or diesel generators**

Although the product meets the strict regulations and standards which are in force in this respect, Leica Geosystems cannot completely exclude the possibility that the function of the product may be disturbed in such an electromagnetic environment.

Precautions:

- ▶ Check the plausibility of results obtained under these conditions.

CAUTION

Electromagnetic radiation due to improper connection of cables

If the product is operated with connecting cables, attached at only one of their two ends, the permitted level of electromagnetic radiation may be exceeded and the correct functioning of other products may be impaired. For example, external supply cables or interface cables.

Precautions:

- ▶ While the product is in use, connecting cables, for example product to external battery or product to computer, must be connected at both ends.
-

WARNING

Use of product with radio or digital cellular phone devices

Electromagnetic fields can cause disturbances in other equipment, installations, medical devices, for example pacemakers or hearing aids, and aircrafts. Electromagnetic fields can also affect humans and animals.

Precautions:

- ▶ Although the product meets the strict regulations and standards which are in force in this respect, Leica cannot completely exclude the possibility that other equipment can be disturbed or that humans or animals can be affected.
 - ▶ Do not operate the product with radio or digital cellular phone devices in the vicinity of filling stations or chemical installations, or in other areas where an explosion hazard exists.
 - ▶ Do not operate the product with radio or digital cellular phone devices near medical equipment.
 - ▶ Do not operate the product with radio or digital cellular phone devices in aircrafts.
 - ▶ Do not operate the product with radio or digital cellular phone devices for long periods with the product immediately next to your body.
-

11

System Components

Support of AutoPole functionality

Term	Description
PoleHeight	Automatically measure height or length from the pole tip to the reflector and apply it to field software.
Tilt Compensation	Seamlessly measure and layout points with an arbitrary tilted reflector pole. Constantly show the quality of tilt compensated points in the field and store it with the point.
TargetID	Search and lock onto the target by verifying a specific ID on the fly.

	iCR80	iCR70	iCR80S
PoleHeight	✓	✓	✓
Tilt Compensation*	✓	✓	✓
TargetID	✓	✓	✓

* Requires CCD18 or RH18 attached to iCR instrument

12

Setting Up AutoPole

AutoPole setup

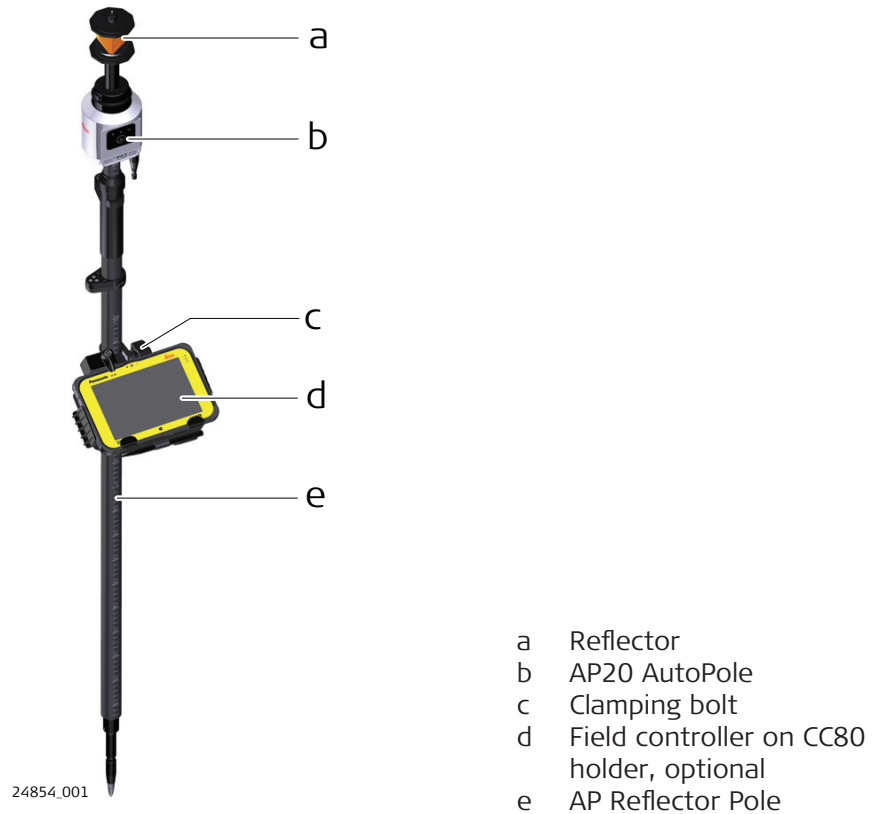

Attaching AP20 onto AP Reflector Pole



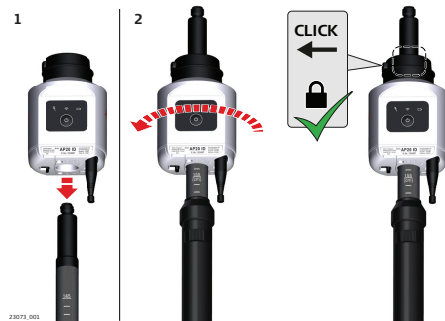

AP20 is only compatible with AP reflector poles CRP4, CRP5, GLS51 and GLS51F.



1. Place the AP20 over the top of the AP reflector pole and slide it down as far as it will go.
2. Rotate the AP20 until it snaps into one of the lock positions.
3. To remove the AP20, press in the lock button to release it, then slide it up and off the top of the AP reflector pole.

Pole handling

	Standard use	Reversed use CRP10 attached on reflector		
				
		<ul style="list-style-type: none"> a GLS51 b MPR122 c GRZ122 d CRP10 with optional CRP13* 		
PoleHeight**	✓	–		
Tilt Compensation**	✓	✓ Refer to the manual of the field software for information about the setting.		
TargetID**	✓	✓		
*	Feet adapter for the CRP10 tip			
**	Features depending on AP20 variant			
	For reversed use, the target height must be entered manually.			
Reflector	Target height with exchangeable pole tip			
	CRP10		CRP10 + CRP13	
Unit	[m]	[ft]	[m]	[ft]
MPR122	0.200	0.656	0.305	1.000
GRZ122	0.228	0.748	0.333	1.093

13

Battery for the AP20

Change battery step-by-step



GEB321 batteries must be used in the AP20. GEB211/GEB212 do NOT work with AP20.

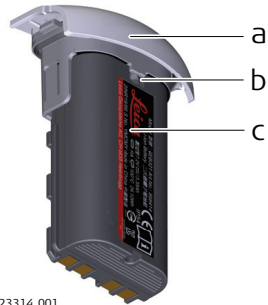

23314.001

- a Battery holder
- b Notch of battery holder
- c Battery GEB321



23315.001

1. Push the slide fastener of the battery holder in the direction of the arrow with the open-lock symbol.
2. Remove the battery holder from the compartment. Remove the battery from the holder.
3. To insert the battery, attach the battery to the batter holder. Align the battery to fit notch of battery holder.
4. Insert the battery holder into the compartment.
5. Push the slide fastener in the direction of the arrow with the close-lock symbol.

Software upload

In case a software upload for AP20 is indicated, the correct firmware file has to be selected. The firmware file depends on the AP20 model.

Model	Software type
AP20 H	AP20H_ID_Firmware.swu
AP20 ID	Covers all functions required.
AP20 T	AP20_T_Firmware.swu
AP20	Covers all functions required.



Uploading software can take some time. Ensure that the battery is at least 20% full before you start the upload. Do not remove the battery during the upload process.

Software update instructions for all AP20 models:

1. Download the most recent firmware file from <https://myworld.leica-geosystems.com> to your local PC.
2. Connect AP20 to PC using GEV284 cable.
3. Copy the firmware file onto the AP20 memory device.
4. Disconnect GEV284 cable.
5. Switch AP20 off.
6. Switch AP20 on.
7. The upload starts automatically. During the upload, all three LEDs are flashing consecutively.
8. The update is complete when the Power LED on AP20 is constantly lit.

15

Working with the AutoPole

15.1

Overview

AutoPole functionality

Functionalities are listed according to the individual sales variants.

Functionality	AP20 H	AP20 ID	AP20 T	AP20
PoleHeight	✓	–	✓	✓
Tilt Compensation	–	–	✓	✓
TargetID	–	✓	–	✓

- ✎ AP20 can only be used in combination with an AP Reflector Pole (CRP4, CRP5, GLS51 and GLS51F).
- ✎ Establish a Bluetooth connection between the AP20 and the field controller or the total station in order to be operative. Use the connection wizard.

Supported connection types

Supported

AP20 (all variants) with TPS

- ✎ A robotic TPS must be connected to a controller first. Then connect to AP20.

Instrument	iCR80		iCR80S		iCR70	
	CCD6	CCD18	CCD6	CCD18	CCD6	CCD18
AP20 AP20 T	–	✓	–	✓	–	✓
AP20 H AP20 ID	✓	✓	✓	✓	✓	✓

TS16 and MS60 can also be used.

Not supported

- AP20 (all variants) with GNSS (no PoleHeight)
- Onboard use case

15.2

PoleHeight

Description

The AP Reflector Pole can be extended to any of the given snap-lock positions in order to overcome obstacles.

As soon as a snap-lock position is reached, the attached AP20 receives the detected height from the AP Reflector Pole and transmits it to the field software of the connected total station or field controller.

The transmitted height corresponds to the current length between prism centre and pole tip, which is equivalent to the printed scale on the pole and the height input field within the field software.

- ✎ Valid height detection is limited to the snap-lock positions. Intermediate positions are indicated as invalid. Enter the height manually.
- ✎ Optional pole extensions are not taken into account.

Diagram

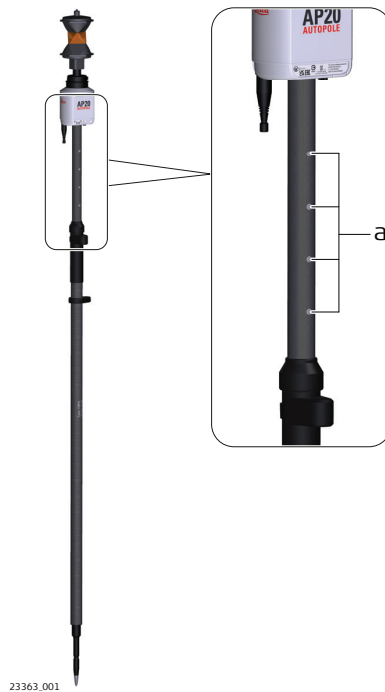

a Snap-lock positions

PoleHeight step-by-step

Action	Result
<p>☞ PoleHeight is only supported with sales variants AP20 H, AP20 T and AP20.</p>	
<p>☞ PoleHeight can be used if the controller is connected to a robotic TPS instrument.</p>	
<p>☞ When using an AP20 T, an AP20 H or an AP20 make sure that AutoPole is selected as prism type.</p>	
<p>1. In any app: Open the Controller/Target container from the status bar.</p>	<p>The screenshot shows the 'Controller/Target' container in an application. The 'Pole Height' icon is highlighted in the center of the container. Other icons include 'Prism Type', 'Turn to point', 'Battery & Settings', 'Blow & Search', 'Search Settings', 'Search Station', 'Target Sleep', and 'Take out targets'.</p>
<p>2. Tap Prism Height.</p>	
<p>3. To turn PoleHeight ON: Tap on the Auto height feature. To turn PoleHeight OFF: Select any predefined height or enter the height manually.</p>	<p>The screenshot shows the 'Pole Height' settings screen. The 'Auto height' feature is highlighted in yellow. Below it, there are predefined height options: 0.000, 0.200, 0.500, 1.000, and 2.000. A text input field at the bottom is labeled 'Enter auto pole height: 2.000'.</p>
<p>4. Extend or compress the pole physically to overcome obstacles.</p>	

Action	Result
5. If Auto height is used, the correct value is displayed in the status bar.	
6. Measure or stake a point. The current height is applied to the coordinate calculation.	

15.3

Tilt Compensation

Description

The AP Reflector Pole can be held in a slanting position over the point to be measured without checking the circular bubble on the pole.

When measuring a point, the pole tip must be stable on the point while the pole should be in slight movement. Tilt compensation is indicated by an icon and the Tilt LED and is maintained by natural pole movement, for example while moving to the next point to be measured.









Measurements are reliable and accurate even if the pole is not levelled as the tilt values are calculated by an Inertial Measurement Unit. Tilt values contain information about the 3D position of the pole.

Diagram

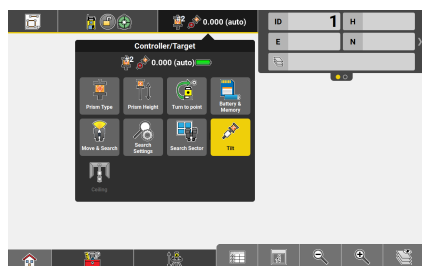

Tilt Compensation step-by-step

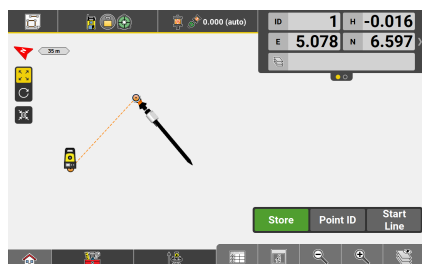
Action	Result
 Tilt Compensation is only supported with sales variants AP20 T and AP20 when the controller is connected to a robotic total station via CCD18.	

Action	Result
 Tilt Compensation can be used if the controller is connected to a robotic TPS instrument.	
1. In any app: Open the Controller/Target container from the status bar.	
2. Tap Prism Type .	
3. Select AutoPole .	
4. To turn Tilt Compensation ON or OFF: Tap on the Controller/Target container and select Tilt .	
 Tilt Compensation is not supported within the Setup, Sets of Angles and 2-Face app.	
 Ceiling becomes available for selection when Tilt Compensation is ON.	
Tap on the Controller/Target container and select  in order to automatically measure the point on the ceiling, no matter how the pole is tilted.	
5. Tap Start in the measure bar.	
6. Move the pole for initialisation. Walking to the layout point is sufficient. The Start button changes to a green Store to indicate that the tilt compensation is being applied.	
 The Tilt LED on the AP20 and the symbol for the pole in the status bar indicate when a tilt compensated measurement is possible. Refer to 16 LED Indicators .	
7. Measure or stake a point.	

15.4

TargetID

Description

TargetID provides an automatic target search and identification on-the-fly. The common search methods, such as PowerSearch, are extended with an additional verification of an ID which is transmitted from the AP20.

While the total station is performing a search, it ignores any other target or foreign reflections and only stops and locks onto the target above the AP20.

Diagram



a TargetID window, 360° coverage

TargetID step-by-step

Action	Result
TargetID is only supported with sales variants AP20 ID and AP20.	
TargetID can be used if the controller is connected to a robotic TPS instrument.	
1. In any app: Open the Controller/Target container from the status bar.	
2. Tap Prism Type .	
3. To turn the TargetID ON: Select AutoPole as prism type from the status bar. To turn the TargetID OFF: Select any pre-defined or user defined prism, except AutoPole .	
4. Start a prism search.	
The search includes identification on-the-fly and only stops at and locks onto the target above the AP20.	

16

LED Indicators

Description of the AP20 ON/OFF button and status LEDs

Diagram



- a Tilt Compensation LED
- b Connectivity LED
- c Power LED
- d ON/OFF button

Description of the LED Indicators

LED	LED Status	Status of the Instrument
Tilt Compensation LED	off	Tilt compensation is unavailable or switched off.
	green	Tilt compensation is activated, compensation values are stored. Tilt compensation is being applied to the point measurement.
	red	Tilt compensation is activated, but currently not being applied to the point measurement.
Connectivity LED	off	AP20 is not powered or module is not ready.
	green	Bluetooth is visible for other instruments and ready for connecting.
	blue	Bluetooth has connected.
Power LED	off	Battery is not connected, flat or AP20 is switched off.
	green	Power is 21% - 100%.
	red	Power is 11% - 20%. The remaining time for which enough power is available depends on the type of survey, the temperature and the age of the battery.
	flashing red	Power is low (<10%).

17 Care and Transport

17.1 Transport

Transport in the field When transporting the equipment in the field, always make sure that you carry the product in its original container.

Transport in a road vehicle Never carry the product loose in a road vehicle, as it can be affected by shock and vibration. Always carry the product in its container and secure it.
For products for which no container is available use the original packaging or its equivalent.

Shipping When transporting the product by rail, air or sea, always use the complete original Leica Geosystems packaging, container and cardboard box, or its equivalent, to protect against shock and vibration.

Shipping, transport of batteries When transporting or shipping batteries, the person responsible for the product must ensure that the applicable national and international rules and regulations are observed. Before transportation or shipping, contact your local passenger or freight transport company.

17.2 Storage

Product Respect the temperature limits when storing the equipment, particularly in summer if the equipment is inside a vehicle. Refer to [18 Technical Data](#) for information about temperature limits.

Li-Ion batteries

- Refer to [18 Technical Data](#) for information about storage temperature range
- Remove batteries from the product and the charger before storing
- After storage recharge batteries before using
- Protect batteries from damp and wetness. Wet or damp batteries must be dried before storing or use
- A storage temperature range of 0 °C to +30 °C / +32 °F to +86 °F in a dry environment is recommended to minimize self-discharging of the battery
- At the recommended storage temperature range, batteries containing a 40% to 50% charge can be stored for up to one year. After this storage period the batteries must be recharged

17.3 Cleaning and Drying

Product and accessories

- Use only a clean, soft, lint-free cloth for cleaning. If necessary, moisten the cloth with water or pure alcohol. Do not use other liquids; these may attack the polymer components.

Damp products Dry the product, the transport container, the foam inserts and the accessories at a temperature not greater than 40 °C /104 °F and clean them. Remove the battery cover and dry the battery compartment. Do not repack until everything is completely dry. Always close the transport container when using in the field.

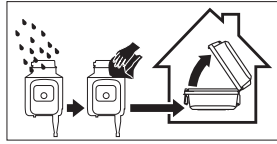

AP reflector pole

In case of water ingress in the AP reflector pole, remove the tip of the pole to release water.

Cables and plugs

Keep plugs clean and dry. Blow away any dirt lodged in the plugs of the connecting cables.

18

Technical Data



18.1

PoleHeight

Range	AP Reflector Pole	PoleHeight Minimum		PoleHeight Maximum		Snap-lock spacing	
		[m]	[ft]	[m]	[ft]	[m]	[ft]
	CRP4	1.55	-	2.20	-	0.05	-
	CRP5	-	6.0	-	7.0	-	1.0
	GLS51	1.55	-	2.20	-	0.05	-
	GLS51F	-	4.7	-	7.0	-	0.2

Accuracy in reading of PoleHeight

± 1.0 mm

-  Valid for engaged snap-lock positions of the AP Reflector Pole.
-  The centring accuracy of the attached prism is not included.

18.2

Tilt Compensation



Range

Tilt range

Tilt Compensation works in arbitrary alignments of the pole as long as the target has free line-of-sight to the total station and positions can be measured continuously.

Range from total station

The maximum measuring range between the tilted pole and the total station depends on the achievable target lock and the remote connection range, typically 300 m.

-  A total station with target locking and continuous distance measurement is required.
-  A RH18 or CCD18 is required on the total station to support AP20 Tilt Compensation.

Accuracy

Since the Tilt Compensation uses continuous total station observations for the determination of the pole tilt, the tilt accuracy depends on various factors.

- Angular accuracy of the total station
- Distance accuracy of the total station
- Target type
- EDM measurement frequency of the total station
- Environmental and atmospheric conditions
- Target height
- Level of pole tilt

The derived additional pole tip accuracy in 2D and 1D, given as root mean square, depends on the level of tilt and the used target height. The lower the target height, the higher the pole tip accuracy.

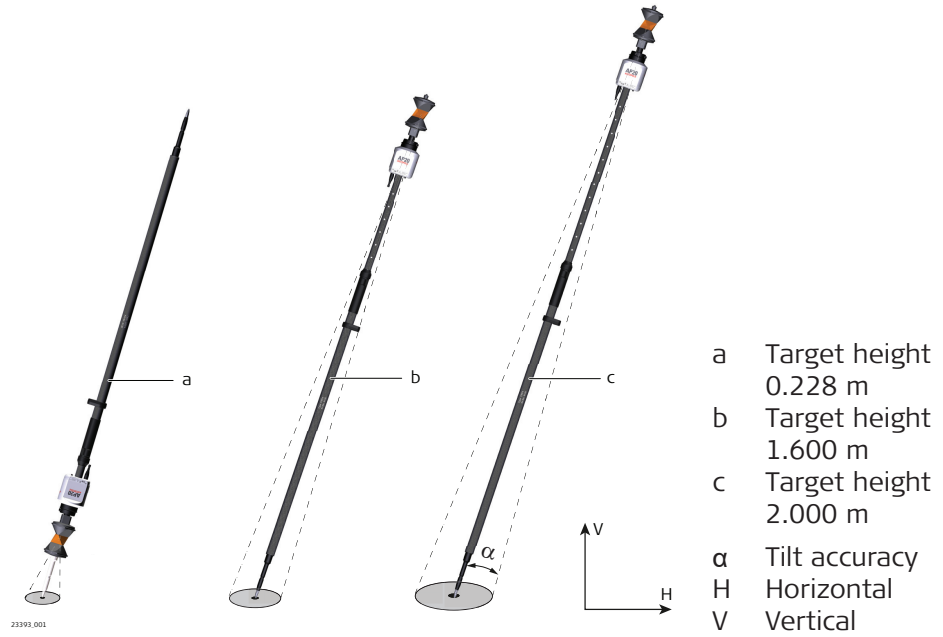

The less the pole is tilted from zenith/nadir to a horizontal pole alignment, the higher the pole tip accuracy.

	Target height	Additional pole tip uncertainty for tilt down to 90°, typically
Horizontal (2D)	0.228 m	1 mm + 0.1 mm/° tilt
	1.600 m	3 mm + 0.6 mm/° tilt
	2.000 m	4 mm + 0.7 mm/° tilt
Vertical (1D)	0.228 m	1 mm + 0.05 mm/° tilt
	1.600 m	1 mm + 0.05 mm/° tilt
	2.000 m	1 mm + 0.1 mm/° tilt

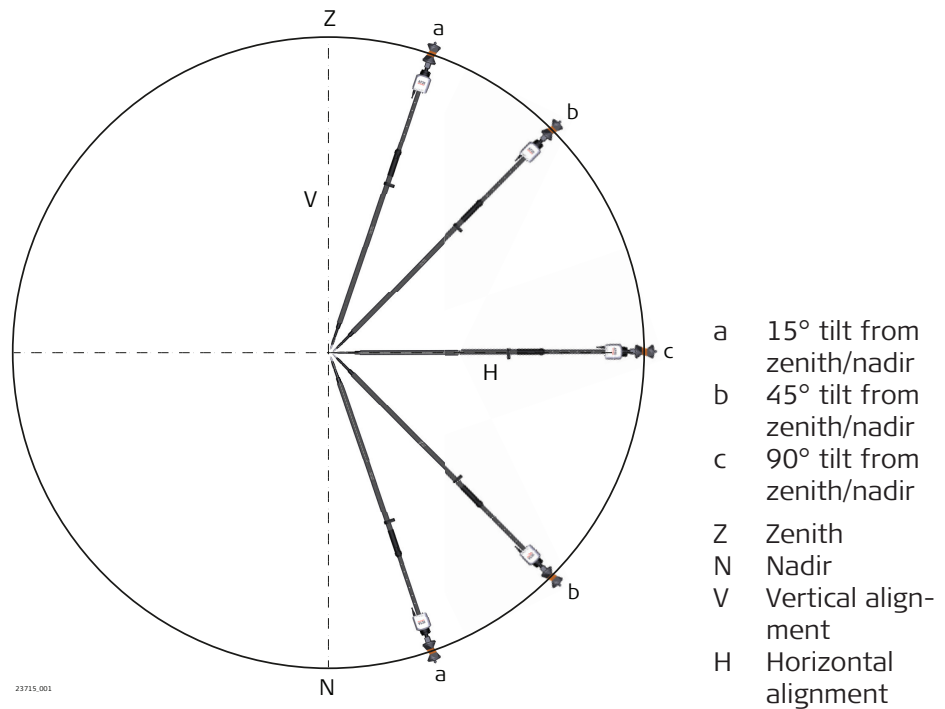

When carrying the AP20 on the pole:

- Avoid dropping it and toppling over.
- In case of mechanic shock, test measurements are recommended to check the accuracy.

Measurement principle

Combining the reflector position with attitude information from an Inertial Measurement Unit (IMU) results in a tilt compensated pole tip position.

18.3

TargetID

Range

Pole alignment	Range	
	[m]	[ft]
Vertical	150	500
Tilted $\pm 30^\circ$	100	325

TargetID uses PowerSearch technology. Measurements at the vertical limits of the PowerSearch fan or under unfavourable atmospheric conditions may reduce the maximum range.

Shortest measuring distance: 3 m

Separability

Number of different IDs: 16

Principle of TargetID

Type	Description
Principle	Digital image processing
Type	Infrared laser

A total station with PowerSearch is required.

18.4

General Technical Data of the Product

AP20 dimensions



Weight

Type	Value
All AP20	0.4 kg
Internal battery	0.1 kg

Power consumption

Type	Power consumption	
	Typically	Maximum
AP20 H	1.2 W	1.5 W
AP20 ID	1.5 W	13.1 W
AP20 T	3.2 W	4.0 W
AP20	3.6 W	15.6 W

Instrument port

Name	Description
USB type C port	Cable connection from USB devices for firmware update

Internal battery

Type	Battery	Nominal Voltage	Capacity
GEB321	Li-Ion	7.2 V \approx	3.35 Ah

Operating times

Model	Operating time, typical
AP20 H	> 16 h
AP20 ID	

Environmental specifications

Model	Operating time, typical
AP20 T AP20	6 h

Temperature

Type	Operating temperature [°C]	Storage temperature [°C]
All AP20	-30 to +60	-40 to +80

Protection against water, dust and sand

Protection	
All AP20	IP67 (IEC 60529)

Humidity

Type	Protection
All AP20	Max 95% non condensing The effects of condensation are to be effectively counteracted by periodically drying out the AP20.

18.5

Conformity to National Regulations

Labelling AP20

23394_001

Made in Singapore Model: **AP20 ID** Leica Geosystems AG
 Manufactured: XX.20XX S. No.: 1234567 CH-9435 Heerbrugg
 Power: 12-18V = Ah max Article No.: 1234567
 IP67

UK CA EAC R203-JN122 R3C319 YU10458-16004 전지 This device contains a transmitter:
 FCC ID: XPYNINAB22
 IC: 8595A-NINAB22
 CMIIT ID XXXXYZNNNN
 A/S: +82 31 620 6252

This device complies with part 15 of the FCC Rules. Operation is subject to the following two conditions: (1) This device may not cause harmful interference, and (2) this device must accept any interference received, including interference that may cause undesired operation.

24805_001

Labelling GEB321

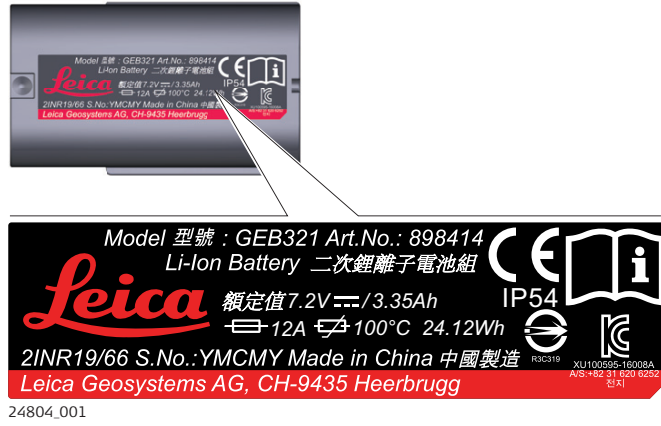

Frequency band

Type	Value
Bluetooth	2402 - 2480 MHz
NFC	13.56 MHz

Output power

Type	Value
Bluetooth	≤ 8 dBm (e.i.r.p)

Antenna

Type	Antenna	Gain
Bluetooth Classic	Planar Inverted-F Antenna (PIFA)	Internal antenna
Bluetooth Low Energy	1/4 wavelength whip antenna	3.5 dBi (Peak)
Near-Field Communication (NFC)	Coil flex	-

EU



Hereby, Leica Geosystems AG declares that the radio equipment type AP20 is in compliance with Directive 2014/53/EU and other applicable European Directives. The full text of the EU declaration of conformity is available at the following Internet address: <http://www.leica-geosystems.com/ce>.

USA

Contains FCC ID: XPYNINAB22 (AP20 H), XPYNINAB22 (AP20 ID), RFD-AP20T (AP20 T), RFD-AP20T (AP20) Part 15 B

This device complies with part 15 of the FCC Rules. Operation is subject to the following two conditions:

1. This device may not cause harmful interference, and
2. This device must accept any interference received, including interference that may cause undesired operation.

This equipment has been tested and found to comply with the limits for a Class B digital device, pursuant to part 15 of the FCC Rules.

These limits are designed to provide reasonable protection against harmful interference in a residential installation.

This equipment generates, uses, and can radiate radio frequency energy and, if not installed and used in accordance with the instructions, it may cause harmful interference to radio communications.

However, there is no guarantee that interference does not occur in a particular installation.

If this equipment does cause harmful interference to radio or television reception, which can be determined by turning the equipment off and on, the user is encouraged to try to correct the interference by one or more of the following measures:

- Reorient or relocate the receiving antenna.
- Increase the separation between the equipment and the receiver.
- Connect the equipment into an outlet on a circuit different from that to which the receiver is connected.
- Consult the dealer or an experienced radio/TV technician for help.

Canada

CAN ICES-003 B/NMB-003 B
IC: 8595A-NINAB22 (AP20 H), 8595A-NINAB22 (AP20 ID), 3177A-AP20T (AP20 T), 3177A-AP20T (AP20)

Canada Compliance Statement

This device contains licence-exempt transmitter(s)/receiver(s) that comply with Innovation, Science and Economic Development Canada's licence-exempt RSS(s). Operation is subject to the following two conditions:

1. This device may not cause interference
2. This device must accept any interference, including interference that may cause undesired operation of the device

Canada Déclaration de Conformité

L'émetteur/récepteur exempt de licence contenu dans le présent appareil est conforme aux CNR d'Innovation, Sciences et Développement économique Canada applicables aux appareils radio exempts de licence. L'exploitation est autorisée aux deux conditions suivantes:

1. L'appareil ne doit pas produire de brouillage
2. L'appareil doit accepter tout brouillage radioélectrique subi, même si le brouillage est susceptible d'en compromettre le fonctionnement

Japan

- This device is granted pursuant to the Japanese Radio Law (電波法).
- This device should not be modified (otherwise the granted designation number will become invalid).

Others

The conformity for countries with other national regulations has to be approved prior to use and operation.

Software Licence Agreement

This product contains software that is preinstalled on the product, or that is supplied to you on a data carrier medium, or that can be downloaded by you online according to prior authorisation from Leica Geosystems. Such software is protected by copyright and other laws and its use is defined and regulated by the Leica Geosystems Software Licence Agreement, which covers aspects such as, but not limited to, Scope of the Licence, Warranty, Intellectual Property Rights, Limitation of Liability, Exclusion of other Assurances, Governing Law and Place of Jurisdiction. Please make sure, that at any time you fully comply with the terms and conditions of the Leica Geosystems Software Licence Agreement.

Such agreement is provided together with all products and can also be referred to and downloaded at the Leica Geosystems home page at [Hexagon – Legal Documents](#) or collected from your Leica Geosystems distributor.

You must not install or use the software unless you have read and accepted the terms and conditions of the Leica Geosystems Software Licence Agreement. Installation or use of the software or any part thereof, is deemed to be an acceptance of all the terms and conditions of such Licence Agreement. If you do not agree to all or some of the terms of such Licence Agreement, you must not download, install or use the software and you must return the unused software together with its accompanying documentation and the purchase receipt to the distributor from whom you purchased the product within ten (10) days of purchase to obtain a full refund of the purchase price.

Open Source information

The software on the product may contain copyright-protected software that is licenced under various open source licences.

Copies of the corresponding licences

- are provided together with the product (for example in the About panel of the software)
- can be downloaded on <http://opensource.leica-geosystems.com>

If foreseen in the corresponding open source licence, you may obtain the corresponding source code and other related data on <http://opensource.leica-geosystems.com>.

Contact

opensource@leica-geosystems.com in case you need additional information.

871949-3.0.0en

Original text

Published in Switzerland, © 2022 Leica Geosystems AG



- when it has to be **right**



Leica Geosystems AG

Heinrich-Wild-Strasse
9435 Heerbrugg
Switzerland

www.leica-geosystems.com

