

# Leica Rugby CLAx



User Manual  
Version 1.1  
English

- when it has to be **right**

**Leica**  
Geosystems

PART OF  
**HEXAGON**

# Introduction

## Purchase

Congratulations on the purchase of a Leica Rotating Laser product.



This manual contains important safety directions as well as instructions for setting up the product and operating it. Refer to **1 Safety Directions** for further information.

Read carefully through the User Manual before you switch on the product.



The content of this document is subject to change without prior notice. Ensure that the product is used in accordance with the latest version of this document.

Updated versions are available for download at the following Internet address:  
<https://myworld-portal.leica-geosystems.com/> > myDownloads



## Product identification

The model and serial number of your product are indicated on the type label. Always refer to this information when contacting your agency or Leica Geosystems authorised service centre.

## Validity of this manual

This manual applies to the Rugby lasers. Differences between the models are marked and described.

## Available documentation

Name	Description/Format		
Rugby Quick Guide	Provides an overview of the product. Intended as a quick reference guide.	✓	✓
Rugby User Manual	All instructions required in order to operate the product to a basic level are contained in the User Manual. Provides an overview of the product together with technical data and safety directions.	-	✓

### Refer to the following resources for all Rugby documentation/software:

- the Leica Rugby CD
- <https://myworld-portal.leica-geosystems.com/>



<https://myworld-portal.leica-geosystems.com/> offers a wide range of services, information and training material.

With direct access to myWorld, you are able to access all relevant services whenever it is convenient for you.

The availability of services depends on the instrument model.

Service	Description
My Products	Register all products that you and your company own and explore your world of Leica Geosystems: View detailed information on your products and update your products with the latest software and keep up-to-date with the latest documentation.

Service	Description
My Service	View the current service status and full service history of your products in Leica Geosystems service centres. Access detailed information on the services performed and download your latest calibration certificates and service reports.
My Support	Create new support requests for your products that will be answered by your local Leica Geosystems support team. View your complete support history and view detailed information on all your support requests.
Knowledge	Enter key words and start searching in our knowledge base. You can find FAQs (Frequently asked questions) as well as Knowledge articles for Leica Geosystems products.
Downloads	Downloads of software, manuals, tools, training material and news for Leica Geosystems products. Download the latest documentation and software to keep yourself and your products up-to-date. You can access downloads of software, manuals, tools, and training material.
Online Learning	Welcome to the home of Leica Geosystems online learning! There are numerous online courses – available to all customers with products that have valid CCPs (Customer Care Packages).
My SmartNet	Add and view your HxGN SmartNet subscriptions and user information. HxGN SmartNet delivers high-precision and high-availability GNSS network correction services in real-time and around the globe. The HxGN SmartNet Global family offers Network RTK with RTK bridging and Precise Point Positioning (PPP) services. These services work exclusively with Leica Geosystems GS smart antennas and receivers, providing the highest accuracy. Combined, they ensure HxGN SmartNet coverage everywhere.
My Trusted Services	Leica Geosystems Trusted Services offer you increased productivity while at the same time providing maximum security. New software services and state-of-the-art IT infrastructure offer a vast potential to optimise your workflow and increase your efficiency and productivity, both now and in the future.
My Security	Leica Geosystems Security delivers you total peace-of-mind in knowing that if your instrument is ever stolen, a locking mechanism is available to ensure that the instrument is disabled and can no longer be used.

### Calibration Certificate

Calibration Certificates are available in the following formats:

- Rugby CLAx Certificate Silver can be found printed in every carry case.

# Table of Contents

<b>1</b>	<b>Safety Directions</b>	<b>6</b>
1.1	General	6
1.2	Definition of Use	7
1.3	Limits of Use	7
1.4	Responsibilities	7
1.5	Hazards of Use	8
1.6	Laser Classification	13
	1.6.1 General	13
	1.6.2 Rugby CLAx	14
1.7	Electromagnetic Compatibility (EMC)	15
<b>2</b>	<b>Description of the System</b>	<b>17</b>
2.1	System Components	17
2.2	Product Variants	18
2.3	Rugby Laser Components	20
2.4	Case Components	20
2.5	Setup	20
<b>3</b>	<b>Operation</b>	<b>22</b>
3.1	Control Panel	22
3.2	Turning the Rugby On and Off	22
3.3	The LCD Display	22
3.4	Axis Identification	24
3.5	Conversion of Slope Into Percent of Grade	24
3.6	Alignment of the Axes	24
3.7	Precise Alignment of the Axes	25
3.8	Grade Entry	26
	3.8.1 Grade Entry with Combo+	26
	3.8.2 Grade Entry with Rugby CLAx	28
3.9	Vertical Operation	29
<b>4</b>	<b>Combo+</b>	<b>30</b>
4.1	Description of the Combo+	30
4.2	Connecting Screens for the Combo+	32
4.3	Combo+ Menu	32
	4.3.1 Access and Navigation	32
	4.3.2 Menu Set 1	35
	4.3.3 Menu Set 2	41
	4.3.4 Grade Entry	44
<b>5</b>	<b>The Rod Eye Receivers</b>	<b>49</b>
5.1	Rod Eye 120, Receiver	49
5.2	Rod Eye 140, Classic Receiver	50
5.3	Rod Eye 160, Digital Receiver	51
<b>6</b>	<b>Applications</b>	<b>52</b>
6.1	Setting Forms	52
6.2	Checking Grades	53
6.3	Manual Grades	54
	6.3.1 Manual Grades	54
	6.3.2 Manual Grades with Slope Adapter	55
6.4	Batter Boards	55
6.5	Suspended Ceilings	58
6.6	Layout	59
6.7	Layout with Slope Catch	61

6.8			
	6.8.1	Grade Dial-in with Combo+	62
	6.8.2	Grade Dial-in with Rugby CLAx	63
6.9		Slope Catch	63
6.10		Slope Lock	64
6.11		Automatic Axis Alignment	65
6.12		Axis Alignment plus Slope Lock	68
6.13		Dual Combo+ Setups	68
6.14		More Applications	68
<b>7</b>	<b>Batteries</b>		<b>70</b>
7.1		Battery for Rugby	70
7.2		Battery for Combo+	72
<b>8</b>	<b>Accuracy Adjustment</b>		<b>73</b>
8.1		Checking the Self-Levelling Accuracy	73
8.2		Adjusting the Self-Levelling Accuracy	74
8.3		Adjusting the Vertical Accuracy	76
<b>9</b>	<b>Semi-Automatic Calibration</b>		<b>77</b>
<b>10</b>	<b>Troubleshooting</b>		<b>81</b>
<b>11</b>	<b>Care and Transport</b>		<b>87</b>
11.1		Transport	87
11.2		Storage	87
11.3		Cleaning and Drying	87
<b>12</b>	<b>Technical Data</b>		<b>89</b>
12.1		Conformity to National Regulations	89
	12.1.1	Products with Radio Transmitter/Receiver	89
	12.1.2	Products without Radio	91
12.2		General Technical Data of the Product	92
<b>13</b>	<b>Lifetime Manufacturer's Warranty</b>		<b>95</b>
13.1		Rugby	95
13.2		Combo+	95
<b>14</b>	<b>Accessories</b>		<b>96</b>

# 1 Safety Directions

## 1.1 General

### Description

The following directions enable the person responsible for the product, and the person who actually uses the equipment, to anticipate and avoid operational hazards.

The person responsible for the product must ensure that all users understand these directions and adhere to them.

### About warning messages





Warning messages are an essential part of the safety concept of the instrument. They appear wherever hazards or hazardous situations can occur.

#### Warning messages...

- make the user alert about direct and indirect hazards concerning the use of the product.
- contain general rules of behaviour.

For the users' safety, all safety instructions and safety messages shall be strictly observed and followed! Therefore, the manual must always be available to all persons performing any tasks described here.

**DANGER, WARNING, CAUTION** and **NOTICE** are standardised signal words for identifying levels of hazards and risks related to personal injury and property damage. For your safety, it is important to read and fully understand the following table with the different signal words and their definitions! Supplementary safety information symbols may be placed within a warning message as well as supplementary text.

Type	Description
 <b>DANGER</b>	Indicates an imminently hazardous situation which, if not avoided, will result in death or serious injury.
 <b>WARNING</b>	Indicates a potentially hazardous situation or an unintended use which, if not avoided, could result in death or serious injury.
 <b>CAUTION</b>	Indicates a potentially hazardous situation or an unintended use which, if not avoided, may result in minor or moderate injury.
 <b>NOTICE</b>	Indicates a potentially hazardous situation or an unintended use which, if not avoided, may result in appreciable material, financial and environmental damage.
	Important paragraphs which must be adhered to in practice as they enable the product to be used in a technically correct and efficient manner.

### Additional symbols



Warning against flammable substances.



Warning against explosive material.



Product must not be opened or modified or tampered with.



Indicates the temperature limits at which the product may be stored, transported or used.

## 1.2

### Definition of Use

#### Intended use

- The laser beam can be detected by means of a laser detector
- Remote control of product
- Data communication with external appliances

#### Reasonably foreseeable misuse

- Use of the product without instructions
- Use outside of the intended use and limits
- Disabling of safety systems
- Removal of hazard notices
- Opening the product using tools, for example a screwdriver, unless this is permitted for certain functions
- Modification or conversion of the product
- Use after misappropriation
- Use of products with recognisable damage or defects
- Use with accessories from other manufacturers without the prior explicit approval of Leica Geosystems
- Inadequate safeguards at the working site
- Deliberate dazzling of third parties
- Controlling of machines, moving objects or similar monitoring applications without additional control and safety installations

## 1.3

### Limits of Use

#### Environment

Suitable for use in an atmosphere appropriate for permanent human habitation. Not suitable for use in aggressive or explosive environments.

#### **WARNING**

#### **Working in hazardous areas or close to electrical installations or similar situations**

Life Risk.

#### **Precautions:**

- ▶ Local safety authorities and safety experts must be contacted by the person responsible for the product before working in such conditions.

## 1.4

### Responsibilities

#### Manufacturer of the product

Leica Geosystems AG, CH-9435 Heerbrugg, hereinafter referred to as Leica Geosystems, is responsible for supplying the product, including the User Manual and original accessories, in a safe condition.

## Person responsible for the product

The person responsible for the product has the following duties:

- To understand the safety instructions on the product and the instructions in the User Manual
- To ensure that the product is used in accordance with the instructions
- To be familiar with local regulations relating to safety and accident prevention
- To stop operating the system and inform Leica Geosystems immediately if the product and the application become unsafe
- To ensure that the national laws, regulations and conditions for the operation of the products are respected

## 1.5

### Hazards of Use

#### NOTICE

#### **Dropping, misusing, modifying, storing the product for long periods or transporting the product**

Watch out for erroneous measurement results.

#### **Precautions:**

- ▶ Periodically carry out test measurements and perform the field adjustments indicated in the User Manual, particularly after the product has been subjected to abnormal use as well as before and after important measurements.

#### **DANGER**

#### **Risk of electrocution**

Because of the risk of electrocution, it is dangerous to use poles, levelling staffs and extensions in the vicinity of electrical installations such as power cables or electrical railways.

#### **Precautions:**

- ▶ Keep at a safe distance from electrical installations. If it is essential to work in this environment, first contact the safety authorities responsible for the electrical installations and follow their instructions.



#### NOTICE

#### **Remote control of product**

With the remote control of products, it is possible that extraneous targets will be picked out and measured.

#### **Precautions:**

- ▶ When measuring in remote control mode, always check your results for plausibility.

## **WARNING**

### **Lightning strike**

If the product is used with accessories, for example masts, staffs, poles, you may increase the risk of being struck by lightning.

#### **Precautions:**

- ▶ Do not use the product in a thunderstorm.
- 

## **WARNING**

### **Inadequate securing of the working site**

This can lead to dangerous situations, for example in traffic, on building sites and at industrial installations.

#### **Precautions:**

- ▶ Always ensure that the working site is adequately secured.
  - ▶ Adhere to the regulations governing safety, accident prevention and road traffic.
- 

## **CAUTION**

### **Not properly secured accessories**

If the accessories used with the product are not properly secured and the product is subjected to mechanical shock, for example blows or falling, the product may be damaged or people can sustain injury.

#### **Precautions:**

- ▶ When setting up the product, make sure that the accessories are correctly adapted, fitted, secured, and locked in position.
  - ▶ Avoid subjecting the product to mechanical stress.
- 

## **WARNING**

### **Distraction/loss of attention**

During dynamic applications, for example stakeout procedures, there is a danger of accidents occurring if the user does not pay attention to the environmental conditions around, for example obstacles, excavations or traffic.

#### **Precautions:**

- ▶ The person responsible for the product must make all users fully aware of the existing dangers.
- 

## **CAUTION**

### **Dropping the product**

When being dropped, the product can cause personal injury and/or mechanical damage.

#### **Precautions:**

- ▶ Secure the product when operating it.
-

## **WARNING**

### **Improper disposal**

If the product is improperly disposed of, the following can happen:

- If polymer parts are burnt, poisonous gases are produced which may impair health.
- If batteries are damaged or are heated strongly, they can explode and cause poisoning, burning, corrosion or environmental contamination.
- By disposing of the product irresponsibly you may enable unauthorised persons to use it in contravention of the regulations, exposing themselves and third parties to the risk of severe injury and rendering the environment liable to contamination.

#### **Precautions:**

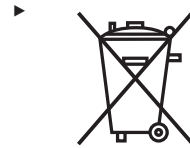

The product must not be disposed with household waste. Dispose of the product appropriately in accordance with the national regulations in force in your country. Always prevent access to the product by unauthorised personnel.

Product-specific treatment and waste management information can be received from your Leica Geosystems distributor.

## **NOTICE**

### **Improper shut down of the system**

This could lead to a loss of essential system information.

#### **Precautions:**

- ▶ Always ensure proper shut down of the system. Do not force shut down of the system.
- ▶ Release the power switch as soon as the shut-down splash screen appears.
- ▶ Usage of external battery or uninterruptible power supply (UPS) is recommended in an environment with frequent power outages or instable power grid.

## **WARNING**

### **Improperly repaired equipment**

Risk of injuries to users and equipment destruction due to lack of repair knowledge.

#### **Precautions:**

- ▶ Only authorised Leica Geosystems Service Centres are entitled to repair these products.

### For the AC/DC power supply and the battery charger:

#### **WARNING**

#### **Electric shock due to use under wet and severe conditions**

If unit becomes wet, it may cause you to receive an electric shock.

#### **Precautions:**

- ▶ If the product becomes humid, it must not be used!
- ▶ Use the product only in dry environments, for example in buildings or vehicles.



- ▶ Protect the product against humidity.
- 

### For the AC/DC power supply and the battery charger:

#### **WARNING**

#### **Unauthorised opening of the product**

Either of the following actions may cause you to receive an electric shock:

- Touching live components
- Using the product after incorrect attempts were made to carry out repairs.

#### **Precautions:**

- ▶ Do not open the product!
  - ▶ Only authorised Leica Geosystems Service Centres are entitled to repair these products.
- 

#### **WARNING**

#### **Exposure of batteries to high mechanical stress, high ambient temperatures or immersion into fluids**

This can cause leakage, fire or explosion of the batteries.

#### **Precautions:**

- ▶ Protect the batteries from mechanical influences and high ambient temperatures.
  - ▶ Consider the product's IP class restrictions in chapter [12 Technical Data](#).
  - ▶ Do not drop or immerse the product into fluids.
-

 **WARNING**

**Inappropriate mechanical influences to batteries**

During the transport, shipping or disposal of batteries it is possible for inappropriate mechanical influences to constitute a fire hazard.

**Precautions:**

- ▶ Before shipping the product or disposing it, discharge the batteries by the product until they are flat.
- ▶ When transporting or shipping batteries, the person in charge of the product must ensure that the applicable national and international rules and regulations are observed.
- ▶ Before transportation or shipping, contact your local passenger or freight transport company.

 **WARNING**

**Short circuit of battery terminals**

If battery terminals are short circuited e.g. by coming in contact with jewellery, keys, metallised paper or other metals, the battery can overheat and cause injury or fire, for example by storing or transporting in pockets.

**Precautions:**

- ▶ Make sure that the battery terminals do not come into contact with metallic/conductive objects.

 **WARNING**

**Short circuit of battery terminals**

Risk of fire, electric shock and damage.

**Precautions:**

- ▶ Do not open the battery housing.
- ▶ Keep away any metallic or wet objects from the battery terminals.

 **WARNING**

**Battery pack of the signal transmitter may get hot after prolonged use**

Risk of burning injuries.

**Precautions:**

- ▶ Avoid touching the hot battery pack.
- ▶ Allow the battery pack to cool down before removing it.

 **WARNING**

**Damaged battery**

If batteries are damaged or are heated strongly, they can explode and cause poisoning, burning, corrosion or environmental contamination.

**Precautions:**

- ▶ Protect the battery against mechanical damages.

## WARNING

### Damaged battery housing

There is a risk of fire. In case skin or eyes have come into direct contact with electrolytes leaking from the battery, rinse them thoroughly with clear water. Immediately contact a doctor.

#### Precautions:

- ▶ Stop using the battery.
- ▶ Turn off any charging in action.
- ▶ If any electrolytes should leak from a damaged battery, avoid skin contact and direct inhalation of gases.

## NOTICE

### Removal of battery during operation or shutdown

This can result in a file system error and data loss!



#### Precautions:

- ▶ Do **NOT** remove the battery during operation of the instrument, or during the shutdown procedure.
- ▶ Always switch off the instrument by pressing the On/Off key, and wait until the instrument has shutdown completely before removing the battery.

## 1.6

## Laser Classification

### 1.6.1

### General

#### General

The following chapters provide instructions and training information about laser safety according to international standard IEC 60825-1 (2014-05) and technical report IEC TR 60825-14:2022. The information enables the person responsible for the product and the person who actually uses the equipment, to anticipate and avoid operational hazards.



According to IEC TR 60825-14:2022, products classified as laser class 1, class 2 and class 3R do not require:

- laser safety officer involvement
- protective clothes and eyewear
- special warning signs in the laser working area

if used and operated as defined in this User Manual due to the low eye hazard level.



National laws and local regulations could impose more stringent instructions for the safe use of lasers than IEC 60825-1 (2014-05) and IEC TR 60825-14:2022.

## 1.6.2

## Rugby CLAx

### General

The rotating laser built into the product produces a visible laser beam which emerges from the rotating head.

The laser product described in this section is classified as laser class 2 in accordance with:

- IEC 60825-1 (2014-05): "Safety of laser products"

These products are safe for momentary exposures but can be hazardous for deliberate staring into the beam. The beam may cause dazzle, flash-blindness and after-images, particularly under low ambient light conditions.

Description	Value
Maximum peak radiant power	0.8 mW / 2.8 mW
Pulse duration (effective)	Rotating: 500 ms / 5.6 ms, 2.9 ms, 1.4 ms, 1.0 ms, 0.7 ms Scanning: 34 ms, 36 ms, 40 ms
Pulse repetition frequency	0 Hz, 2 Hz, 5 Hz, 10 Hz, 15 Hz, 20 Hz
Beam divergence	0.2 mrad
Wavelength	635 nm

### CAUTION

#### Class 2 laser product

From a safety perspective, class 2 laser products are not inherently safe for the eyes.

#### Precautions:

- ▶ Avoid staring into the beam or viewing it through optical instruments.
- ▶ Avoid pointing the beam at other people or at animals.

### Labelling Rugby CLAx

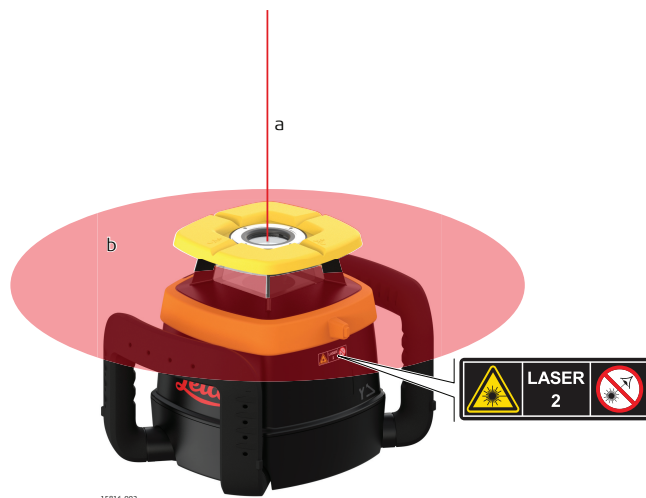

- a Laser beam, Plumb beam
- b Rotating laser beam

**Description**

The term Electromagnetic Compatibility is taken to mean the capability of the product to function smoothly in an environment where electromagnetic radiation and electrostatic discharges are present, and without causing electromagnetic disturbances to other equipment.

---

** CAUTION****Electromagnetic radiation**

Electromagnetic radiation can cause disturbances in other equipment.

**Precautions:**

- ▶ Although the product meets the strict regulations and standards which are in force in this respect, Leica Geosystems cannot completely exclude the possibility that other equipment may be disturbed.
- 

** CAUTION****Use of the product with accessories from other manufacturers. For example, field computers, personal computers or other electronic equipment, non-standard cables or external batteries**

This may cause disturbances in other equipment.

**Precautions:**

- ▶ Use only the equipment and accessories recommended by Leica Geosystems.
  - ▶ When combined with the product, other accessories must meet the strict requirements stipulated by the guidelines and standards.
  - ▶ When using computers, two-way radios or other electronic equipment, pay attention to the information about electromagnetic compatibility provided by the manufacturer.
- 

** CAUTION****Intense electromagnetic radiation. For example, near radio transmitters, transponders, two-way radios or diesel generators**

Although the product meets the strict regulations and standards which are in force in this respect, Leica Geosystems cannot completely exclude the possibility that the function of the product may be disturbed in such an electromagnetic environment.

**Precautions:**

- ▶ Check the plausibility of results obtained under these conditions.
-

## CAUTION

### **Electromagnetic radiation due to improper connection of cables**

If the product is operated with connecting cables, attached at only one of their two ends, the permitted level of electromagnetic radiation may be exceeded and the correct functioning of other products may be impaired. For example, external supply cables or interface cables.

#### **Precautions:**

- ▶ While the product is in use, connecting cables, for example product to external battery or product to computer, must be connected at both ends.
- 

## WARNING

### **Use of product with radio or digital cellular phone devices**

Electromagnetic fields can cause disturbances in other equipment, installations, medical devices, for example pacemakers or hearing aids, and aircrafts. Electromagnetic fields can also affect humans and animals.

#### **Precautions:**

- ▶ Although the product meets the strict regulations and standards which are in force in this respect, Leica Geosystems cannot completely exclude the possibility that other equipment can be disturbed or that humans or animals can be affected.
  - ▶ Do not operate the product with radio or digital cellular phone devices in the vicinity of filling stations or chemical installations, or in other areas where an explosion hazard exists.
  - ▶ Do not operate the product with radio or digital cellular phone devices near medical equipment.
  - ▶ Do not operate the product with radio or digital cellular phone devices in aircrafts.
  - ▶ Do not operate the product with radio or digital cellular phone devices for long periods with the product immediately next to your body.
-

## 2

## Description of the System

---

### 2.1

### System Components

---

#### General description

The Rugby lasers are tools for general construction, levelling and slope applications such as:

- Setting forms
- Levelling to grade
- Controlling depths for excavations

If set up within the self-levelling range, the Rugby automatically levels to create an accurate horizontal, vertical or sloped plane of laser light. Once the Rugby has levelled, the head starts rotating and the Rugby is ready for use. 30 seconds after the Rugby has completed the self-levelling, the H.I.Alert system becomes active and protects the Rugby against changes in elevation caused by movement of the tripod to ensure accurate work.

#### Area of application

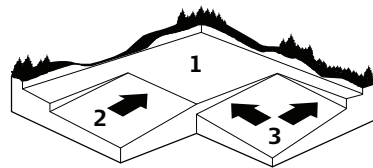

The Rugby, depending on the configuration, is a dual grade laser. The laser produces an accurate plane of laser light for applications which require level (1), single slope (2) or dual slope (3).

---

Available system components



29173\_001



The delivered components depend on the package ordered.

2.2

**Product Variants**

**Available Product Variants**

A wide range of product variants are available for use on the Rugby hardware depending on the installed package with various features.

Laser Model	Variant
CLAx	<ul style="list-style-type: none"> <li>• CLAx250</li> <li>• CLAx550</li> <li>• CLAx700</li> </ul>

**Basic Features**

The following basic features are included:

Feature	Functionality
Horizontal	✓
Self-levelling ±6°	✓
Accuracy ±10"	✓
Calibration	✓
Manual mode	✓

Feature	Functionality
H.I.Alert	✓
Temperature alert 50 °C	✓
Battery alert	✓
Head stall alert	✓
Head speed 10	✓
Operating range (diameter) communication Combo+ 600 m	✓
Operating range (diameter) receiver Combo+ 1300 m	✓
50 h operating time on one charge	✓
Head speed 7, battery	✓

## Features Rugby CLAx

Depending on the version of the CLAx, the following features are usable:

Feature	CLAx250	CLX550	CLAx700 <sup>1)</sup>
Manual slope DG ±8%	✓	✓	✓
Slope Catch and Slope Lock	✓	✓	✓
Beam masking	✓	✓	✓
Temperature stability control 2 °C, 5 °C, Off	✓	✓	✓
Semi-automatic calibration	✓	✓	✓
Head speed 15	-	✓	✓
Sideways oper- ation	-	✓	✓
Scan Catch	-	✓	✓
Scanning 10°, 45°, 90°	-	✓	✓
Head speed 0, 2, 5	-	✓	✓
Grade dial-in ±15%	-	-	✓
Auto grade	-	-	✓
Single grade	-	-	✓
Axis alignment	-	-	✓
Dual grade ±15%	-	-	✓
Plumb up beam	-	-	✓

<sup>1)</sup> Digital grade displayed

## 2.3

## Rugby Laser Components

### Rugby laser components



- a Vertical plumb window
- b Plate for optional scope
- c Carry handle
- d Screen
- e Keypad
- f Product variant label
- g Battery compartment

## 2.4

## Case Components

### Case components

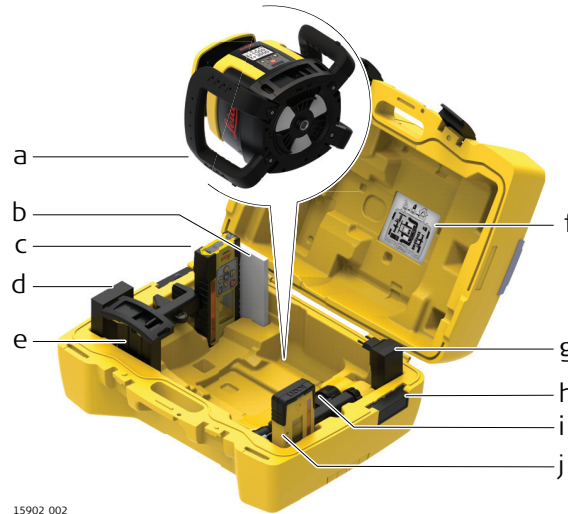

15902.002

- a Rugby laser
- b User Manual, CD, Safety instructions, Quick Guide, Protect card
- c Combo+ with bracket
- d Power bank and cable\*
- e Second battery\*
- f Case label
- g Charger
- h Flexible name tag\*
- i Scope assembly\*
- j Rod Eye with bracket\*

\*Optional

## 2.5

## Setup

### Location

- Keep the location clear of possible obstructions that could block or reflect the laser beam.
- Place the Rugby on stable ground. Ground vibration and extremely windy conditions can affect the operation of the Rugby.
- When working in a very dusty environment place the Rugby up-wind so the dirt is blown away from the laser.

## Setting up on a tripod



15849.002

1. Set up the tripod.
  2. Place the Rugby on the tripod.
  3. Tighten the screw on the underside of the tripod to secure the Rugby on the tripod.
- Always check the tripod before attaching the Rugby. Make sure all screws, bolts and nuts are tight.
  - If a tripod has chains, they should be slightly loose to allow for thermal expansion during the day.
  - Secure the tripod on extremely windy days.

## 3 Operation

### 3.1 Control Panel

#### Overview

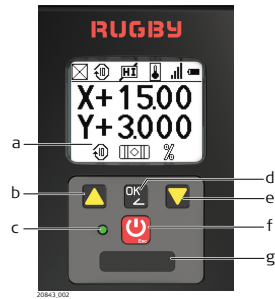

- a LCD display
- b Arrow up button
- c Status LED
- d OK/Grade button
- e Arrow down button
- f Power button
- g Product variant label

#### Functions

Component	Description
LCD display	Displays all required user information.
Power button	Press to turn the Rugby on or off.
Status LED	Indicates the level status of the Rugby.
OK/Grade button	Press to confirm selections.
Arrow up/down button	Press to select and change values.

### 3.2 Turning the Rugby On and Off

#### Turn on and off

Press the Power button to turn the Rugby on or off.

#### After turning on:

- The LCD display turns on and displays the current status of the Rugby.
- If set up within the  $\pm 6^\circ$  self-levelling range (horizontal or vertical), the Rugby automatically levels to create an accurate horizontal plane of laser light.
- Once levelled, the head starts rotating and the Rugby is ready for use.
- The H.I.Alert system becomes active 30 seconds after completing the self-levelling. The H.I.Alert system protects the Rugby against changes in elevation caused by any movement or settling of the tripod.
- The self-levelling system and the H.I.Alert function continue to monitor the position of the laser beam to ensure consistent and accurate work.



The H.I.Alert function turns on automatically every time the Rugby is turned on.

### 3.3 The LCD Display

#### Main display

The LCD display shows all the information that is required to operate the Rugby. For a more comprehensive display, a Combo+ is necessary.

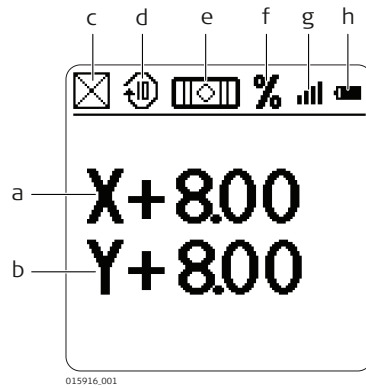

- a X-axis grade value
- b Y-axis grade value
- c Beam masking
- d Head speed
- e Manual/self-levelling
- f Percent
- g Paired status
- h Battery level indication



When the H.I.Alert or Temperature check is disabled, a small icon is shown on the Combo+ and Rugby.

## Start-up Screens

When you turn on the Rugby, the LCD displays the Leica welcome screen, the customer name screen and the information screen.

### Leica welcome screen



### Leica Customer name screen



The screen only appears if you enabled it in the menu. Refer to [4.3.3 Menu Set 2-Customer name](#).



### Leica Information screen

The information screen displays the model version, firmware version and hardware number.

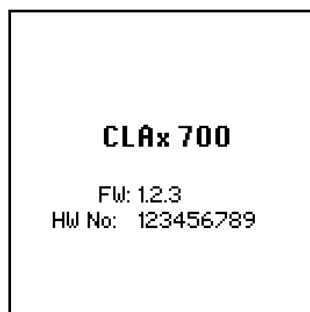

Rugby CLAx

## 3.4

### Axis Identification

#### Axis identification

When entering grade, it is important to know the correct direction in which the grade is being entered.

Refer to the following illustration to identify the correct directions of the axes.

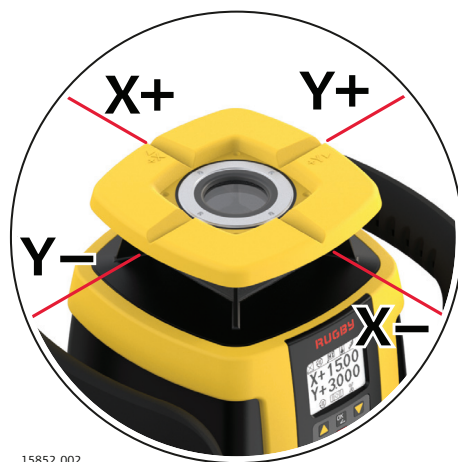

## 3.5

### Conversion of Slope Into Percent of Grade

#### Conversion of slope

Slope: The change in elevation per unit of measure (foot, metre, etc.)

Percent of Grade: The change in elevation per 100 units of measure (feet, metre, etc.)

#### Calculating percent of grade from slope:

$$[\text{Slope}] \times 100 = [\text{Percent of Grade}]$$

Example:

Slope	= 0.0059
Conversion	= 0.0059 x 100
Percent of Grade	= 0.590%

## 3.6

### Alignment of the Axes

#### Aligning X- and Y-axis

1. Align the X-axis and Y-axis.

2. Set the desired grade in the display.



Ensure that you first align the axes and then set the grade, otherwise the Rugby may trigger the HI.Alert.



Ensure that the Rugby is properly positioned over a control point.

The direction of the X-axis is seen from the front of the Rugby, sighting over the top of the Rugby.



15856\_002

3. Rotate the Rugby slightly until the alignment marks are aligned with your second control point.



The Rugby CLAx sighting scope can be used to help with the alignment.

4. Once the Rugby is aligned, you can start working.

### 3.7

#### Precisely aligning X- and Y-axis

#### Precise Alignment of the Axes

Under most conditions, the raised alignment marks on the top of the Rugby are adequate for alignment of the axes. For a more precise alignment, you can use the following procedure.

Objective of a precise alignment:

- To establish Point A on the Y-axis as a reference and take an elevation reading.
- To enter grade into the X-axis and then adjust the position of the laser until the original elevation at Point A is again found.

1. With 0.000% grade in both axes, set up the Rugby directly over a grade stake and roughly align the Y-axis to a second grade stake (Point A).
2. Take an elevation reading at Point A using a Combo+ and a survey rod.

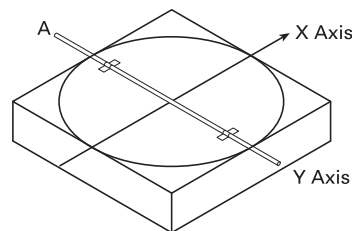

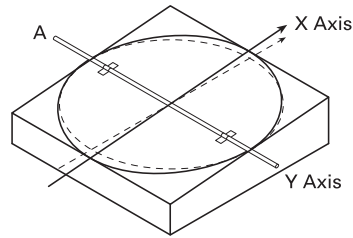

3. Enter +5.000% grade into the X-axis. When grade is entered into the X-axis, the Y-axis acts like a hinge or fulcrum.

- With +5.000% in the X-axis, take a second reading at Point A.



- Alignment:
  - If the second reading is equal to the first reading, the X-axis is aligned correctly.
  - If the second reading is greater than the first reading, rotate the Rugby clockwise (to the right) until the two readings are equal.
  - If the second reading is less than the first reading, rotate the Rugby counter-clockwise (to the left) until the two readings are equal.

 Sighting Scope - An optional sighting scope is available for the Rugby CLAx which improves the axis alignment for second day setups. It is recommended that you first perform the precise alignment procedure, and then adjust the scope to these axes.

 Automatic Axis Alignment - Automatic axis alignment is possible in the X-axis with the Rugby CLAx using the Combo+. (Refer to [6.11 Automatic Axis Alignment](#))

## 3.8

### Grade Entry

#### 3.8.1

#### Grade Entry with Combo+

##### Direct grade entry

- Rugby CLAx:**  
On the Combo+ press the OK/Grade button once to start the grade entry mode.  
The X-axis grade value will be highlighted.



Press the Down/Sleep button to select the Y-axis grade value.

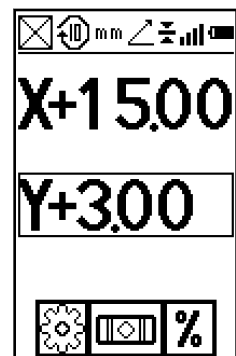
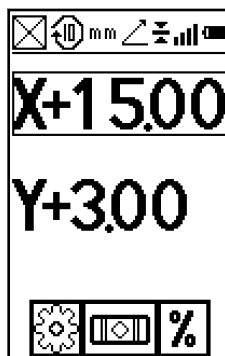

- Select the grade value.
- Press the Up/Menu button or Down/Sleep button to change the grade value.

4. Press the OK/Grade button to confirm the selection.
5. Press the Power/ESC button for a short time to exit the grade entry mode. The Main screen appears.

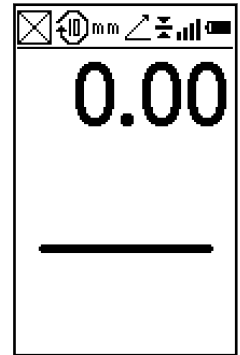

## Grade entry by digit



On the Combo+ press the OK/Grade button once to start the grade entry mode.



1. Select the axis and press the Left/Bandwidth button or Right/Volume button to create a cursor. The cursor always appears on the plus/minus sign.

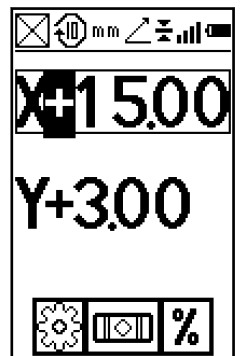

2. Select the grade value.
3. Press the Up/Menu button or Down/Sleep button to change the grade value. Press the Left/Bandwidth button or Right/Volume button to change a digit.

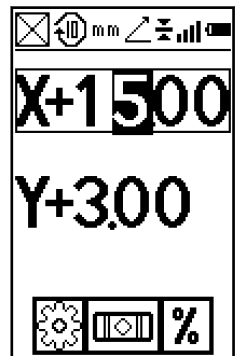

4. Press the OK/Grade button to confirm the selection.

- Press the Power/ESC button for a short time to exit the grade entry mode. The Main screen appears.

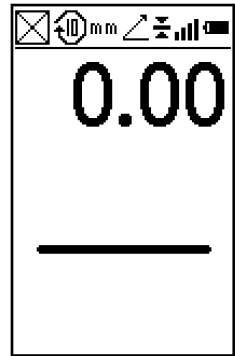

### 3.8.2

### Grade Entry with Rugby CLAx

#### Direct grade entry

- Press the OK/Grade button once to start the grade entry mode. The X-axis grade value will be highlighted.



20823.001

Press the Down arrow button to select the Y-axis grade value.

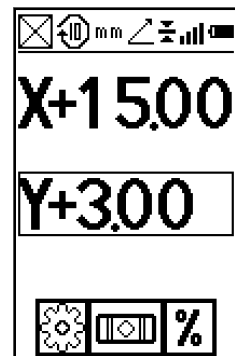
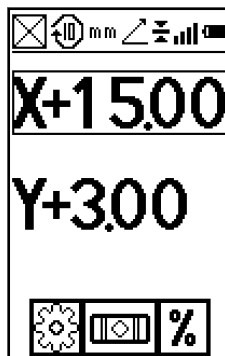

- Select the grade value.
- Press the Up arrow button or Down arrow button to change the grade value.
- Press the OK/Grade button to confirm the selection or wait 10 seconds for auto confirmation.
- Press the Power/ESC button for a short time to exit the grade entry mode. The Main screen appears.

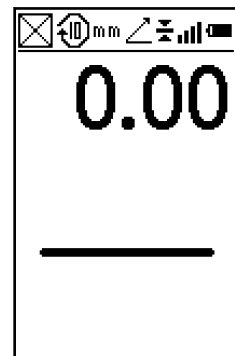

### Reset grade value to zero

While in grade entry mode, you can quickly change the grade value back to zero by pressing the Up/Menu button and Down/Sleep button simultaneously.

### Grade capability

Laser	Grade capability simultaneously in both axes	Grade capability in one axis
Rugby CLAx	up to 10%	up to 15%

#### Example:

The Rugby CLAx can have up to 10.00% grade simultaneously in both the X and Y axes or up to 15.00% grade in one axis.

Entering grades above 10.00% in one axis is only possible if the cross axis grade is  $\pm 3\%$  or lower.

### Grade swap

The grade in the X and Y axes can be swapped from positive to negative by changing the plus/minus sign in grade entry mode. Refer to [3.8 Grade Entry-Grade entry by digit](#).

A typical application for this feature is road building.

Example: The Rugby is set up on the crown of the road and one axis is aligned to the centreline. In order to make the cross axis grade fall to the right or left hand side, simply change the plus/minus sign on the Combo+ grade screen.

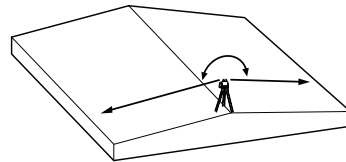

## 3.9

### Vertical Operation

#### Vertical plane of laser light

You can operate the Rugby CLAx lying on its side in order to create a vertical plane of laser light for layout and alignment jobs.



Rugby lying on its side

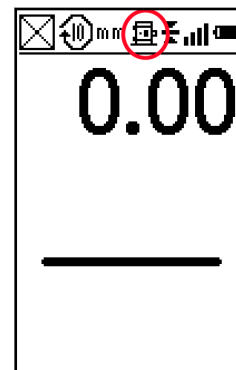

Combo+ screen when operating the Rugby on its side.



When operating the Rugby CLAx lying on its side, only the Z-axis is levelled. Alternatively, manual grade operation is also possible.

# 4

## Combo+

### 4.1

### Description of the Combo+

#### Description

The Combo+ communicates with the Rugby through RF (Radio Frequency) and is used to control the functions of the Rugby.

The Combo+ has a built-in backlight that is activated by a touch of any button or the detection of a red laser beam.

 The backlight is active for approximately 15 seconds.

#### Instrument components part 1 of 2



0015860.001

- a Audio speaker
- b Screen
- c Laser reception window
- d Centre marking
- e Keypad

Component	Description
Audio speaker	Indicates the position of the Combo+: <ul style="list-style-type: none"> <li>• High - Fast beeping</li> <li>• On-grade - Solid tone</li> <li>• Low - Slow beeping</li> </ul>
Screen	Front and rear LCD arrow indicate the position of the Rugby laser beam.
Laser reception window	Detects the laser beam. The reception window must be directed towards the laser. Front and rear LCD indicate the position of the Combo+ in relation to the beam, using arrows and the Digital Read Out values.
Centre marking	Indicates the on-grade position of the Rugby laser beam.
Keypad	Power, accuracy, volume, sleep and menu functions.

#### Instrument components part 2 of 2



0015861.001

- a Bracket mounting hole
- b Centre notch
- c Product label
- d Battery door

Component	Description
Bracket mounting Hole	Location to attach the Combo+ bracket for normal operation.

Component	Description
Centre notch	Use to transfer reference marks. The notch is 85 mm (3.35") below to top of the detector.
Product label	The serial number is located on the product label.
Battery door	Battery compartment can only be opened by an authorised Leica service partner.

## Keypad

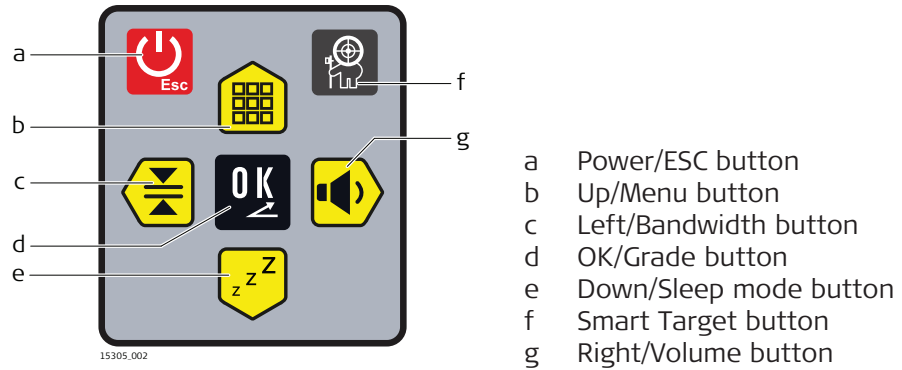

- a Power/ESC button
- b Up/Menu button
- c Left/Bandwidth button
- d OK/Grade button
- e Down/Sleep mode button
- f Smart Target button
- g Right/Volume button

## Description of the buttons

Button	Description
Power/ESC button	Long press to turn the Combo+ on or off. Short press to leave a screen and return to the main screen.
Up/Menu button	When on main screen, press to enter the menu. Press to navigate up in the menu.
Left/Bandwidth button	When on main screen, press to toggle the bandwidth. Press to navigate left in the menu.
OK/Grade button	Press to select or confirm an option. When on main screen, press to start grade entry mode.
Down/Sleep button	When on main screen, press to enter sleep mode. Press to navigate down in the menu. <ul style="list-style-type: none"> <li>• During sleep mode, all functions are disabled.</li> <li>• The LCD screen indicates that the Rugby is in sleep mode.</li> <li>• The Rugby sleeps for 2 hours, then shuts down automatically and must be turned on again at the laser.</li> <li>• When in sleep mode, pressing any button wakes the Rugby and normal operation is resumed.</li> </ul>
Smart Target button	Provides access to various special functions. <ul style="list-style-type: none"> <li>• Slope Catch: Allows you to match an existing grade.</li> <li>• Slope Lock: Monitors the grade position to keep the Rugby on grade.</li> <li>• Axis Alignment: Electronically adjusts the axes of the Rugby.</li> <li>• Scan Catch: Searches for the Combo+, and once found, produces a 10° scan in the direction of the Combo+.</li> </ul>

Button	Description
Right/Volume button	Press to toggle the volume. Press to navigate right in the menu.
	 Press both left and right simultaneously to lock and unlock the keypad and prevent accidental button presses when on the main screen.

## 4.2

### Connecting Screens for the Combo+

#### Information screens while connecting

There are three screens on the Combo+ which are displayed when connecting to the Rugby.

#### Searching animation

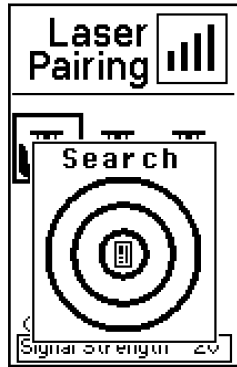

#### Pairing unsuccessful

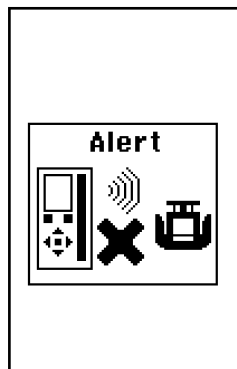

Ensure that you are within clear sight of the Rugby and that you have not exceeded the working range.

## 4.3

### Combo+ Menu

#### 4.3.1

#### Access and Navigation

#### Description

The Combo+ has several menu options that allow you to optimise the performance of the Rugby for an individual application.

To access the menu of the Combo+, press the Up/Menu button while the main screen is displayed.



The quantity and placement of options shown may not be representative of your product. Features shown depend on the laser model variant in operation. Refer to [2.2 Product Variants](#).

## Navigation within the Menu:



Keypad of the Combo+

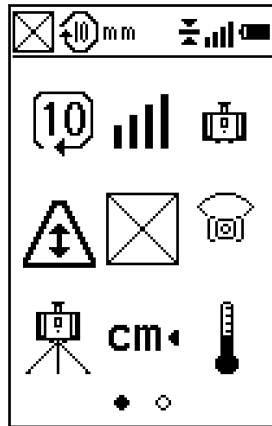

Once in the menu, use the yellow buttons to navigate.

Press the Up, Down, Left and Right buttons to move the cursor and highlight an icon or an option.

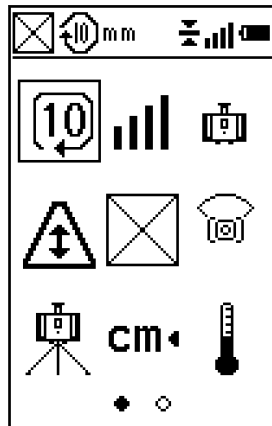

A highlighted icon is surrounded by a box. To navigate to the second menu page, press the Right/Volume button until page two is displayed.

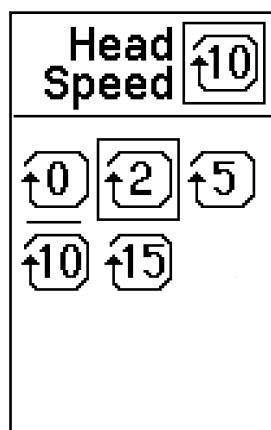

The currently active option is underlined. Press the OK/Grade button to select an icon.

### Navigation within the menu without connected or powered on Rugby:

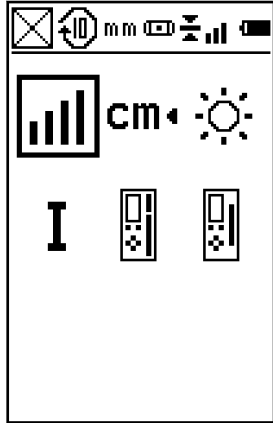

If there is no Rugby paired with the Combo+ a reduced menu screen is shown. This menu is limited to features that do not require an active connection to a Rugby.

### Crossed-out icons

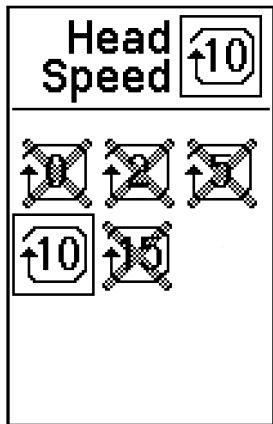

The quantity and placement of options shown may not be representative of your product. Features shown depend on the laser model variant in operation. Refer to [2.2 Product Variants](#).

Overview

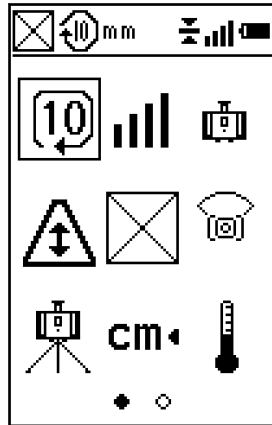

Menu Set 1

In the Menu Set 1, you can select the following options, depending on the laser model variant in operation:

- Head speed
- Pairing
- Beam down mode
- H.I.Alert
- Beam masking
- Scanning mode
  - Scanning width
  - Scanning direction
  - Scanning axis
- Sensitivity
- Unit
- Temperature sensitivity



To exit the menu, press the Power/ESC button for a short time.



Press the Right/Volume button until page two is displayed to display the Menu Set 2.

Head speed

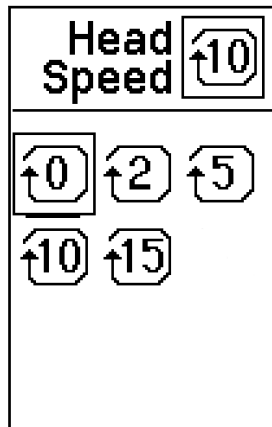

You can select up to six head speed settings, depending on the laser model variant in operation:

- 0 rps
- 2 rps
- 5 rps
- 10 rps
- 15 rps



7 rps is automatically set when in low-power mode.

Pairing

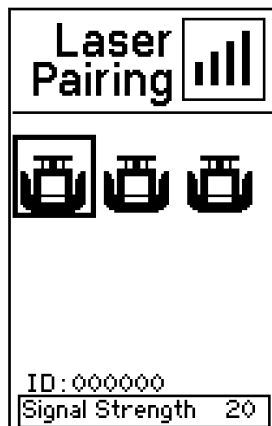

The Rugby and the Combo+ include radio modules that allow remote control up to 300 m (1000') away.



With a new Rugby and Combo+ package, the Rugby and the Combo+ come pre-paired.

If a Combo+ has to be paired with a Rugby laser, do the following:

1. Turn on the Rugby and the Combo+.
2. Enter the menu screen on the Combo+.
3. Select the pairing search menu.  
*The searching process begins.*



When the search is successful:  
A laser icon appears. The Rugby displays a flashing screen and gives an audio feedback.



When the search is **not** successful:  
Either no Rugby lasers are found or the desired Rugby is not available.

4. Press the OK/Grade button to pair the Rugby.

## Beam down mode



For layout work, use the beam down mode to position the beam over a reference point. Then use the scan mode to move the small scan quickly to a position to the left or right of the Rugby.  
Alternatively, press beam down to stop the rotating head (0 rps). Refer to [4.3.2 Menu Set 1-Head speed](#).

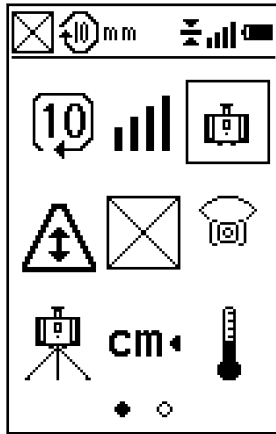

When the Rugby is operated lying on its side the beam down mode is activated automatically.

## Beam masking

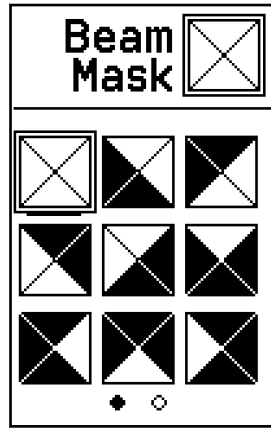

Beam masking screen

Beam masking allows you to turn off the laser beam on selected sides of the Rugby. It prevents interference with other lasers or receivers that could be working in the same working area.



Additionally, beam masking is useful when you work in a sensitive environment, close to public eyeline or near reflective surfaces.

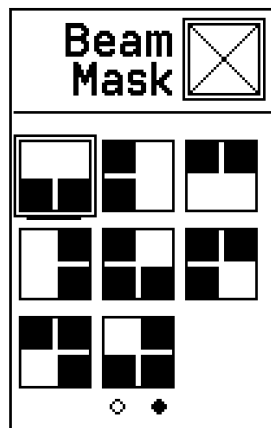

Possible combinations

You can choose to block two quarters or three quarters of the rotating laser beam. Each of the four displayed combinations is available in four different variants. The dark area represents the area where the laser beam is turned off. Use the Up/Menu button and Down/Sleep button or Left/Bandwidth button and Right/Volume button to choose from the 16 possible combinations over 2 pages.

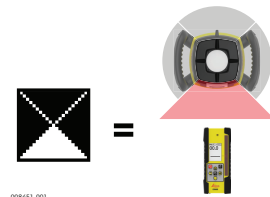

Example

## Scanning mode

The default Rugby scan setting is a 360° range of movement. It is possible, though, to restrict the beam to certain predefined ranges. Go to the Scanning mode screen to alter the beam range in terms of width, direction and axis.

### Scanning width



There are three scanning widths available:

- 10°
- 45°
- 90°

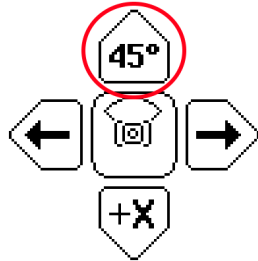

Press the Up/Menu button repeatedly to change the scanning widths.

### Scanning direction

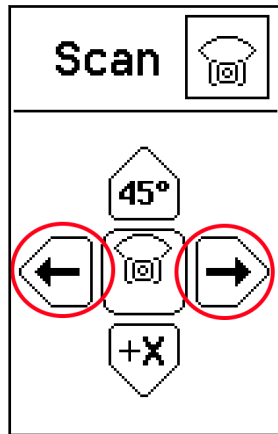

The default direction of the scan is directly in the +X axis. Within the Scanning direction submenu, it is possible to control the direction of the scan manually.

Press the Left/Bandwidth button or Right/Volume button to control the direction.

### Scanning axis

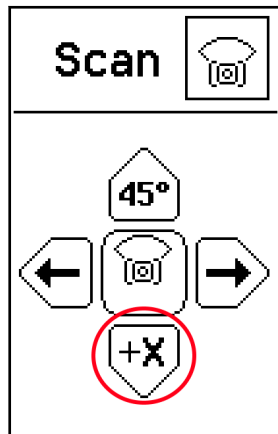

The default direction of the scan is directly in the +X axis. Within the Scanning axis submenu, it is possible to redirect the scan to another axis.

Press the Down/Sleep button to toggle between the four axes.

### Returning to 360° range

In the Scanning mode screen press the OK/Grade button to return the Rugby to full 360° range.

## H.I.Alert - On/Off

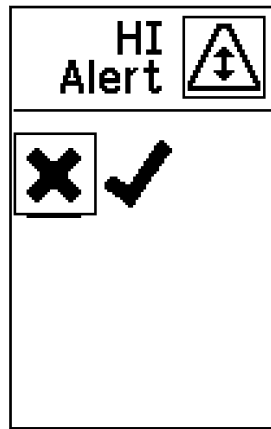

H.I.Alert select

You can choose to enable or disable the H.I.Alert function:

- On
- Off

When enabled, the H.I.Alert function turns on automatically every time the Rugby is turned on. The function becomes active 30 seconds after turning on the Rugby.

When this feature is disabled, a small icon appears momentarily on the Rugby, in place of the last digit.



When the H.I.Alert is disabled, a small icon is shown on the Combo+ and Rugby.

### How does the H.I.Alert function work

The Height of Instrument (H.I.) or Elevation Alert function prevents incorrect work caused by movement or settling of the tripod that would cause the laser to self-level at a lower height.

30 seconds after the Rugby has levelled and the head of the laser starts rotating, the H.I.Alert function becomes active.

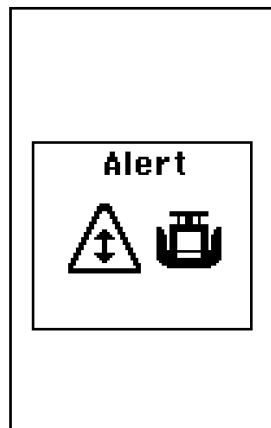

H.I.Alert activated

The H.I.Alert function monitors the movement of the laser; if disturbed, the H.I.Alert screen flashes and the Rugby beeps rapidly.

To stop the alert, turn the Rugby off and on again. Check the height of the laser before beginning to work again.

Refer to [10 Troubleshooting-Alerts and message screens](#).



The H.I.Alert function turns on automatically every time the Rugby is turned on.

## Sensitivity

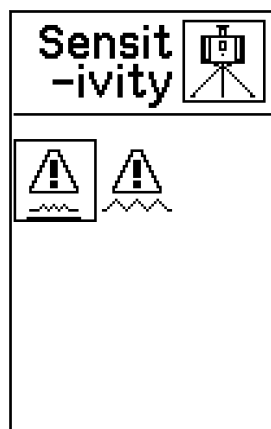

While in use, the Rugby responds to disturbances, for example wind or vibrations, and stops the head rotation, if necessary. You can choose between two levels of sensitivity:

- Sensitivity Setting 1: For normal performance - wind, vibration and other disturbances are minimal.
- Sensitivity Setting 2: For situations when wind, vibration and other disturbances are more severe.

## Unit select

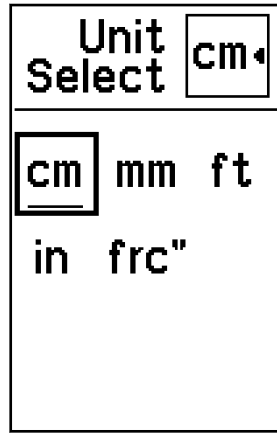

While a beam is being detected on the main screen, the digital read out displays the distance the beam is to the centre point on the Combo+. Within the Unit settings menu, it is possible to select the units of the distance measurement:

- cm
- mm
- Inches
- Feet
- Fractional inches

## Temperature sensitivity

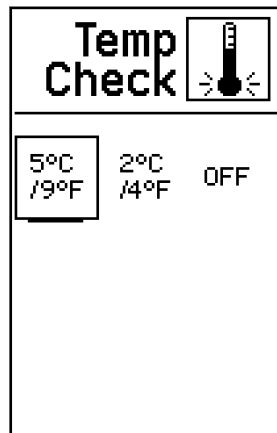

For each change in temperature of  $\pm 5\text{ }^{\circ}\text{C}$  ( $\pm 9\text{ }^{\circ}\text{F}$ ) the Rugby returns to the level position to check if the change in temperature has led to a change of the main levelling system. For a more sensitive unit, you can change the setting to  $\pm 2\text{ }^{\circ}\text{C}$  ( $\pm 4\text{ }^{\circ}\text{F}$ ) temperature change.

Alternatively, you can completely disable this feature. As a result, changes in temperature are not monitored for the purposes of the internal levelling system functionality.

☞ Disabling the feature turns off the controlling mechanism.

☞ When the Temperature sensitivity check is disabled, a small icon is shown on the Combo+ and Rugby.

Available intervals:

- Temperature is checked every  $5\text{ }^{\circ}\text{C}/9\text{ }^{\circ}\text{F}$
- Temperature is checked every  $2\text{ }^{\circ}\text{C}/4\text{ }^{\circ}\text{F}$
- Off

## Temperature check wait screen

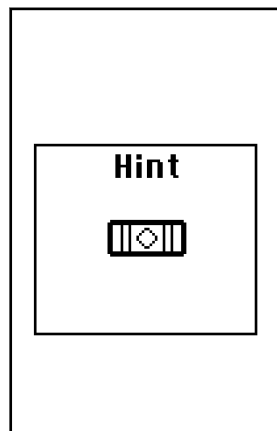

When the Rugby is re-levelling, the Temperature check wait screen is displayed. Wait until the process is finished before using the Rugby again. The Status LED flashes on the Rugby to indicate normal levelling.

## Overview

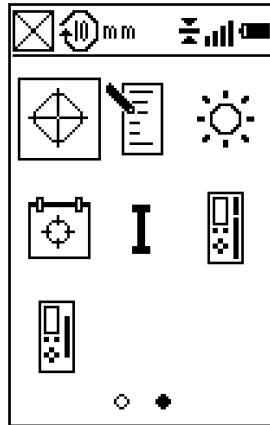

Menu Set 2

In the Menu Set 2, you can select the following parameters, depending on the laser model variant in operation:

- Calibration
- Customer name
- Screen contrast
- Calibration alert function
- System info
- Centre line offset
- Combo+ window size



To exit the menu, press the Power/ESC button for a short time.

## Calibration

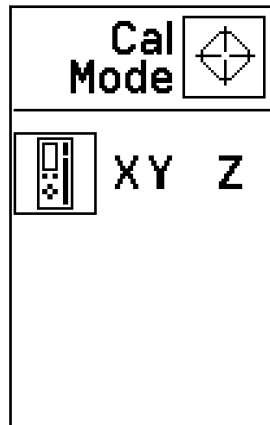

In the calibration menu, you can select the following options:

- Semi-auto calibration. Refer to [9 Semi-Automatic Calibration](#).
- Manual calibration of X & Y. Refer to [8.2 Adjusting the Self-Levelling Accuracy](#).
- Manual calibration of Z. Refer to [8.3 Adjusting the Vertical Accuracy](#).

## Customer name

The Customer name setting allows you to enter user details and to enable/disable the Customer name screen as the start screen when the Rugby is turned on.

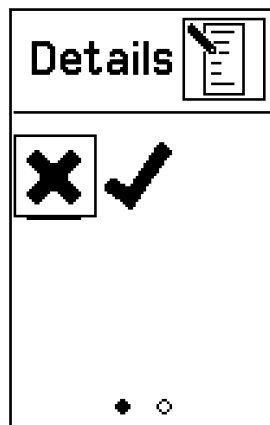

#### Enable/Disable the Customer name screen as start screen

Select between two options:

- Display (YES): The Customer name screen is displayed each time the Rugby is turned on.
- Save only (NO): The information entered in the Customer name screen is stored in the Rugby, but is only visible when the screen for entering the customer name is accessed.



You can enter 3 lines of text with up to 13 characters per line.

- Company
- Town
- Phone Number

### Screen contrast

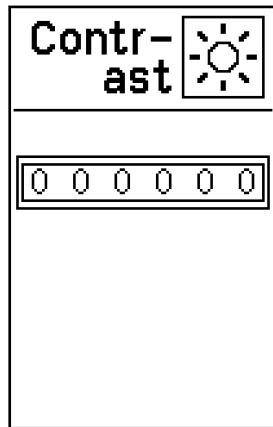

With this setting, you can change the screen contrast of the Combo+.

Use the Left/Bandwidth button and Right/Volume button to adjust the contrast.

### Calibration alert function

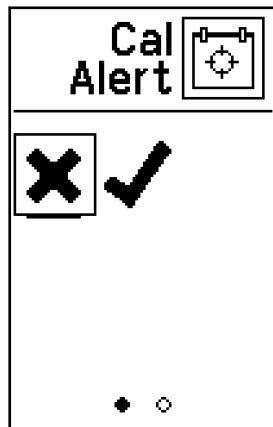

#### Enable/Disable the calibration alert function

The calibration alert function is based on hours of use.

- ON: Calibration alert is enabled.
- OFF: Calibration alert is disabled.

### Calibration alert screen on Start-up

If the calibration alert function is enabled, the screen for entering the alert time is displayed whenever the Combo+ connects with the Rugby.

### Calibration Alert Time on Start-up screen

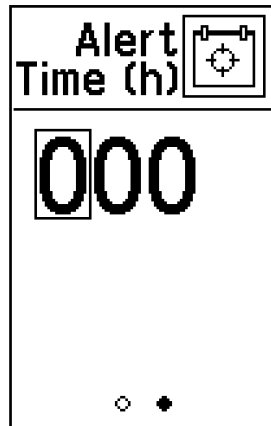

To be alerted that a calibration is necessary after a specified time of operation, enter the desired hours that shall pass before the alert appears.

### Calibration Alert flashing screen

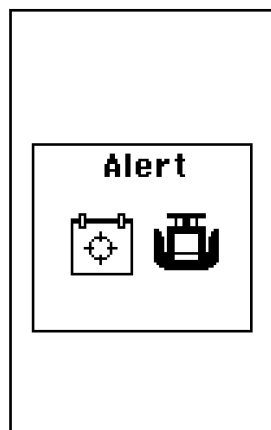

When the number of planned hours has passed, the calibration alert is displayed for 8 seconds. After calibrating the Rugby, the Calibration Alert Time is automatically reset. Changing or disabling the alibration alert is only possible by accessing the menu option "Calibration alert function".

### Centre line offset

The Centre line offset allows you to change the position of the centre line.

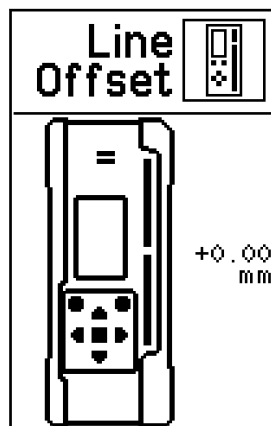

1. Move the Combo+ so the beam is on the desired centre line position.
2. Press the OK/Grade button to confirm the new centre line position.



Centre line offset is not compatible with Combo+ window size.



To reset the offset, press the OK/Grade button when no beam is detected on the window.

## Combo+ receiving window modification

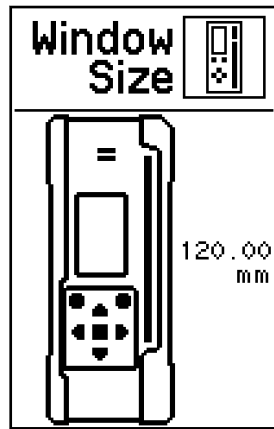

The default height of the Combo+ window is 120 mm/4.72 inches.

The height can be reduced by 50 mm/1.97 inches.

1. Press the Up/Menu button and Down/Sleep button to modify the window size.
2. Press the OK/Grade button to confirm the new window size.



Combo+ window modification is not compatible with Centre line offset.

## 4.3.4

### Grade Entry

#### Overview

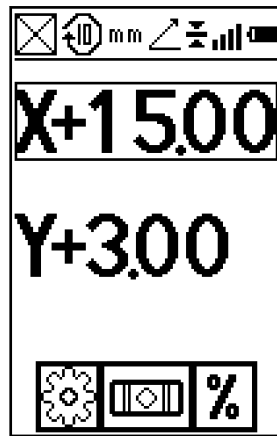

Grade entry screen

In the Grade entry screen, you can modify the grade values and select the laser model variant, depending on the model variant in operation:

- Automatic/Manual Mode
- Display - Percent/Per Mil
- Display - Thousandths/Hundredths
- Save Grade Enabled/Disabled
- Negative Grade Enabled/Disabled



To exit the menu, press the Power/ESC button for a short time.

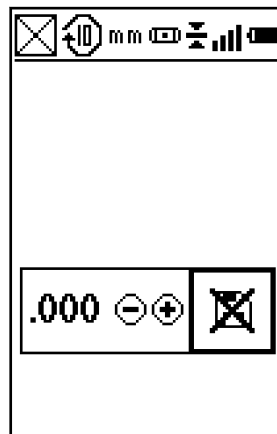

Grade entry options screen

## Automatic/manual mode

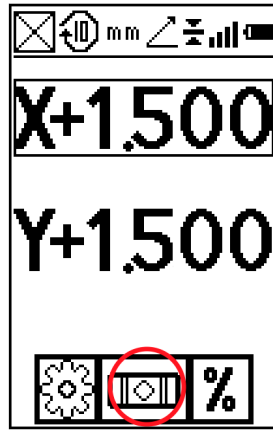

Automatic/manual mode settings

### Automatic mode

The Rugby always turns on in automatic mode and continuously self-levels to maintain grade accuracy.

### Manual mode

In manual mode the self-levelling function is turned off. The Manual mode screen is displayed instead of the normal main screen. The plane of the laser light can be manually sloped using the same buttons as for direct grade entry, but no value for the grade is shown in the display.

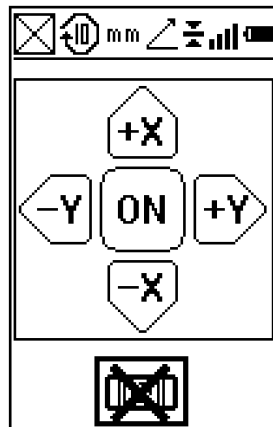

Manual mode screen

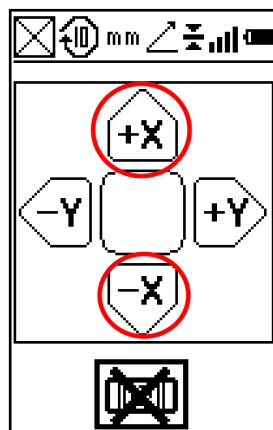

You can select from three different modes, depending on the laser model variant in operation:

- Automatic mode (default)
- Manual mode
- Semi-automatic mode



You can choose to disable the automatic self-levelling mode. The Rugby always turns on in automatic mode regardless of the previous selection.



Pressing "OK" resets the laser back to a level plane.

1. Press and hold the +X or -X buttons to manually change grade. No value is displayed in the display.
2. To reset back to a flat laser plane: press the "OK" button.

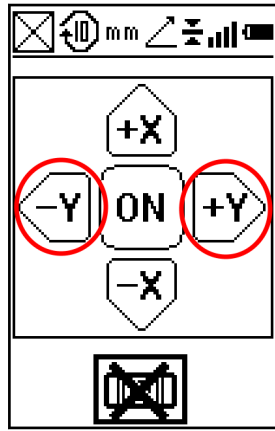

1. Press and hold the +Y or -Y buttons to manually change grade. No value is displayed in the display.
2. To reset back to a flat laser plane: press the "OK" button.

### Semi-automatic mode

In Semi-automatic mode the self-levelling function is turned off when a grade value is entered. The Semi-automatic mode is displayed instead of the normal grade screen.

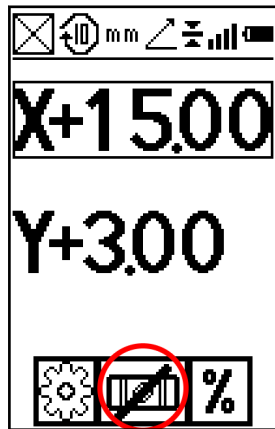

Semi-automatic mode

When using this mode, the Rugby first self-levels to the selected grade, then returns to manual mode.

### Display - Percent/Per Mil

You can select to display the grade in percent of grade or per mil:

- 1.000% = 1 metre rise per 100 metres
- 1.00‰ = 1 metre rise per 1000 metres

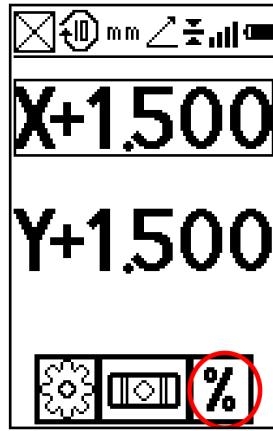

Display Percent

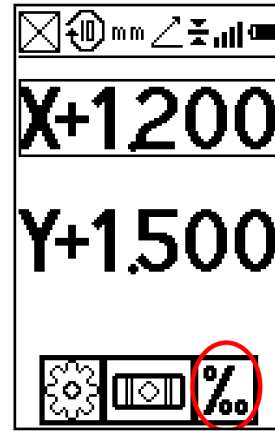

Display per Mil

Standard usage is percent of grade.

### Display - Thousandths or hundredths

You can select to display percent of grade in thousandths or hundredths:

- .000 - Standard usage is to display thousandths or three digits after the decimal point.
- .00 - If you choose to display hundredths, only two digits are displayed after the decimal point.

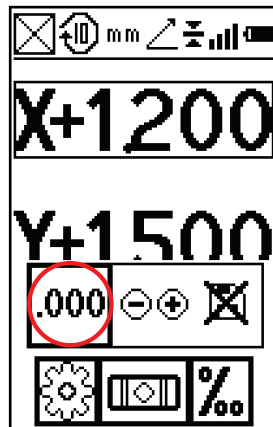

Display thousandths

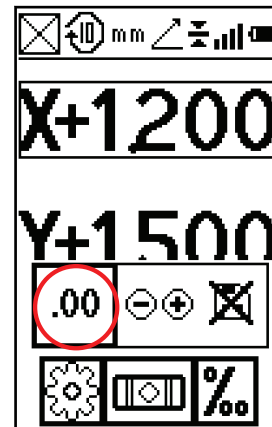

Display hundredths

### Save grade

Normally, the grade value is reset to 0.000% every time you turn on the Rugby.

If you prefer to display the previous grade settings when turning on the Rugby, you can enable the option **Save Grade**.

- Show 0.000: The grade settings are reset to 0.000% on power up (default).
- Show Grade: The previous grade settings are displayed on power up.

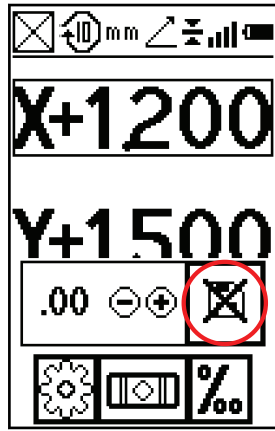

Save grade option disabled

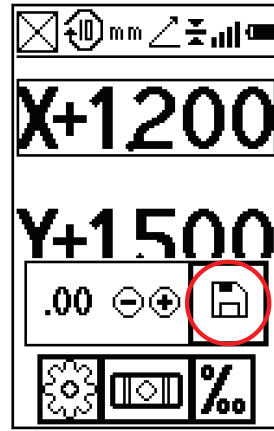

Save grade option enabled

## 5

## The Rod Eye Receivers

### 5.1

### Rod Eye 120, Receiver

#### Description

The Rugby can be sold with the Leica Rod Eye 120 receiver. Additional information on the receiver can be found in the individual User Manuals also on this CD.

#### Instrument components part 1 of 2



- a Level vial
- b Audio Speaker
- c LCD window
- d LEDs
- e Laser Reception window
- f Centre marking
- g Keypad

Component	Description
Level vial	Aids to keep the rod plumb when taking readings.
Audio Speaker	Indicates the detector's position: <ul style="list-style-type: none"> <li>• High - Fast beeping</li> <li>• On-grade - Solid tone</li> <li>• Low - Slow beeping</li> </ul>
LCD window	Front and rear LCD arrow indicate the detector's position.
LEDs	Display the relative position of the laser beam. Three channel indication: <ul style="list-style-type: none"> <li>• High - Red</li> <li>• On-grade - Green</li> <li>• Low - Blue</li> </ul>
Laser reception window	Detects the laser beam. The reception windows must be directed towards the laser.
Centre marking	Indicates the on-grade position of the laser.
Keypad	Power, accuracy and volume functions. Refer to <a href="#">Description of the buttons</a> for detailed information.

#### Instrument components part 2 of 2



- a Bracket mounting hole
- b Centre notch
- c Product label
- d Battery door

Component	Description
Bracket Mounting Hole	Location to attach the receiver bracket for normal operation.
Centre notch	Use to transfer reference marks. The notch is 85 mm (3.35") below to top of the detector.
Product label	The serial number is located inside the battery compartment.
Battery door	Refer to Chapter "Changing the alkaline batteries step-by-step" in Rod Eye 120 User Manual for detailed information.

## Description of the buttons



- a Power
- b Audio
- c Bandwidth

Button	Function
Power	Press once to turn on the receiver.
Audio	Press to change the audio output.
Bandwidth	Press to change detection bandwidth.

## Menu access and navigation

To access the menu of the Rod Eye 120 Receiver, press the Bandwidth button and Audio button simultaneously.

- Use the Bandwidth button and Audio button to change parameters.
- Use the Power button to scroll through the menu.

## 5.2

### Rod Eye 140, Classic Receiver

#### Description

The Rod Eye 140 Classic Receiver provides you with basic position information by using an arrow display.

#### Instrument components



- a Level vial
- b Audio Speaker
- c LCD window
- d LEDs
- e Laser reception window
- f Centre marking
- g Power button, Bandwidth button and Audio button

## Description of the buttons



- a Power
- b Audio
- c Bandwidth

Button	Function
Power	Press once to turn on the receiver.
Audio	Press to change the audio output.
Bandwidth	Press to change detection bandwidth.

## Menu access and navigation

To access the menu of the Rod Eye 140 Receiver, press the Bandwidth button and Audio button simultaneously.

- Use the Bandwidth button and Audio button to change parameters.
- Use the Power button to scroll through the menu.

## 5.3

### Rod Eye 160, Digital Receiver

## Description

The Rod Eye 160 Digital Receiver provides you with basic position information by using an arrow display plus digital readout.

## Instrument components

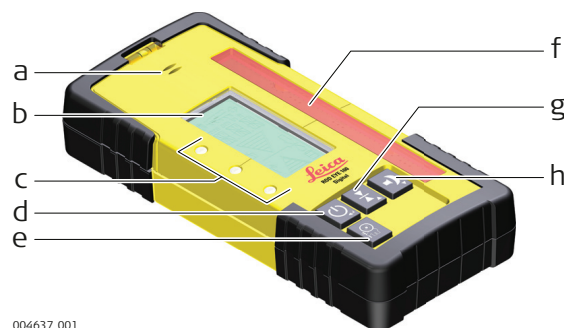

- a Speaker
- b LCD Digital Display
- c LED Display
- d Power button
- e Laser man button
- f Reception window
- g Bandwidth button
- h Audio button

## Description of the buttons

Button	Function
Power	Press once to turn on the receiver.
	Press 1.5 seconds to turn off the receiver.
Laser man	Press to capture the digital reading.
Bandwidth	Press to change detection bandwidths.
Audio	Press to change the audio output.

## Menu access and navigation

To access the menu of the Rod Eye 160 Digital Receiver, press the Bandwidth button and Audio button simultaneously.

- Use the Bandwidth button and Audio button to change parameters.
- Use the Power button to scroll through the menu.

# 6 Applications

## 6.1 Setting Forms

### Setting forms

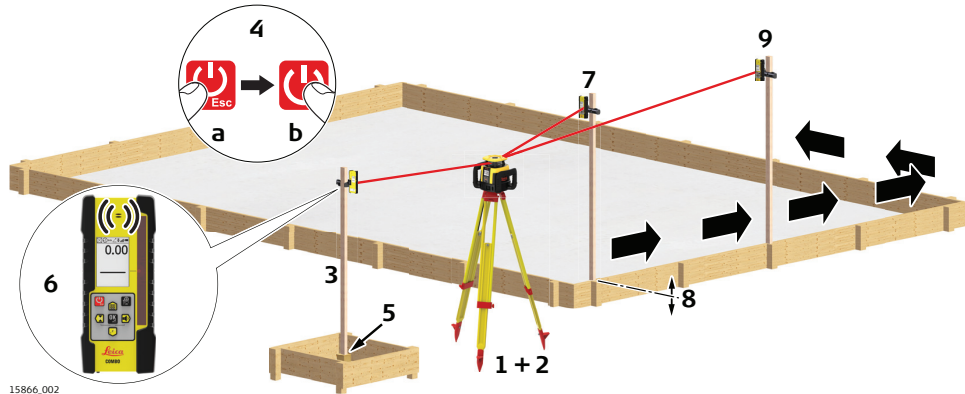

1. Set up the Rugby on a tripod.
2. Set up the tripod on a stable surface outside the working area.
3. Attach the Combo+ to a rod.
4. Turn on the Rugby and the Combo+.
5. Set the base of the rod on a known point for the finished height of forms.
6. Adjust the height of the Combo+ on the rod until the on-grade (centre-line) position is indicated on the Combo+ by:
  - the centre bar,
  - a solid audio tone,
  - the digital display.
7. Set the rod with the attached Combo+ on top of the form.
8. Adjust the height of the form until the on-grade position is again indicated.
9. Continue to additional positions until the forms are levelled to the rotating plane of the Rugby.

## Checking grades

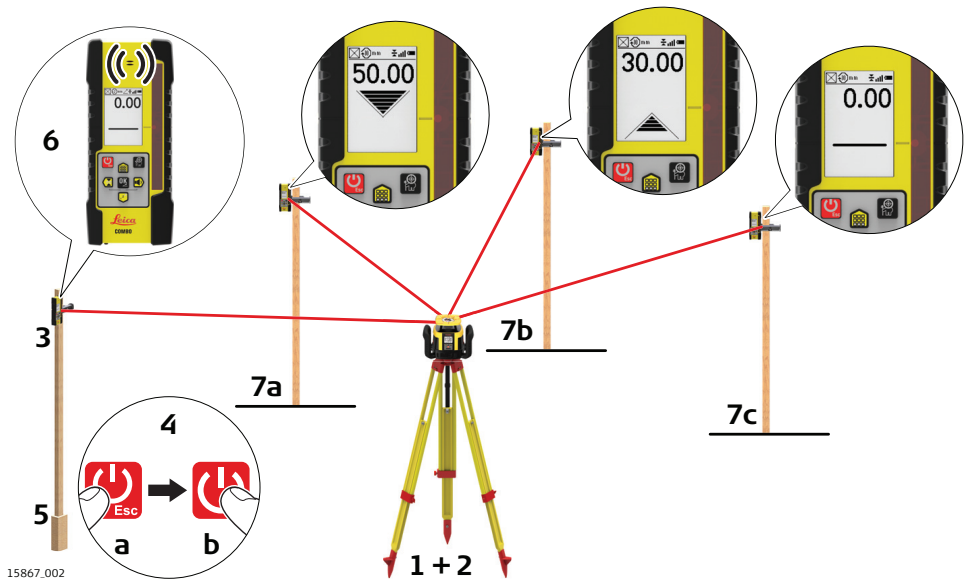

1. Set up the Rugby on a tripod.
2. Set up the tripod on a stable surface outside the working area.
3. Attach the Combo+ to a rod.
4. Turn on the Rugby and the Combo+.
5. Set the base of the rod on a known point for the finished grade.
6. Adjust the height of the Combo+ on the rod until the on-grade (centre-line) position is indicated on the Combo+ by:
  - the centre bar,
  - a solid audio tone,
  - the digital display.
7. Set the rod with the attached Combo+ on top of the excavation or concrete pour to check for correct elevation.
8. Variances can be read in precise measurements with the Combo+.
  - 7a: Position is too high.
  - 7b: Position is too low.
  - 7c: Position is on grade.

## 6.3

## Manual Grades

### 6.3.1

### Manual Grades

#### Manual grades

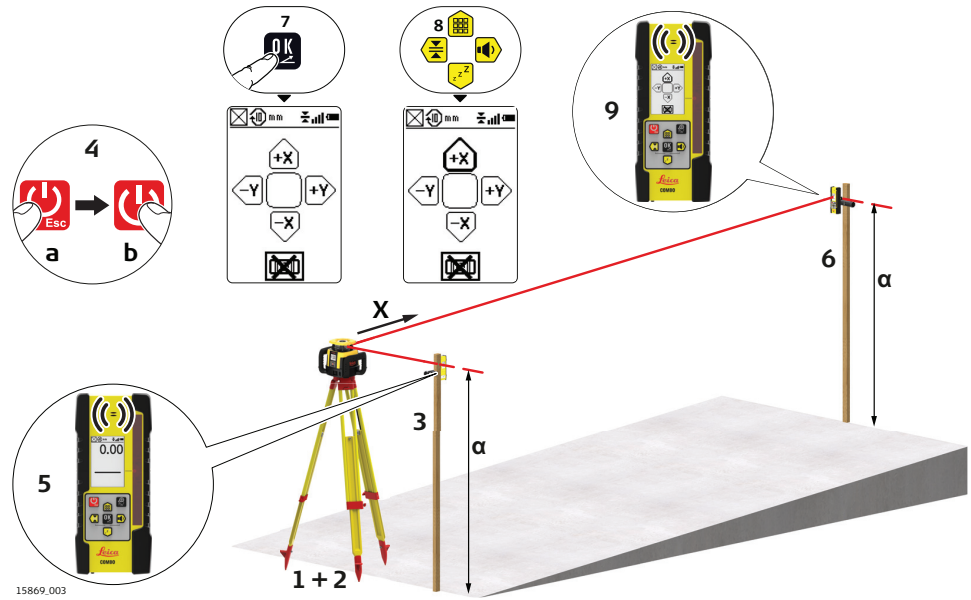



1. Set up the Rugby on a tripod.
2. Set up the tripod at the base of a slope with the x-axis pointing in the direction of the slope.
3. Attach the Combo+ to a rod.
4. Turn on the Rugby and the Combo+.
5. At the base of the slope, adjust the height of the Combo+ on the rod until the on-grade (centre-line) position is indicated on the Combo+ by:
  - the centre bar,
  - a solid audio tone,
  - the digital display.
6. Move the rod and the attached Combo+ to the top of the slope.
7. Change the levelling to Manual mode on the grade screen.
8. Use the Up/Menu and Down/Sleep buttons on the Combo+ to move the laser beam up and down.
9. Continue moving the beam until the on-grade (centre-line) position is indicated on the Combo+ by a constant audio tone.

## 6.3.2

## Manual Grades with Slope Adapter

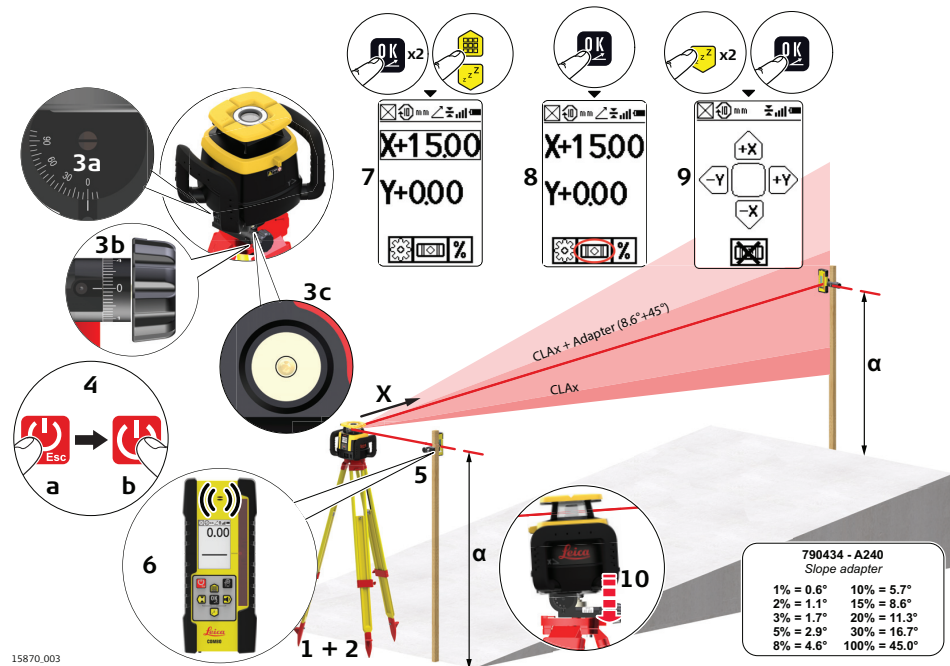
### Manual grades with slope adapter



1. Set up the Rugby and the slope adapter on a tripod.
  2. Set up the tripod at the base of the slope with the Rugby and the slope adaptor pointing in the direction of the desired slope.
  3. Set the slope adapter to the zero position on the bracket and on the knob. Roughly level the top of the tripod using the circular level on the slope adapter.
  4. Turn on the Rugby and Combo+.
  5. Attach the Combo+ to a rod.
  6. At the base of the slope, adjust the height of the Combo+ on the rod until the on-grade (centre-line) position is indicated on the Combo+ by:
    - the centre bar,
    - a solid audio tone.
  7. Enter maximum grade value. It is best practice to use the Rugby lasers grading to its limits before using the slope adapter.
  8. Press the OK/Grade button to confirm the grade entry.
  9. Set manual levelling. Manual levelling stops the laser attempting to re-level once the slope adapter is being used.
- Use the slope adapter to extend the grade capabilities of the laser.
-  The Combo+ can now be used to control the grade of the slope.

## 6.4

## Batter Boards

### Description

The Rugby and the Combo+ create a vertical plane of laser light that acts as a virtual string line for batter board setups.

Laser setup

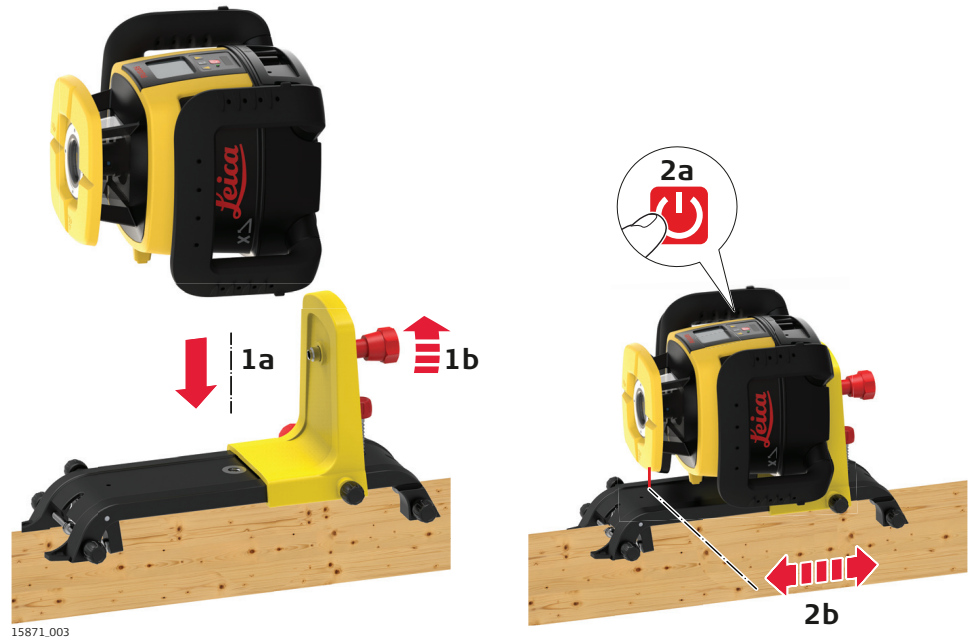

1. Mount the Rugby to the smart adapter and then the smart adapter to the batter board.

---

2. Turn on the Rugby. The laser beam will automatically point downwards so that the Rugby and the smart adapter can be positioned directly over the surveyed reference nail.

Combo+ setup

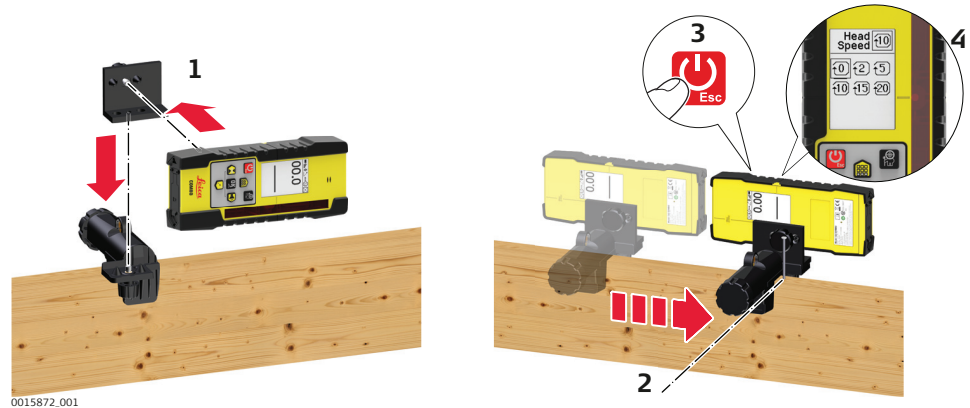

1. Mount the Combo+ to the Combo+ bracket using the 90° adapter.

---

2. Attach the bracket to the batter board. The top of the Combo+ bracket should be tight against the surveyed reference nail.

---

3. Turn on the Combo+.

---

4. Set the head rotation to the fastest speed. The speed depends on the laser model variant in operation.

## Alignment

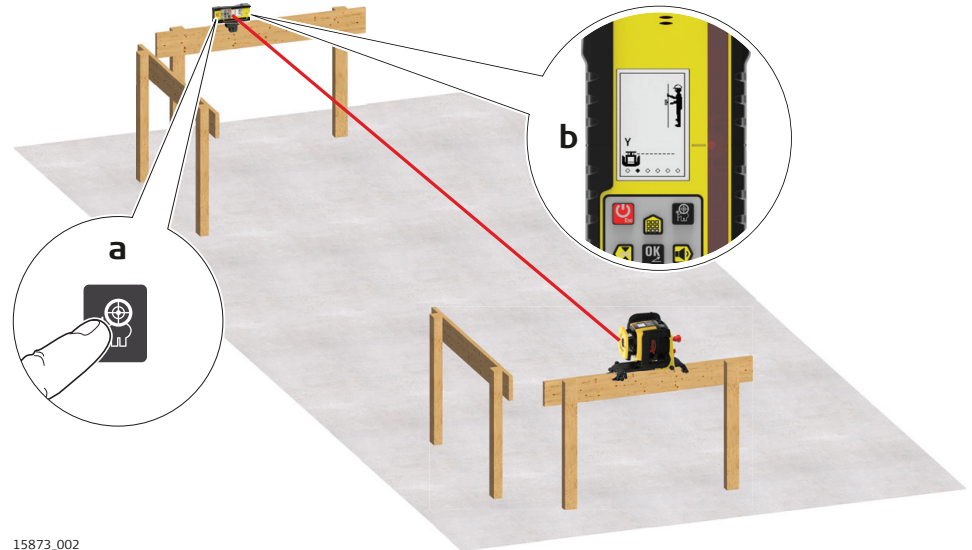

15873\_002

1. Use the Combo+ to move the rotating laser beam left or right until the Combo+ displays an on-grade position.

OR

1. Use the Slope Catch function of the Combo+ to automatically align the vertical rotating plane to the Combo+.

---

2. Press the Smart Target button on the Combo+.

---

3. Navigate to **Y Slope Catch** and press the OK/Grade button.

## Monitoring



The monitoring process allows for certain position deviations over time. An example of this is the slight positional changes that occur over the course of a day due to temperature fluctuations. Adjustments are made to the Y-axis to ensure the Combo+ and Rugby maintain the desired grade setting.

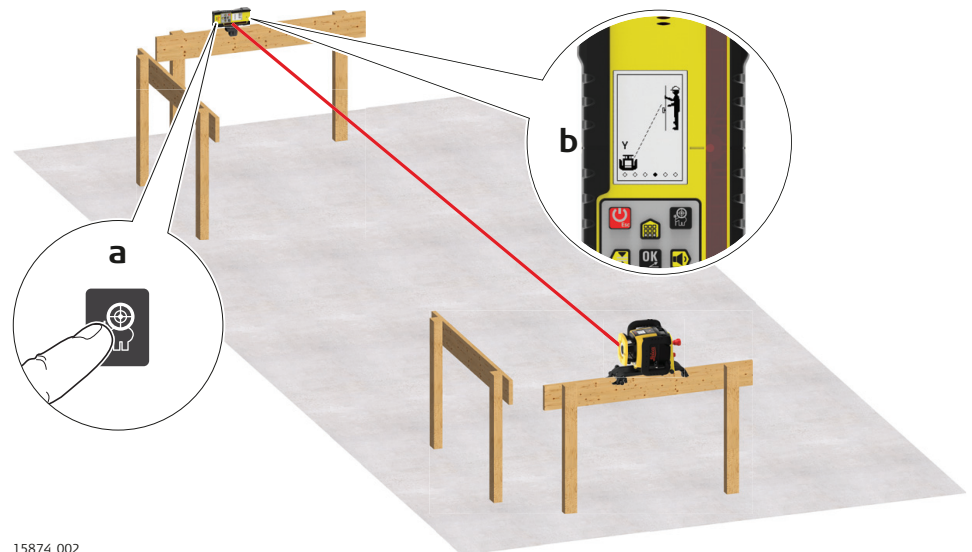

15874\_002

1. Use the Slope Catch function of the Combo+ to align and then monitor the laser beam automatically.

---

2. Press the Smart Target button on the Combo+.

3. Navigate to **Y Slope Lock** and press the OK/Grade button.

 The Combo+ notifies you when complete.

## 6.5

### Suspended Ceilings

#### Description

The Rugby can also be used for suspended ceiling installations.

#### Mounting the laser



1. Attach the Rugby to the SmartAdapter.

#### Application

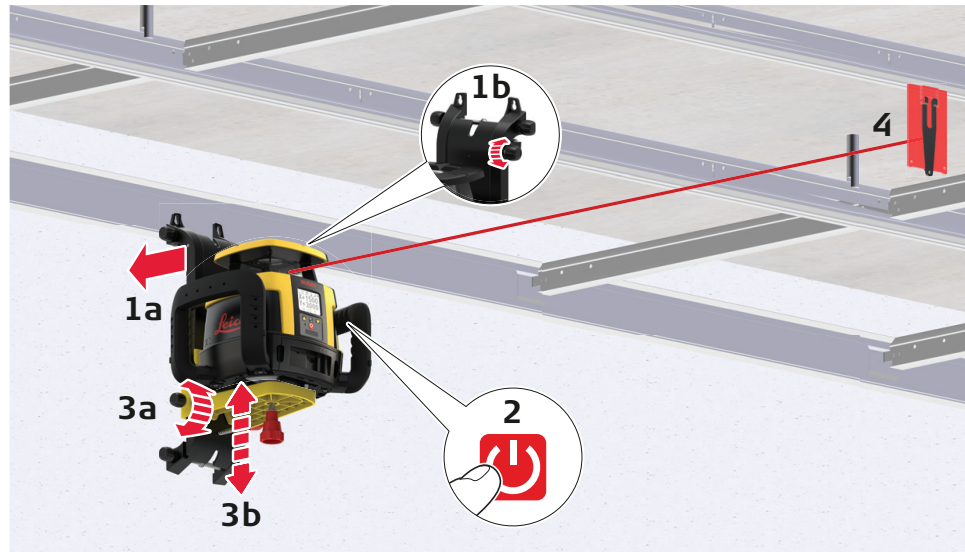

1. After mounting the first strip of ceiling trim at the desired height (centre position of the ceiling target) below, attach the SmartAdapter and Rugby to the trim. Tighten the locking knobs on the top of the SmartAdapter.
2. Press the Power button to turn on the Rugby and allow the Rugby to self-level.
3. Adjust the Rugby so that the rotating beam is at the desired height below the ceiling grid. Loosen the adjustment knob on the side of the SmartAdapter and slide the Rugby up or down. When at the desired height, tighten the adjustment knob.

4. Install the ceiling grid using the ceiling grid target and laser beam as your reference.

### Setup with the Combo+

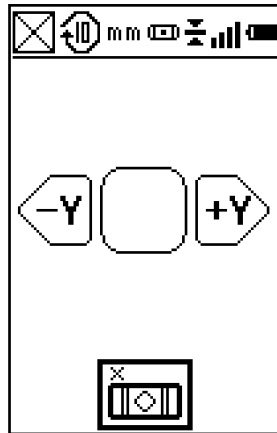

When installing suspended ceilings use the Combo+ to change to scanning mode for increased visibility.

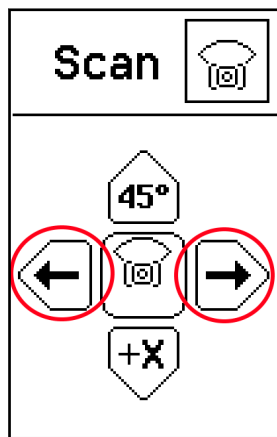

The scanning beam can be rotated using the left and right option on the Combo+.

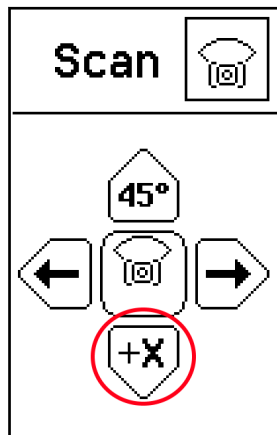

The scanning beam can be moved quickly in 90° increments using the Scan 90° option.

## 6.6

### Layout

#### Description

Lying on its side the Rugby can be used for laying out wall positions, squaring, transferring points and more.



Features shown depend on the laser model variant in operation. Refer to [2.2 Product Variants](#).

## Layout

The Rugby projects two laser beams at an angle of 90° to each other.

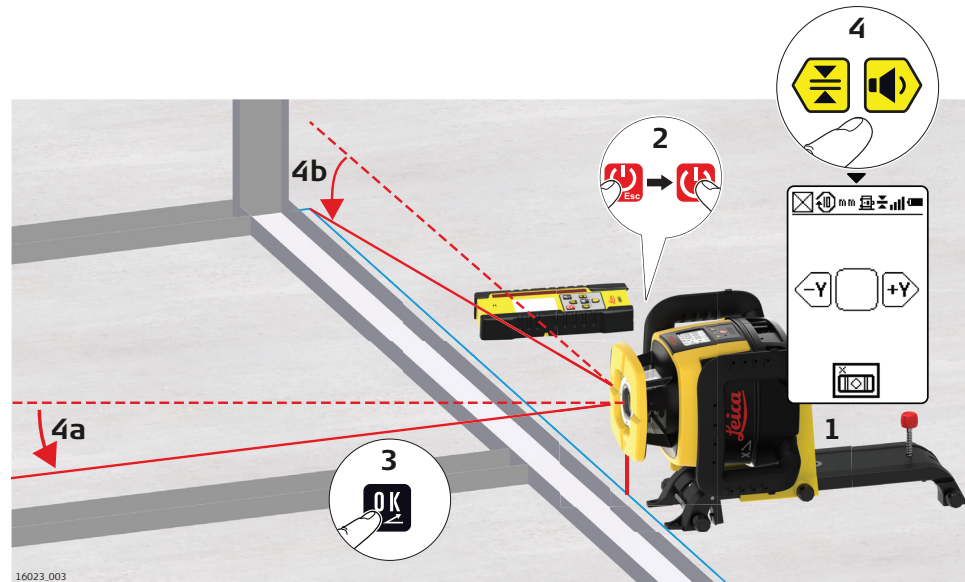

1. Attach the Rugby to the SmartAdapter and set it up lying on its side.

---

2. Press the Power/ESC button to turn on the Rugby. Allow the Rugby to self-level.  
 ☞ The Rugby will always turn on in Automatic Mode.

---

3. In sideways operation the laser beam points downwards for alignment over your reference automatically. Enter the grade screen on the Combo+ by pressing the OK/Grade button.

---

4. Roughly align the beam to a second control point. Using the Right/Volume and Left/Bandwidth buttons on the Combo+ to fine-tune the beam until striking the second control point.

---

- ☞ Once aligned the split beam and rotating beams can be used to locate 90° angles for layout. The rotating beam also creates a vertical plane for transferring points from the floor to the ceiling.

## Setup with the Combo+

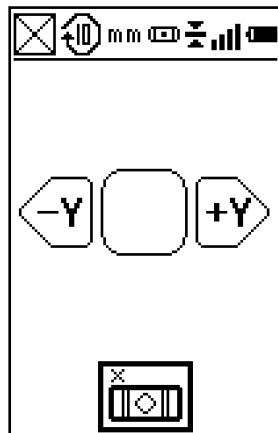

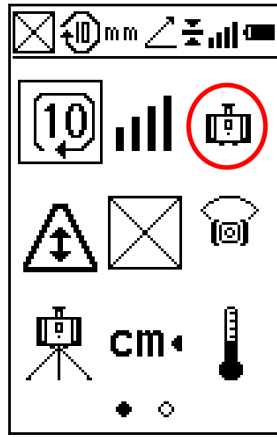

Press the Beam down option to check the alignment over a point.

## 6.7

### Layout with Slope Catch



Features shown depend on the laser model variant in operation. Refer to [2.2 Product Variants](#).

#### Layout with Slope Catch

The Rugby projects two laser beams at an angle of 90° to each other.

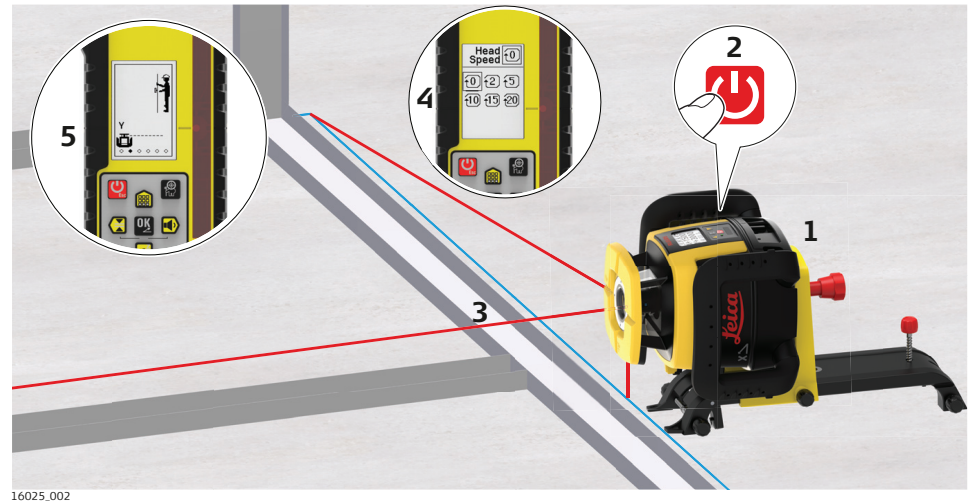

1. Attach the Rugby to the SmartAdapter and set it up lying on its side.
2. Press the Power button to turn on the Rugby. Allow the Rugby to self-level.
  - The Rugby will always turn on in Automatic Mode.
3. In sideways operation the laser beam points downwards for alignment over your reference automatically.
4. Start the head rotation or scanning motion to roughly align the beam to a second control point.
5. Press the Smart Target button, navigate to the Slope Catch feature and press the OK/Grade button.
  - When the Slope Catch process is complete, the Combo+ alerts you.



Once aligned the split beam and rotating beams can be used to locate 90° angles for layout. The rotating beam also creates a vertical plane for transferring points from the floor to the ceiling.

### 6.8.1

### Grade Dial-in with Combo+

#### Grade dial-in with Combo+

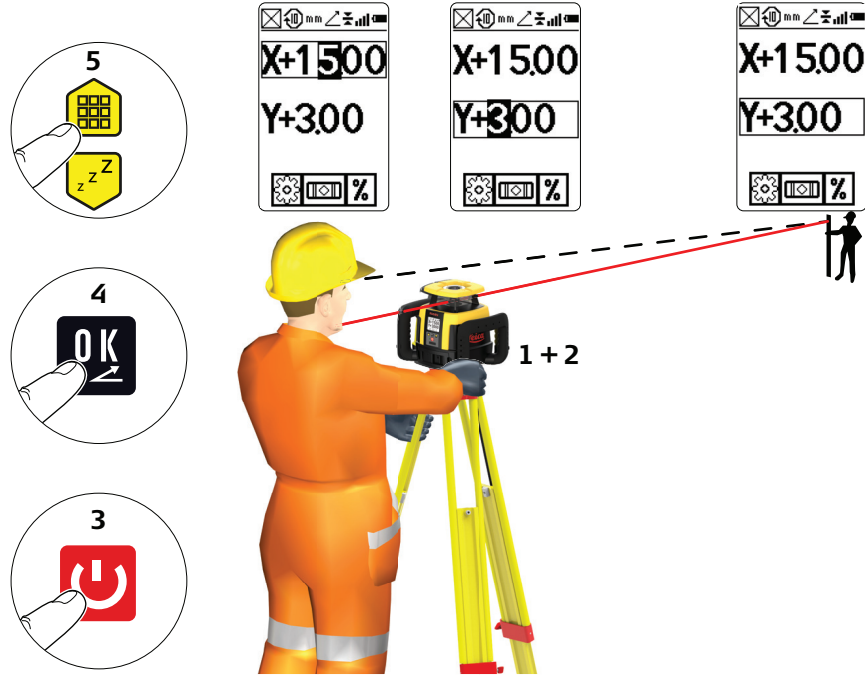

1. Set up the Rugby on a tripod.
2. Set up the Rugby and the tripod in line with one axis of the job and align the top of the Rugby in the direction of the axis.
3. Turn on the Rugby.
4. Press the OK/Grade button.
5. Press the Up/Menu button or Down/Sleep button to select an axis.
6. Press the OK/Grade button to confirm your selection.
7. Press the Up/Menu button or Down/Sleep button to edit a selected character.  
Press the Left/Bandwidth button and Right/Volume button to navigate the characters.
8. Press the Up/Menu button or Down/Sleep button to confirm.  
Once grade is entered, the Rugby begins to adjust to grade. Do not disturb the Rugby during this process.



The values flash while the self-levelling is in process.



Press the Up/Menu button and Down/Sleep button simultaneously to reset the grade value to zero while in grade entry mode.

## Grade dial-in with Rugby CLAx

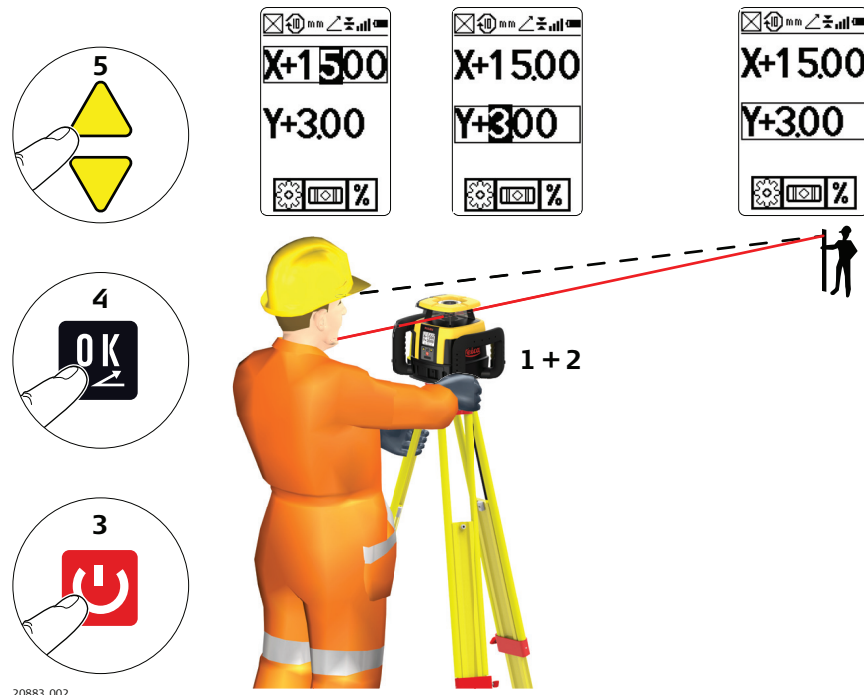

1. Set up the Rugby on a tripod.
2. Set up the Rugby and the tripod in line with one axis of the job and align the top of the Rugby in the direction of the axis.
3. Turn on the Rugby.
4. Press the OK/Grade button once to start the grade entry mode. The X-axis grade value will be highlighted.
5. Press the Down arrow button to select the Y-axis grade value.
6. Select the grade value.
7. Press the Up arrow button or Down arrow button to change the grade value.  
Press the OK/Grade button to confirm the selection or wait 10 seconds for auto confirmation.
8. Once grade is entered, the Rugby begins to adjust to grade. Do not disturb the Rugby during this process.
  - The values flash while the self-levelling is in process.
  - Press the Up arrow button and Down arrow button simultaneously to reset the grade value to zero while in grade entry mode.

## 6.9

## Slope Catch

## Slope Catch using the Combo+

Using the Slope Catch feature you can match an existing grade. The Rugby moves to the new grade position, displays the grade found (CLAx700) and begins self-levelling to maintain the grade over time. Maximum range is 100 m (300').

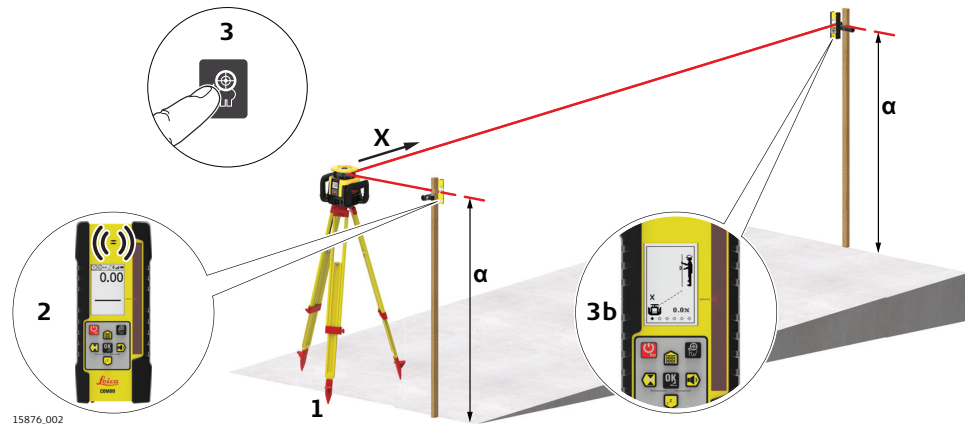

1. Set up the Rugby at the base of a slope with no grade dialled into the Rugby and with the X-axis pointing in the direction of the slope.
2. Adjust the height of the Combo+ on the rod at the base of the slope until the on-grade (centreline) position is indicated on the Combo+ by:
  - the centre bar,
  - a solid audio tone,
  - the digital display.
3. Move the rod with the Combo+ to the top of the slope. To start the Slope Catch process, press the Smart Target button and select the first option.

The Rugby searches for the Combo+ until the on-grade position is found. Once the on-grade position is found, the Combo+ screen displays a tick and the Combo+ returns to normal operation.

4. After this signal, the Combo+ can be moved and used as normal. The grade for the sloped axis is displayed on the screen and the Rugby now self-levels to this new slope.

☞ To use Slope Catch for the Y-axis, press the Smart Target button and choose the second option. The process is identical.

☞ You can set up either one or both axes by using this procedure.

## 6.10

### Slope Lock

#### Slope Lock using Combo+

Using the Slope Lock feature, you can match an existing grade. The Rugby moves to the new grade position, displays the grade found (CLAx700) and begins self-levelling to maintain the grade over time. Maximum range is 100 m (300').

Press the Smart Target button and select option 3 or 4 to begin the lock mode. The Combo+ must remain in place to monitor any movements of the rotating beam. Thus, an accurate grade setup is maintained.

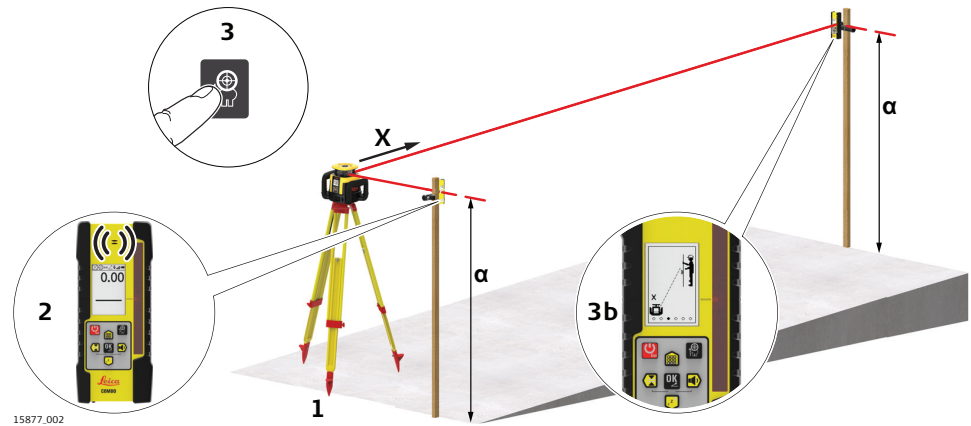

1. Ensure that the grade value is set to zero. Set up the Rugby at the base of a slope with the X-axis pointing in the direction of the slope.

---

2. At the base of the slope, adjust the height of the Combo+ on the rod until the on-grade (centreline) position is indicated on the Combo+ by:
  - the centre bar,
  - a solid audio tone,
  - the digital display.

---

3. Press the Smart Target button and select option 3 to begin the lock mode X-axis slope catching and lock process.
 

The Rugby searches for the Combo+ until the on-grade position is found. Once the on-grade position is found, the Combo+ displays a tick on the screen.

---

4. After this signal, the Combo+ must remain in place to monitor any movements of the rotating beam. The grade for the sloped axis is displayed on the screen of the Rugby.

---

-  To use Slope Lock for the Y-axis, press the Smart Target button and select option 4. The process is identical.

---

-  Using this procedure, you can set up either one or both axes.

---

-  To turn off lock mode on the Combo+, press the Power/ESC button.

---

-  To lock and monitor the rotating beam of an existing grade, mount the Combo+ in the plane of the laser before starting the Slope Lock procedure.

## 6.11

### Automatic Axis Alignment

#### Description

The automatic axis alignment electronically adjusts the axes of the Rugby to your grade stakes. The procedure is the same as the procedure described in [3.7 Precise Alignment of the Axes](#) - except that the alignment is done electronically, using the Combo+.

For the automatic axis alignment, it is only necessary to position the Rugby and Combo+ in line with two grade stakes and to start the procedure. It is only possible to directly change the X-axis in this way. The following steps are done automatically:

- The Rugby searches for the Combo+ on the X-axis until it is found and locked on grade.
- Once found, the Rugby drives grade into the Y-axis and monitors the position of the beam on the Combo+.

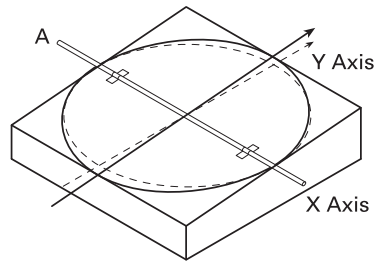

- The Rugby electronically compensates for any misalignment by adjusting the beam until it is again locked on the Combo+.
- The procedure is then complete and the Rugby returns to the grades that you entered. The Rugby is now properly aligned.

## Automatic Axis Alignment

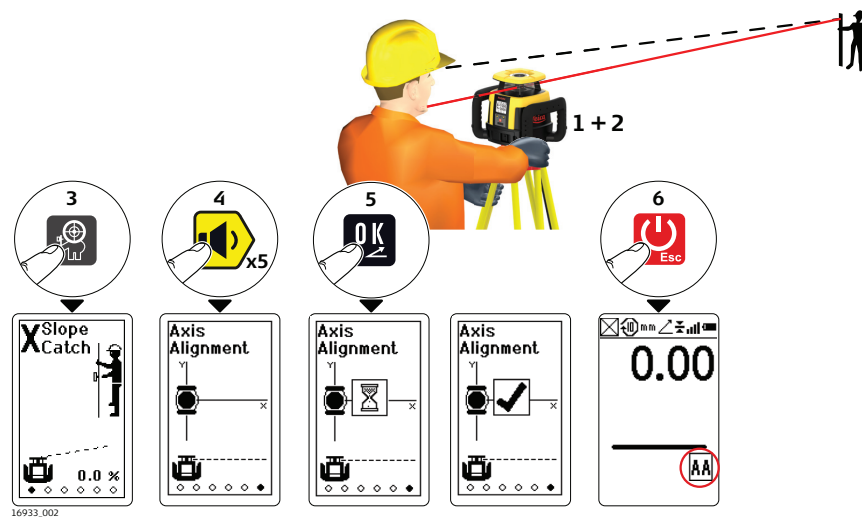

1. Setup the Rugby on a tripod at point A, on the axis to be aligned. Adjust the axis by rotating the Rugby by hand and observing the alignment marks on the top of the Rugby, until it is approximately aligned.
2. With the Combo+ in hand, enter the grade values for the X-axis and Y-axis, if needed. Then, move with the Combo+ in the direction the Rugby should align itself with.
3. Press the Smart Target button to select a Smart Target feature.
4. Select **Axis Alignment** by navigating the menu.
5. With **Axis Alignment** selected, press the OK/Grade button. The Rugby starts to search for the Combo+. An hourglass is displayed for up to two minutes, while the process is running. When the process is complete, a tick icon indicates success, or a cross for failure.
6. When the **Axis Alignment** screen has been exited, the **AA** icon indicates the axis has been modified.

- ☞ Ensure that the Combo+ is held steady until the procedure is complete.
- ☞ The Axis Alignment modifications do not persist after the Rugby has been turned off.

### Information screens during alignment procedure

During and after the alignment procedure the Rugby displays information screens to indicate the status of the procedure. During the alignment procedure, the WAIT screen is displayed.

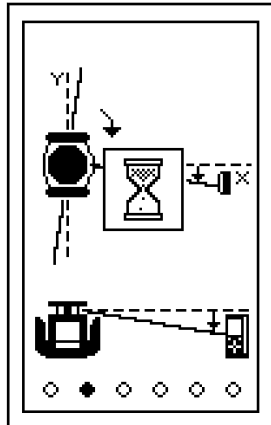

When the alignment procedure is successful, the Combo+ displays the tick symbol. Returning to the main screen resumes normal operation, with a small AA to indicate the position of the axes has been modified.

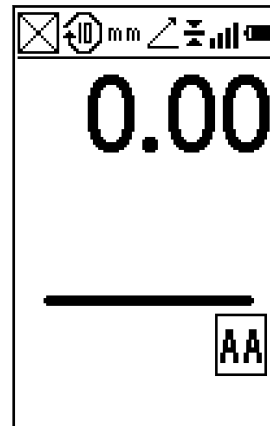
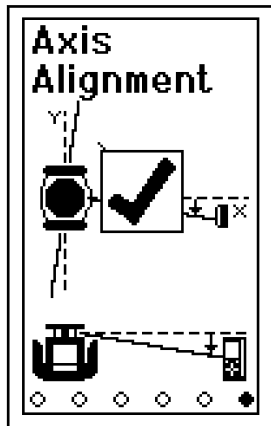

If the alignment procedure is not successful, the Combo+ displays the error symbol.

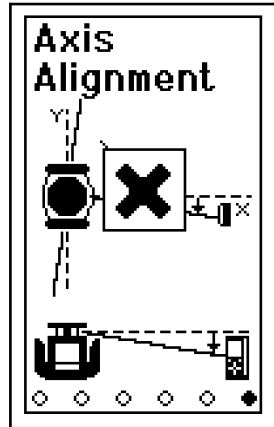

---

## 6.12

### Axis Alignment plus Slope Lock

#### Axis Alignment plus Slope Lock

If you also want the Combo+ to monitor the beam after the axis alignment, you have to place the Combo+'s on-grade position exactly in the plane of the laser and start the Slope Lock process.

Refer to [6.10 Slope Lock](#).

---

## 6.13

### Dual Combo+ Setups

#### Dual Combo+ setups using the Rugby

It is possible to use the Smart Target features of the Combo+ to catch and lock both axes of the laser. To do this, perform the actions above for the first axis, and then repeat the actions for the second axis using a second Combo+.



Once the Slope Lock process is started, the Combo+s must remain in place.

---

## 6.14

### More Applications

#### Interior applications

- Suspended ceilings
- Walls and partitions
- Vertical alignment
- Transferring points from floor to ceiling
- Vertical plumb
- Layout of floors
- Squaring of angles
- Setting cabinets
- Chair rails and wainscoting
- Alignment of wall and floor tiles
- Trim carpentry
- Setting sprinkler head heights
- Sloped ceilings

**Exterior applications**

- Setting elevation of forms and footings
  - Squaring of forms
  - Checking elevations and benchmarks
  - Landscaping
  - Drainage and septic systems
  - Fences and retaining walls
  - Decks and patios
  - Simple driveways or small parking lots
  - Facade Installations
  - Batter board setups
  - Road levelling
  - Rail levelling
  - Land levelling
-

## 7

## Batteries

### First-time use/ charging batteries

- The battery must be charged before using it the first time, because it is delivered with an energy content as low as possible or might be in sleep mode.
- The permissible temperature range for charging is from 0 °C to +40 °C/ +32 °F to +104 °F. For optimal charging, we recommend charging the batteries at a low ambient temperature of +10 °C to +20 °C/+50 °F to +68 °F if possible
- It is normal for the battery to become warm during charging. Using the chargers recommended by Leica Geosystems, it is not possible to charge the battery once the temperature is too high
- For new batteries or batteries that have been stored for a long time (> three months), it is effectual to make a discharge/charge cycle
- For Li-Ion batteries, a single discharge/charge cycle is sufficient. We recommend carrying out the process when the battery capacity indicated on the charger or on a Leica Geosystems product deviates significantly from the actual battery capacity available.

### Operation/discharging

- The batteries can be operated from -20 °C to +55 °C/-4 °F to +131 °F
- Low operating temperatures reduce the capacity that can be drawn; high operating temperatures reduce the service life of the battery

## 7.1

### Battery for Rugby

#### Charging the Li-Ion battery pack

The rechargeable Li-Ion battery pack on the Rugby can be charged without removing the battery pack from the Rugby.



1. Slide the locking mechanism on the battery pack to the left to expose the charge jack.
2. Plug the AC connector into the appropriate AC power source.
3. Connect the charger plug into the charge jack on the Rugby battery pack.
4. The small LED next to the charge jack flashes indicating that the Rugby is charging. The LED is on solid when the battery pack is fully charged.

5. When the battery pack is fully charged, disconnect the charger plug from the charge jack.



---

  6. Slide the locking mechanism to the centre position to prevent dirt from getting into the charging jack.
-  The battery pack reaches a full charge in approximately five hours if completely empty. A one-hour charge should allow the Rugby to run for a full eight hours.
- 

### Changing the Li-Ion battery pack

With the rechargeable Li-Ion battery pack, the battery indicator on the Rugby LCD display shows when the battery pack is low and must be charged. The charge indicator LED on the battery pack indicates when the battery pack is being charged (flashing slowly) or fully charged (on, not flashing).



-  The battery pack is inserted in the front of the Rugby.
- 
-  The battery pack can be charged without being removed from the Rugby. Refer to [Charging the Li-Ion battery pack](#).
- 
1. Slide the locking mechanism on the battery pack to the right and open the cover of the battery pack.

---

  2. To remove the battery pack: Remove the battery pack from the battery compartment.

---

  - To insert the battery pack: Insert the battery pack into the battery compartment.

---

  3. Close the cover of the battery pack and slide the locking mechanism to the left centre position until it locks into position.
-

## 7.2

## Battery for Combo+

### Charging the Li-Ion battery step-by-step

### Charging with charger A100



0016071.001

 Only use the charger delivered with the Rugby/Combo+ package.

1. Open the cover to expose the charge jack.
2. Plug the AC connector into the appropriate AC power source.
3. Connect the charger plug into the charge jack.
4. When the Combo+ is fully charged, disconnect the charger plug from the charge jack.
5. Close the cover to prevent dirt from getting into the charging jack.

### Charging with power bank or other USB source

1. Open the cover to expose the USB-C port.
2. Plug the USB cable into the power bank or other USB source.
3. Connect the USB plug into the USB-C port.
4. When the Combo+ is fully charged, disconnect the USB plug from the USB-C port.
5. Close the cover to prevent dirt from getting into the USB-C port.

## 8

# Accuracy Adjustment

### About

- It is the responsibility of the user to follow operating instructions and to periodically check the accuracy of the laser and work as it progresses.
- The Rugby is adjusted to the defined accuracy specification at the factory. It is recommended to check the laser for accuracy upon receipt and periodically thereafter to ensure accuracy is maintained. If the laser requires adjustment, contact your nearest authorised service centre or adjust the laser using the procedures described in this chapter.
- Only enter the accuracy adjustment mode when you plan to change the accuracy. Accuracy adjustments should only be performed by a qualified individual that understands basic adjustment principles.
- It is recommended to perform this procedure with two people on a relatively flat surface.

### 8.1

## Checking the Self-Levelling Accuracy

### Checking the self-levelling accuracy

1. Place the Rugby on a flat, level surface or tripod approximately 30 m (100 ft) from a wall.

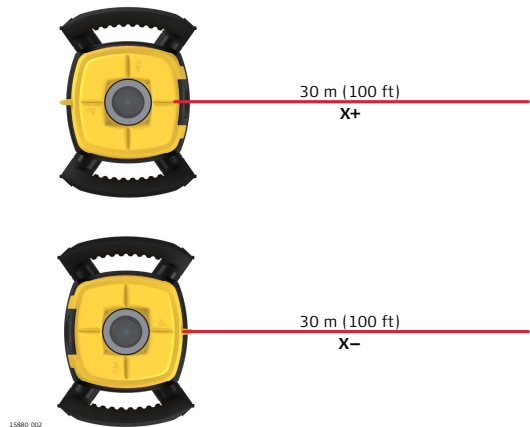

2. Align the first axis so that it is square to a wall. Allow the Rugby to self-level completely (approximately 1 minute after the Rugby begins to rotate).
3. Mark the position of the beam.
4. Rotate the laser 180° and allow it to self-level.
5. Mark the opposite side of the first axis.

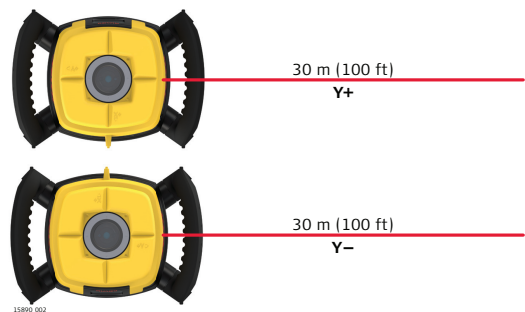

6. Align the second axis of the Rugby by rotating it 90° so that this axis is square to the wall. Allow the Rugby to self-level completely.
7. Mark the position of the beam.

8. Rotate the laser 180° and allow it to self-level.

9. Mark the opposite side of the second axis.



The Rugby is within its accuracy specification if the four marks are within  $\pm 1.5$  mm ( $\pm 1/16$ " ) from the centre.

## 8.2

### Adjusting the Self-Levelling Accuracy

#### Description

In calibration mode the X-axis calibration screen indicates changes to the X-axis.

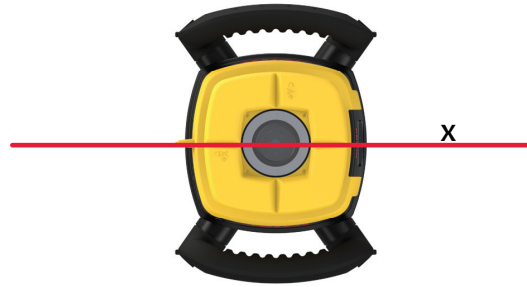

15891.002

The Y-axis calibration screen indicates changes to the Y-axis.

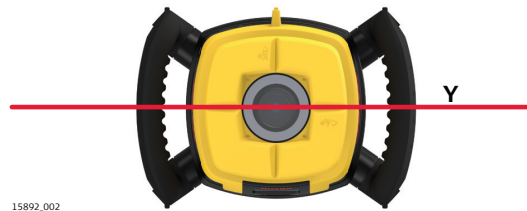

15892.002

#### Entering calibration mode step-by-step

1. Enter the calibration menu.  
Enter the calibration menu and select **XY Calibration**. Refer to [4.3.3 Menu Set 2-Calibration](#).

2. Press the OK/Grade button to switch from the X-axis to the Y-axis screen.

3. Modify the values as appropriate.



In Calibration mode, the LED does not blink and the laser head continues to rotate.

#### Calibrating the X-axis step-by-step

When entering Calibration mode, the X-axis calibration screen appears:

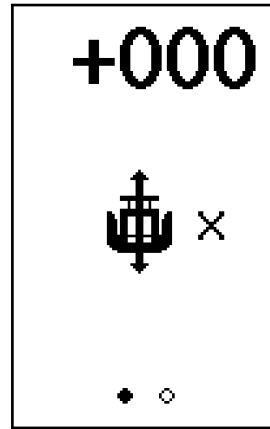

1. Check both sides of the X-axis.

---

2. Press the Up/Menu button and Down/Sleep button to modify the calibration value.
  - ☞ Each step represents approximately 2 arc seconds of change. Therefore, 5 steps equal approximately 1.5 mm at 30 m (1/16" at 100').

---

3. Press the OK/Grade button to accept the adjusted position and to switch to the Y-axis calibration screen.

### Calibrating the Y-axis step-by-step

After calibration of the X-axis, the Y-axis calibration screen appears:

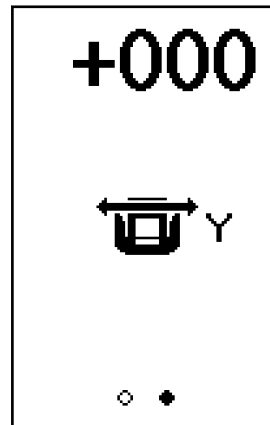

1. Check both sides of the Y-axis.

---

2. Press the Up/Menu button and Down/Sleep button to modify the calibration value.
  - ☞ Each step represents approximately 2 arc seconds of change. Therefore, 5 steps equal approximately 1.5 mm at 30 m (1/16" at 100').

---

3. Press the OK/Grade button to accept the adjusted position and exit the calibration screen.

### Exiting calibration mode

Press the OK/Grade button to accept the adjusted position and exit the calibration screen.



Press the Power/ESC button quickly at any time while in calibration mode to exit the mode without saving changes.

### 8.3

## Adjusting the Vertical Accuracy

### Entering calibration mode for the Z-axis step-by-step

1. Enter the calibration menu.
2. Put the Rugby in laydown position.
3. Modify the Z-axis as appropriate.



In Calibration mode, the LED does not blink and the laser head continues to rotate.

### Calibrating the Z-axis

When entering calibration mode for the Z-axis, the Z-axis calibration screen appears:



16017\_002

Rugby laying down position

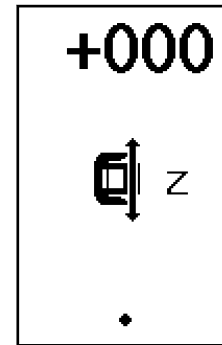

Combo+ Z-axis calibration screen

1. Press the Up/Menu button and Down/Sleep button to modify the calibration value.
2. Continue to press the Up/Menu button and Down/Sleep button and monitor the beam until the Rugby is within the specified range.
3. Press the OK/Grade button to accept the adjusted position and exit the calibration screen.



Press the Power/ESC button quickly at any time while in calibration mode to exit the mode without saving changes.

## 9

# Semi-Automatic Calibration

### About

This procedure is unique to the Rugby lasers and uses the digital readout of the Combo+ to measure, then adjust the plane of each axis. This procedure is an alternative to the traditional method described in [8 Accuracy Adjustment](#).

### Description

Objective: To rotate the Rugby to all four axes, then allow the Combo+ to adjust the beam automatically.

### Setup

1. Pair the Combo+ to the laser if not already done. Refer to [4.2 Connecting Screens for the Combo+](#).
2. Mount the laser on a flat, level surface or tripod.
3. Turn on the laser and align the X-axis toward the Combo+ position.
4. Mount the Combo+ to a fixed position, for example a stationary grade rod, approximately 30 metres (100 ft) from the laser.
5. Turn on the Combo+ and position the height of the Combo+ near or at the on-grade position. It is not necessary to be exact.
6. Enter the calibration screen within the menu and proceed with the semi auto cal.  
Enter the calibration menu and select **Semi-Automatic Calibration**. Refer to [4.3.3 Menu Set 2-Calibration](#).
7. An animation shows the necessary steps to follow.
8. Monitor the process on the screen until completion.



- With each rotation it may take up to 10 seconds for the calibration process to identify the axis being checked. Note the displayed screen indications.
- Each step of the process is very exact and may take 1 minute to complete before the ROTATE screen is displayed.
- It is important to note the screen indications to know the status of each axis in the process.
- It is not necessary to follow the steps in the exact order, but different rotation sequences result in different screen indications.
- Increasing the distance between the laser and Combo+ beyond 30 metres (100 ft) does not increase the accuracy of the calibration process.

### Calibrating

#### Step 1 - Align the X-axis (X+) towards the Combo+

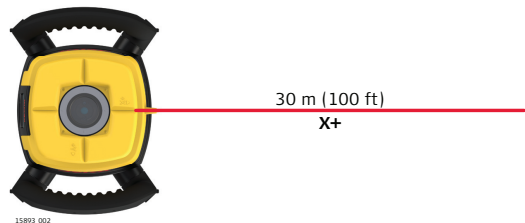

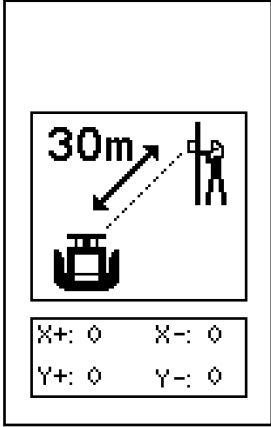
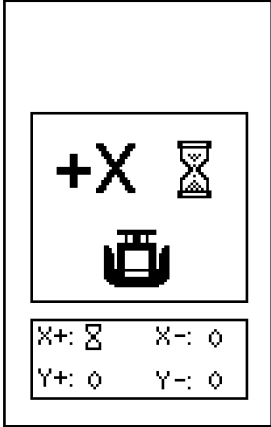
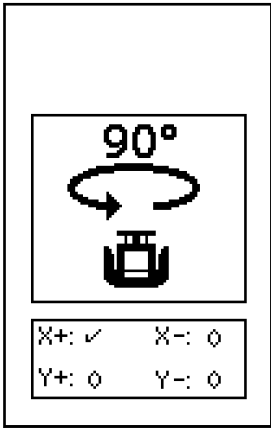
Screen Indication	Description
	<p>Prior to and during alignment, the Combo+ displays guidance animations to assist the user.</p> <p>Once the alignment process has begun for the <b>first</b> specified axis, an hour glass icon indicates the overall progress of the alignment.</p>
	
	<p>When the axis is successfully aligned, a tick icon can be seen below, in place of the hour glass shown earlier. Additionally, the Rugby will beep to confirm the success of the alignment.</p> <p>Following this, the animation will suggest rotating the Rugby 90° counter-clockwise, but rotating the Rugby 90° clockwise or 180° would also be sufficient.</p>

**Step 2 - Rotate the Rugby 90° and align Y-axis (Y-) towards the Combo+**

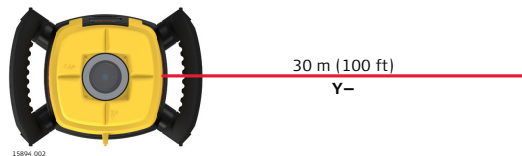

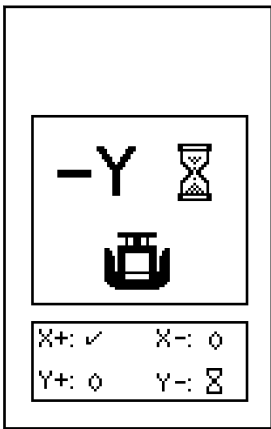
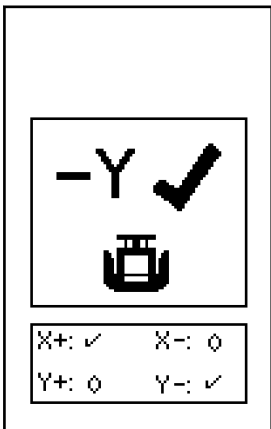
Screen Indication	Description
	<p>Once the alignment process has begun for the <b>second</b> specified axis, an hour glass icon indicates the overall progress of the alignment.</p> <p>When the axis is successfully aligned, a tick icon can be seen below, in place of the hour glass shown earlier. Additionally, the Rugby will beep to confirm the success of the alignment.</p>
	

**Screen Indication**

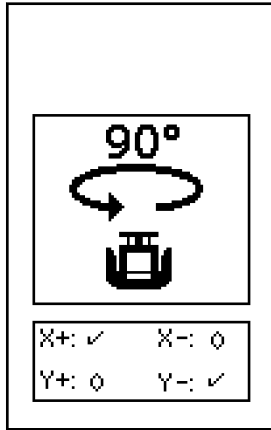

**Description**

Following this, the animation will suggest rotating the Rugby 90° counter-clockwise, but rotating the Rugby 90° clockwise or 180° would also be sufficient. The aim is to align with an axis not previously selected during the process.

**Step 3 - Rotate the Rugby 90° and align X-axis (X-) towards the Combo+**

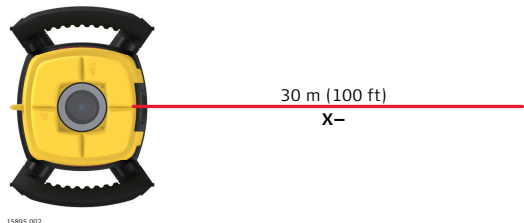

**Screen Indication**

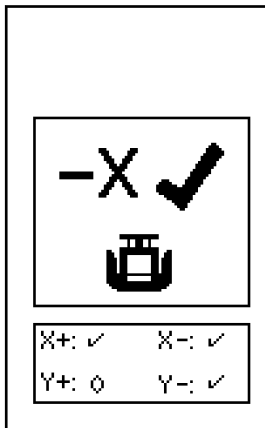
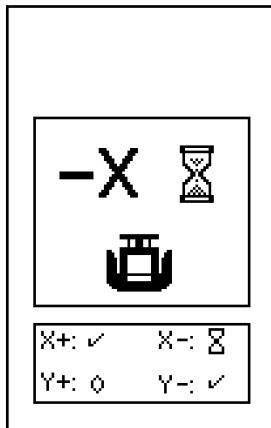

**Description**

Once the alignment process has begun for **third** specified axis, an hour glass icon indicates the overall progress of the alignment. When the axis is successfully aligned, a tick icon can be seen below, in place of the hour glass shown earlier. Additionally, the Rugby will beep to confirm the success of the alignment.

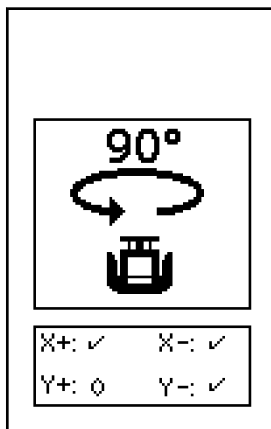

Following this, the animation will suggest rotating the Rugby 90° counter-clockwise, but rotating the Rugby 90° clockwise or 180° would also be sufficient. The aim is to align with an axis not previously selected during the process.

**Step 4 - Rotate the Rugby 90° and align Y-axis (Y+) towards the Combo+**

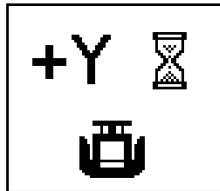
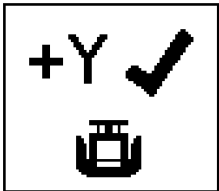

Screen Indication	Description									
 <table border="1" data-bbox="491 766 711 850"> <tr> <td>X+: ✓</td> <td>X-: ✓</td> </tr> <tr> <td>Y+: ⌚</td> <td>Y-: ✓</td> </tr> </table>	X+: ✓	X-: ✓	Y+: ⌚	Y-: ✓	 <table border="1" data-bbox="790 766 1010 850"> <tr> <td>X+: ✓</td> <td>X-: ✓</td> </tr> <tr> <td>Y+: ✓</td> <td>Y-: ✓</td> </tr> </table>	X+: ✓	X-: ✓	Y+: ✓	Y-: ✓	<p>Once the alignment process has begun for the <b>fourth and final</b> specified axis, an hour glass icon indicates the overall progress of the alignment.</p> <p>When the axis is successfully aligned, a tick icon can be seen below, in place of the hour glass shown earlier.</p>
X+: ✓	X-: ✓									
Y+: ⌚	Y-: ✓									
X+: ✓	X-: ✓									
Y+: ✓	Y-: ✓									





**Calibration successful:**



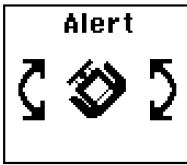
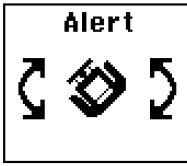

When all four axes have been checked and the calibration process was successful, the Rugby beeps for 3 seconds and all the axes show a tick mark below. Following the successful alignment, the laser will turn off.

**Calibration not successful:**

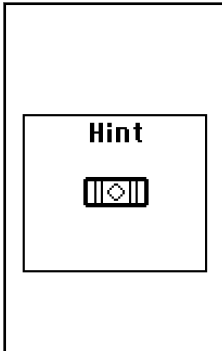

If the Rugby encounters a problem and the calibration process was not successful, the Rugby returns to the main screen and the Combo+ returns to the calibration menu screen.

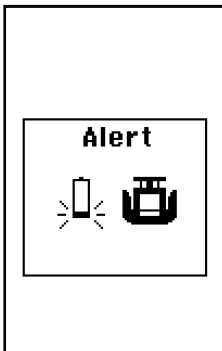
Alerts and message screens

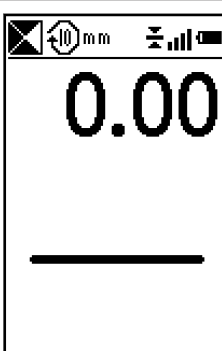
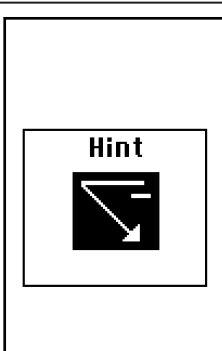
Alert	Symptom	Possible causes and solutions
	<p>Low battery indication on the display.</p>	<p>The batteries are low. Recharge the Li-Ion battery pack. Refer to <a href="#">7 Batteries</a>.</p>
	<p>Elevation (H.I.) Alert: The Elevation (H.I.) Alert screen is shown and the audio beeps.</p>	<p>The Rugby has been bumped or tripod was moved. Turn off Rugby to stop alert, check the height of the laser before beginning to work again. Allow Rugby to re-level and check the height of the laser. After 2 minutes in the alert condition, the unit will shut off automatically.</p>
	<p>Servo Limit Alert The servo limit alert screen is shown.</p>	<p>The Rugby is tipped too far to reach a level position. Reposition the Rugby within the 6 degree self-levelling range. After 2 minutes in the alert condition, the unit will shut off automatically.</p>
	<p>Tilt Alert The tilt alert screen is shown.</p>	<p>The Rugby is tipped more than 45° from level. After 2 minutes in the alert condition, the unit will shut off automatically.</p>
	<p>Temperature Alert The temperature alert screen is shown.</p>	<p>The Rugby is in an environment where it cannot operate without damaging the laser diode, for example being exposed to the heat from direct sunlight. Shade the Rugby from the sun. After 2 minutes in the alert condition, the unit will shut off automatically.</p>

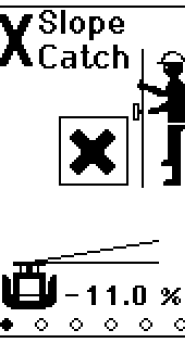
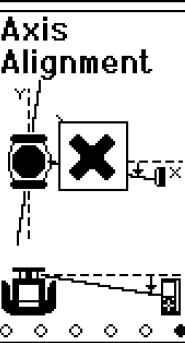
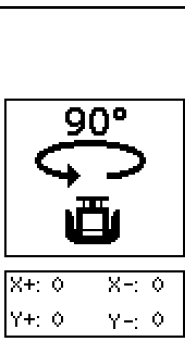
Alert	Symptom	Possible causes and solutions
	<p>The temperature check alert screen is shown.</p>	<p>The Rugby has detected a change in temperature of 5 °C and is checking the level position.</p> <p> Wait until procedure is complete. Refer to <a href="#">4.3.2 Menu Set 1-Temperature sensitivity</a> for changing the setting between 5 °C, 2 °C or to disable.</p>
	<p>The “empty battery” icon flashes.</p>	<p>The Rugby has reached a low battery state and changes the head speed to 7 rps. If the Combo+ detects the Rugby rotating at 7 rps, it displays a low battery alert.</p> <p> Check the battery of the Rugby.</p> <p> During this state, the Smart Target features are disabled.</p>
	<p>The beam is not emitting from all sides of the laser.</p>	<p>Beam masking is activated for two or more sides of the laser. To de-activate or change beam masking, refer to <a href="#">4.3.2 Menu Set 1-Beam masking</a>.</p>
	<p>It is not possible to enter a negative grade value.</p>	<p>The Rugby has been configured to only allow the entry of positive grade values. This can be disabled on the grade entry menu screen.</p>

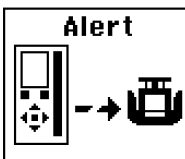
Alert	Symptom	Possible causes and solutions				
	<p>The Rugby is not communicating with the Combo+.</p>	<p>The Rugby has lost the communication link to the remote control.</p> <p>☞ Ensure that you are within clear sight of the Rugby and that you have not exceeded the 100 m (300') working range.</p>				
	<p>Smart Target features do not work.</p>	<p>The Smart Target feature could not be completed.</p> <p>☞ Ensure that you are working on the correct axis and that you have not exceeded the 100 m (300') working range.</p>				
	<p>Axis Alignment does not work.</p>	<p>The Axis Alignment procedure could not be completed.</p> <p>☞ Ensure that you are working on the correct axis and that you have not exceeded the 100 m (300') working range.</p>				
 <table border="1" data-bbox="523 1583 708 1654"> <tr> <td>X+: 0</td> <td>X-: 0</td> </tr> <tr> <td>Y+: 0</td> <td>Y-: 0</td> </tr> </table>	X+: 0	X-: 0	Y+: 0	Y-: 0	<p>Semi-automatic Calibration does not work.</p>	<p>The Semi-automatic Calibration procedure could not be completed.</p> <p>☞ Repeat the procedure. If the procedure is still not successful, contact an authorised service centre.</p>
X+: 0	X-: 0					
Y+: 0	Y-: 0					

Alert	Symptom	Possible causes and solutions
	<p>A calibration reminder has been set for the device.</p>	<p>To stop the alert from appearing, either disable/update it, or send the Rugby to be calibrated. Refer to <a href="#">4.3.3 Menu Set 2- Calibration alert function</a>.</p>
	<p>The firmware on the Combo+ and the Rugby are not compatible.</p>	<p>This may only cause minor issues, but to ensure the Rugby and Combo+ perform optimally, contact an authorised service centre.</p>
	<p>An internal hardware failure has occurred within the Rugby.</p>	<p>There is a serious fault with the Rugby. Contact an authorised service centre.</p>
	<p>The battery power within the Combo+ is very low.</p>	<p>Charge the Combo+.</p>

## Troubleshooting

Problem	Possible causes	Suggested solutions
The Rugby does not turn on.	The batteries are low or dead.	Check the batteries and change or charge the batteries if necessary. If the problem continues, return the Rugby to an authorised service centre for service.
The distance of the Rugby is reduced.	Dirt is reducing the laser output.	Clean the windows of the Rugby and the Combo+. If the problem continues, return the Rugby to an authorised service centre for service.
The Combo+ is not working properly.	The Rugby is not rotating. It may be self-levelling or in H.I.Alert.	Check for proper operation of the Rugby.
	The Combo+ is out of usable range.	Move closer to the Rugby. For normal operation, the Combo+ works up to 300 m (1,000').
	The batteries of the Combo+ are low.	Check the low battery symbol on the Combo+ display. Change the batteries.
The display is too dark or too light.	The setting of the display contrast is unsuitable.	The contrast for the Combo+ can be reset in the menu. Refer to <a href="#">4.3.3 Menu Set 2-Screen contrast</a> .
The grade is shown in percent (%) or per mil (‰).	The wrong setting has been selected.	The Rugby laser has been configured to show percent (%) or per mil (‰) grade values. This can be changed on the grade entry menu screen. Refer to <a href="#">4.3.4 Grade Entry-Display - Percent/Per Mil</a> .
The grade resets to zero each time the laser is turned on.	The wrong setting has been selected.	The Rugby laser has been configured to reset grade values when turned off or put to sleep. This can be changed on the grade entry menu screen. Refer to <a href="#">Save grade</a> .
The laser stops too often to re-level.	The sensitivity setting may be set to the "fine" setting (Setting 1).	The vibration/wind sensitivity can be modified in the menu. Refer to <a href="#">4.3.2 Menu Set 1-Sensitivity</a> .
	The Tripod may be unstable.	Check your tripod for stability. Tighten all screws. Use sand bags on the legs if necessary.

Problem	Possible causes	Suggested solutions
	The wind is causing the Rugby to move too much.	Shelter the Rugby from the wind. Press the tripod legs more firmly into the ground.
The screen of the Combo+ freezes or behaves unusually.	Software malfunction or strong interference from external power sources.	Try to power the Combo+ off and on again. If this does not resolve the issue, press the Power/ESC button of the Combo+ for 10 seconds.
Unable to enter a grade value above a certain number.	The laser model variant installed on the Rugby has limited grade capabilities. It is not possible to enter grade values greater than 10% in one axis, when the other axis has a value greater than 3%.	Depending on the model variant, the Rugby allows for up to 10% grade entry in both axes simultaneously. If the grade entry for one axis is greater than 10%, the cross axis is limited to 3%
The Combo+ digital read out is disappearing and reappearing, even with a steady beam.	At greater distances, a faster head speed is required for the beam to be detected optimally.	The head speed can be modified in the menu. Refer to <a href="#">4.3.2 Menu Set 1-Head speed</a> .

## 11 Care and Transport

---

### 11.1 Transport

---

<b>Transport in the field</b>	<p>When transporting the equipment in the field, always make sure that you</p> <ul style="list-style-type: none"><li>• either carry the product in its original container,</li><li>• or carry the tripod with its legs splayed across your shoulder, keeping the attached product upright.</li></ul>
<b>Transport in a road vehicle</b>	<p>Never carry the product loose in a road vehicle, as it can be affected by shock and vibration. Always carry the product in its container and secure it.</p>
<b>Products without container</b>	<p>For products for which no container is available use the original packaging or its equivalent.</p>
<b>Shipping</b>	<p>When transporting the product by rail, air or sea, always use the complete original Leica Geosystems packaging, container and cardboard box, or its equivalent, to protect against shock and vibration.</p>
<b>Shipping, transport of batteries</b>	<p>When transporting or shipping batteries, the person responsible for the product must ensure that the applicable national and international rules and regulations are observed. Before transportation or shipping, contact your local passenger or freight transport company.</p>
<b>Field adjustment</b>	<p>Exposing the product to high mechanical forces, for example through frequent transport or rough handling, or storing the product for a long time may cause deviations and a decrease in the measurement accuracy. Periodically carry out test measurements and perform the field adjustments indicated in the User Manual before using the product.</p>

---

### 11.2 Storage

---

<b>Product</b>	<p>Respect the temperature limits when storing the equipment, particularly in summer if the equipment is inside a vehicle. Refer to <a href="#">12 Technical Data</a> for information about temperature limits.</p>
<b>Li-Ion batteries</b>	<ul style="list-style-type: none"><li>• Remove batteries from the product and the charger before storing.</li><li>• After storage recharge batteries before using.</li><li>• Protect batteries from damp and wetness. Wet or damp batteries must be dried before storing or use.</li><li>• A storage temperature range of 0 °C to +30 °C / +32 °F to +86 °F in a dry environment is recommended to minimize self-discharging of the battery</li><li>• At the recommended storage temperature range, batteries containing a 40% to 50% charge can be stored for up to one year. After this storage period the batteries must be recharged</li></ul>

---

### 11.3 Cleaning and Drying

---

<b>Product and accessories</b>	<ul style="list-style-type: none"><li>• Blow dust off lenses and prisms.</li><li>• Never touch the glass with your fingers.</li></ul>
--------------------------------	---

- Use only a clean, soft, lint-free cloth for cleaning. If necessary, moisten the cloth with water or pure alcohol. Do not use other liquids; these may attack the polymer components.

---

### Damp products

Dry the product, the transport container, the foam inserts and the accessories at a temperature not greater than 40 °C /104 °F and clean them. Remove the battery cover and dry the battery compartment. Do not repack until everything is completely dry. Always close the transport container when using in the field.

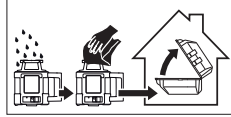

---

### Cables and plugs

Keep plugs clean and dry. Blow away any dirt lodged in the plugs of the connecting cables.

---



This equipment has been tested and found to comply with the limits for a Class B digital device, pursuant to part 15 of the FCC Rules.

These limits are designed to provide reasonable protection against harmful interference in a residential installation.

This equipment generates, uses, and can radiate radio frequency energy and, if not installed and used in accordance with the instructions, it may cause harmful interference to radio communications.

However, there is no guarantee that interference does not occur in a particular installation.

If this equipment does cause harmful interference to radio or television reception, which can be determined by turning the equipment off and on, the user is encouraged to try to correct the interference by one or more of the following measures:

- Reorient or relocate the receiving antenna.
- Increase the separation between the equipment and the receiver.
- Connect the equipment into an outlet on a circuit different from that to which the receiver is connected.
- Consult the dealer or an experienced radio/TV technician for help.

---

Responsible Party – U.S. Contact Information

Michael Harvey  
Leica Geosystems, Inc.  
10035 Via Colomba Cir #205  
Fort Myers, FL 33966, USA  
Tel.: (615) 585-0689  
Email: michael.harvey@leicaus.com

**Canada**

---

CAN ICES-003(B)/NMB-003(B)  
Contains IC: 3177A-CT301

---

**Canada Compliance Statement**

This device contains licence-exempt transmitter(s)/receiver(s) that comply with Innovation, Science and Economic Development Canada's licence-exempt RSS(s). Operation is subject to the following two conditions:

1. This device may not cause interference
2. This device must accept any interference, including interference that may cause undesired operation of the device

**Canada Déclaration de Conformité**

L'émetteur/récepteur exempt de licence contenu dans le présent appareil est conforme aux CNR d'Innovation, Sciences et Développement économique Canada applicables aux appareils radio exempts de licence. L'exploitation est autorisée aux deux conditions suivantes:

1. L'appareil ne doit pas produire de brouillage
2. L'appareil doit accepter tout brouillage radioélectrique subi, même si le brouillage est susceptible d'en compromettre le fonctionnement du dispositif

---

**Radio Frequency (RF) Exposure Compliance Statement**

The radiated RF output power of the instrument is below the Health Canada's Safety Code 6 exclusion limit for portable devices (radiated element separation

distance between the radiating element and user and/or bystander is below 20 cm).

## Japan

- This device is granted pursuant to the Japanese Radio Law (電波法).
- This device should not be modified (otherwise the granted designation number will become invalid).

## Others

The conformity for countries with other national regulations has to be approved prior to use and operation.

## 12.1.2

### Products without Radio

#### Labelling Rod Eye receivers

- a Rod Eye 120
- b Rod Eye 140
- c Rod Eye 160

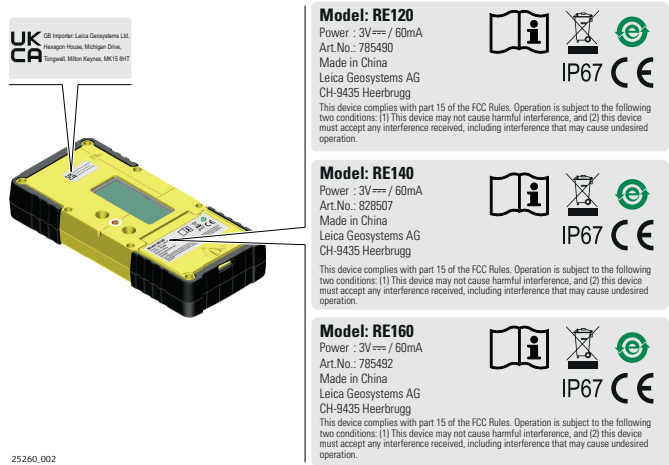

## EU



Hereby, Leica Geosystems AG declares that the product/s is/are in compliance with the essential requirements and other relevant provisions of the applicable European Directives.

The full text of the EU declaration of conformity is available at the following Internet address:

<http://www.leica-geosystems.com/ce>.

### CAUTION

This equipment is not intended for use in residential environments and may not provide adequate protection to radio reception in such environments.

## USA

FCC Part 15, Part 15 B

This device complies with part 15 of the FCC Rules. Operation is subject to the following two conditions:

1. This device may not cause harmful interference, and
2. This device must accept any interference received, including interference that may cause undesired operation.

This equipment has been tested and found to comply with the limits for a Class B digital device, pursuant to part 15 of the FCC Rules.

These limits are designed to provide reasonable protection against harmful interference in a residential installation.

This equipment generates, uses, and can radiate radio frequency energy and, if not installed and used in accordance with the instructions, it may cause harmful interference to radio communications.

However, there is no guarantee that interference does not occur in a particular installation.

If this equipment does cause harmful interference to radio or television reception, which can be determined by turning the equipment off and on, the user is encouraged to try to correct the interference by one or more of the following measures:

- Reorient or relocate the receiving antenna.
- Increase the separation between the equipment and the receiver.
- Connect the equipment into an outlet on a circuit different from that to which the receiver is connected.
- Consult the dealer or an experienced radio/TV technician for help.

---

Responsible Party – U.S. Contact Information  
 Michael Harvey  
 Leica Geosystems, Inc.  
 10035 Via Colomba Cir #205  
 Fort Myers, FL 33966, USA  
 Tel.: (615) 585-0689  
 Email: michael.harvey@leicaus.com

**Canada**

CAN ICES-003(B)/NMB-003(B)

**Others**

The conformity for countries with other national regulations has to be approved prior to use and operation.

**12.2**

**General Technical Data of the Product**

**Operating range**

**Rugby CLAx Operating range (diameter):**

With Rod Eye 160/Combo+      1,350 m/(4,430 ft)

**Self-levelling accuracy**

Type	Value
------	-------

Self-levelling accuracy <sup>2)</sup>	±1.5 mm at 30 m (±1/16" at 100 ft)
---------------------------------------	------------------------------------

**Self-levelling range**

Type	Value
------	-------

Self-levelling range	±6°
----------------------	-----

**Head speed**

Type	Value
------	-------

Head speed	0, 2, 5, 10, 15 rps
------------	---------------------

<sup>2)</sup> Self-levelling accuracy is defined at 25 °C (77 °F).

## Dimensions

### Rugby



### Combo+

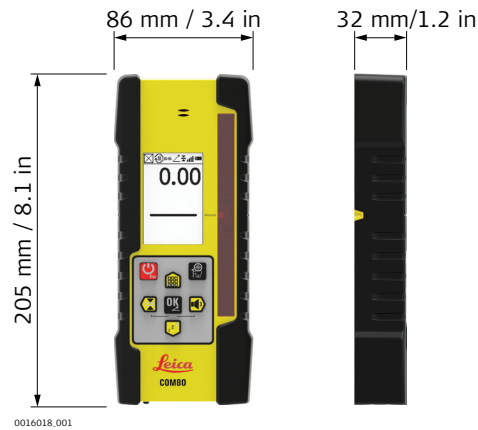

## Weight

Type	Value
Rugby weight with battery	3.8 kg/8.4 lbs.
Rugby weight without battery	3.4 kg/7.5 lbs.
Combo+	0.4 kg/0.9 lbs

## Internal battery for Rugby and Combo+

Type	Operating times* at 20°C
Lithium-Ion (Li-Ion Pack)	50 h

\*Operating times are dependent upon environmental conditions.

☞ Charging the Li-Ion battery pack takes a maximum of five hours.

## Environmental specifications for Rugby and Combo+

### Temperature

Operating temperature	Storage temperature
-20 °C to +50 °C (-4 °F to +122 °F)	-40 °C to +70 °C (-40 °F to +158 °F)

### Protection against water, dust and sand

Protection
Rugby: IP68 (IEC 60529) / MIL-STD-810G w/CHANGE 1 512.6 procedure I

**Protection**

Combo+: IP67 (IEC 60529) / MIL-STD-810G w/CHANGE 1 512.6 procedure I

Dust tight

Protected against continuous immersion in water.

**A100 Lithium-Ion charger**

Type	Value
Type	Li-Ion battery charger
Input voltage	100 V AC-240 V AC, 50 Hz-60 Hz
Output voltage	12 V DC
Output current	3.0 A
Polarity	Shaft: negative, Tip: positive

**CLB Lithium-Ion battery pack**

Type	Value
Type	Li-Ion battery pack
Input voltage	12 V DC
Input current	2.5 A
Charge time	5 hours (maximum) at 20 °C

## 13

## Lifetime Manufacturer's Warranty

---

### 13.1

### Rugby

---

#### Description



#### Lifetime<sup>3)</sup> Manufacturers Warranty

Warranty coverage for the entire usage time of the product under PROTECT according to Leica Geosystems International Limited Warranty and PROTECT General Terms & Conditions set out under [Leica Warranty](#). Free charge repair or replacement of all products or any parts under PROTECT that suffer defects as a result of faults in materials or manufacturing.

#### 5 Years No Costs

Additional services should the product under PROTECT become defective and require servicing under normal conditions of use, as described in the User Manual, at no additional charge.

---

#### Description

#### Two Year Knockdown Warranty

In addition to the lifetime manufacturer's warranty and the "No Cost" period for additional services, the internal self-levelling system of the product under PROTECT is covered. Should any accident or knockdown occur within two years of the purchase date, all repairs to the internal self-levelling assembly will be covered under PROTECT General Terms & Conditions.

---

### 13.2

### Combo+

---

#### Description



#### Lifetime<sup>3)</sup> Manufacturers Warranty

Warranty coverage for the entire usage time of the product under PROTECT according to Leica Geosystems International Limited Warranty and PROTECT General Terms & Conditions set out under [Leica Warranty](#). Free charge repair or replacement of all products or any parts under PROTECT that suffer defects as a result of faults in materials or manufacturing.

#### 3 Years No Costs

Additional services should the product under PROTECT become defective and require servicing under normal conditions of use, as described in the User Manual, at no additional charge.

---

<sup>3)</sup> Lifetime - Product lifetime

Accessories for the power supply



16024.002

**A100 - Li-Ion Charger (790417)**

The A100 Li-Ion charger comes complete with four separate AC adaptors.



25261.001

**A130 - 12 Volt Battery Cable (790418)**

The A130 12 volt battery cable connects the Rugby to a standard 12 volt automotive battery as a backup for the battery of the unit. Length: 4 metres/13 feet.



25262.001

**A140 - Car Adapter Cable (797750)**

The A140 car adapter cable connects the Rugby to a standard automotive accessory jack as a backup for the battery of the unit or to charge in a vehicle. Length: 2 metres/6.5 feet.



25265.001

**Smart Adapter (864855)**

The Smart Adapter combines the features of a wall mount bracket and a batter-board clamp. It also comes with a 90 ° Combo+ batter-board clamp.



25263.001

### **CLB - Li-Ion Battery Pack (855974)**

The CLB Li-Ion battery pack is included as part of the standard rechargeable package. To complete the Li-Ion battery solution, it is also necessary to purchase the A100, Li-Ion battery charger.



25264.001

### **Rugby - Scope and Plate (864859)**

The A260 Scope and Mount attaches magnetically to the top of the Rugby CLAx and provides a repeatable solution for axis alignment and second day setups. The scope must be initially aligned to individual units.



**1007268-1.1.0en**

Original text (1007268-1.1.0en)

Published in Switzerland, © 2025 Leica Geosystems AG



- when it has to be **right**



**Leica Geosystems AG**

Heinrich-Wild-Strasse  
9435 Heerbrugg  
Switzerland

[www.leica-geosystems.com](http://www.leica-geosystems.com)

